

# W&E SALES CO., INC.

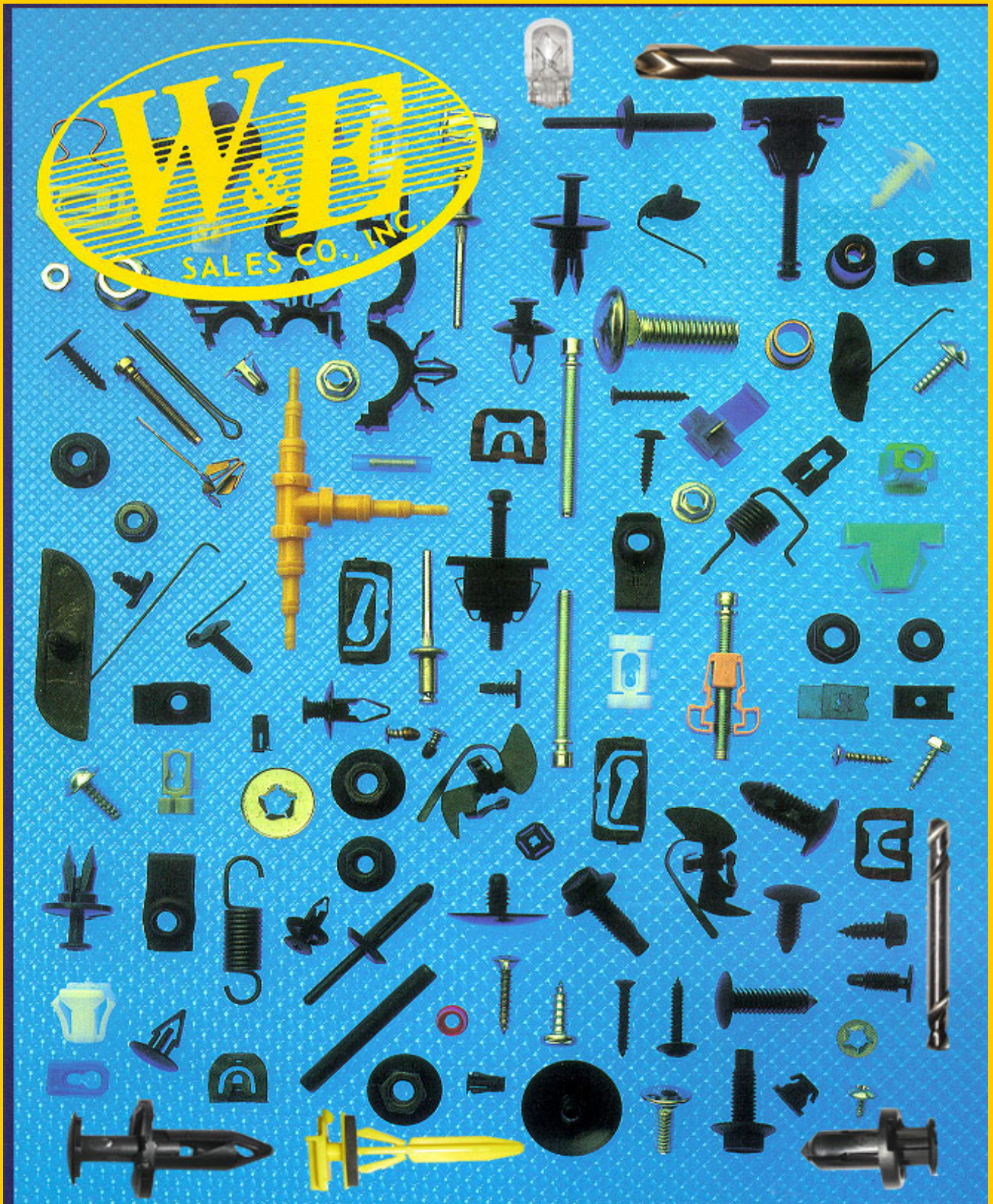

THE COMPLETE LINE OF HARDWARE & SPECIALIZED TOOLS

FOR THE AUTOBODY & AUTO GLASS SHOP

2013-2014



# THE WEE PAK LINE

## W&E SALES COMPANY'S SMALL PACKAGE LINE

### WEE PAK RAK #1 (ORIGINAL WEE PAK RAK)

INCLUDES 144 MASTER PACKS  
(576 TOTAL WEE PAKS, REVOLVING  
DISPLAY RACK, 144 HOOKS, HEADER  
CARD AND 5 WALL CHARTS)

PART LISTING FOR WEE PAK RAK #1  
SEE PAGE 182

### WEE PAK RAK #2

INCLUDES ADDITIONAL  
144 MASTER PACKS  
(576 TOTAL WEE PAKS, REVOLVING  
DISPLAY RACK, 144 HOOKS, HEADER  
CARD AND 5 WALL CHARTS)

PART LISTING FOR WEE PAK RAK #2  
SEE PAGE 183



# W & E SALES CO., INC.

NEWARK, NEW JERSEY

## CONTENTS

<u>Product</u>	<u>Page number</u>
Acid Brushes.....	140
Assortments.....	143-164
Bin Labels.....	186
Body Bolts- Metric.....	87-90
Body Bolts- USS.....	90
Bolts-USS.....	132-133
Bolts-Metric.....	132
Bulbs: Automotive miniature.....	124-128
Bulbs: Halogen.....	127
Bulb sockets, pigtail connectors.....	129-130
Bumper Bolts.....	92
Bumper Bolt Retainers.....	92
Bumper Retainers-Plastic.....	20-21, 25-27, 37-40, 46-60
Bushings-Door Hinge.....	109
Cabinets-racks, storage, bins.....	168-169
Cable straps.....	118
Can clips.....	140
Clip nuts.....	84-85
Clamp bracket-(body and frame straightening).....	138
Clips- "E", push on.....	93
Clip Removal Tool.....	141
Clips-speed.....	84-85
Clips-tubular.....	105
Cotter Pins.....	115
Cowl/ Grille retainers.....	19-20, 27, 40, 47, 49, 51-54,56, 59-60
Display Case, Prints.....	187
Door glass window regulator rivets.....	66-67
Door handle clip removal tool.....	140
Door hinge pins, door hinge bushings.....	109-114
Door lock clips.....	62
Door trim clips.....	34-45
Drills-body panel.....	134
Drills-high speed twist.....	135
Electric connectors-solderless terminals insulated.....	119-121
Expansion test plugs.....	142
Exterior panel fasteners, plastic retainers.....	15-60
Fax Order Form.....	185
Fender retainers.....	25-27, 39-40, 49-51, 53-56, 58-61
Fender washers.....	133

BOOK NO. 7/13

CONTENTS



<b>Product</b>	<b>Page number</b>
Fender welt.....	142
Finishing sems screws.....	80-81
Finishing washers.....	115
Flange Nuts.....	91
Flat Washers.....	133
Foldover nuts-Metric.....	86
Foldover nuts-USS.....	85
Free spinning washer nuts.....	91
Fuses- ATO/ATC, Mini, AGC/Glass, Low profile.....	123
Glass Guides.....	65
Grille retainers.....	19-20, 27, 40, 47, 49, 51-54, 56, 59-60
Grommets-plastic.....	99-104
Handle parts.....	65
Headlamp adjusting assemblies, nuts, screws.....	95-98
Headlamp adjusting springs.....	95
Heat shrink terminals.....	122
Heat shrinkable tubing.....	121
Hex head body bolts.....	87-90
Hinge pins (door).....	110-114
Hinge pin bushings (door).....	109
Hog rings.....	60
Hog ring pliers.....	136
Hole plugs.....	117
Hood, hood seal clips.....	31-34,61
Hose clamps.....	136
Inserts, threaded.....	105, 165
License plate bolts & nuts.....	106-107
Machine screws.....	115
Machine screw nuts.....	93
Metric body bolts.....	87-90
Metric conversion table.....	21,139,141,160
Metric foldover nuts-speed nuts-USS-SAE.....	85-86
Moulding bolts, clips, fasteners.....	13-18
Moulding release tool.....	139
Mounting hardware.....	107-108
Nuts-hex machine.....	93
Nuts-Locking.....	92
Nuts-Metric.....	91
Nuts-plastic.....	99-104
Nuts-USS.....	132-133
OEM number to W&E number cross reference guide.....	172-181
Parts boxes.....	168-169
Piano wire.....	137
Pins-Door Hinge and Door Hinge pin/bushing sets.....	109-114
Plastic cable straps.....	118

**CONTENTS**





<b>Product</b>	<b>Page number</b>
Plastic razor blades.....	139
Plastic rivets .....	72
Plastic storage boxes.....	169
Pull rods; pull rod set.....	138
Push type rivets.....	45-55
Razor blades.....	142
Retainers-headlamp.....	95-98
Retainers-hood.....	31-34, 61
Retainers-push type.....	45-56
Retainers-screw type.....	56-60
Retainers-trim.....	34-45
Retainers-Weatherstrip.....	28-31
Rivets-plastic.....	72
Rivets-special.....	60-70
Rivets-standard.....	71
Rivet tool.....	138
Rivet tool (for plastic rivets).....	152
Sales Aids.....	186-187
Screws-black.....	73-78, 82
Screws-bright.....	79-83
Screws-loose washer.....	73-76,80-81
Screws-specialized.....	83
Screw Rivets.....	56-60
Screws-tek type.....	78,81
Shims.....	131
Software (fastener invoicing).....	170
Special plastic parts.....	116-117
Specialized sheet metal screws.....	83
Spot Weld Drills.....	134
Squeegees (rubber).....	140
Stud caps.....	93
Stud retainers.....	93
Tape-double sided.....	140
Thread cutting nuts.....	94
Tools and specialties.....	136-142, 165
Toothed lock washers; machine screws.....	115
Trim pad removal tool.....	139
Tubular clips.....	105
Wall Charts.....	186
Washers Finishing.....	115
Washers-flat, lock, metric, SAE.....	133
Weatherstrip clips.....	28-31
Weatherstrip-door and trunk.....	137
Wee Pak Raks.....	Inside Front Cover
Wee Pak Rak #1 parts listing.....	182

**CONTENTS**

<b>Product</b>	<b>Page number</b>
Wee Pak Rak #2 parts listing.....	183
"We Trak" Fastener Invoicing Software.....	170
Window Riser Knobs.....	65
Windshield and rear window moulding clips.....	63-64
Windshield removal tools.....	137
Wire Harness clips.....	116
Wire loom.....	123
Wire-piano.....	137
Wire-electrical.....	142
Wire-windshield.....	137





Part #	Page	Part #	Page	Part #	Page	Part #	Page	Part #	Page	Part #	Page
1/16 Drill	135	387	63	638	79	815	99	975	131	2105	41
1/2 Drill	135	389	64	639	79	817	99	985	71	2107	36
1/4 Drill	135	390	64	641	79	818	99,107	986	71	2108	36
1/8 Drill	135	421	119	643	79	819	99	988	118	2109	22
3/16 Drill	135	424	119	646	79	822	99	989	118	2116	96
3/32 Drill	135	425	119	654	79	825	99	990	118	2117	41
3/8 Drill	135	426	119	655	79	826	99,107	991	118	2118	96
4LR	168	427	119	656	79	829	95	999	60	2119	96
5/16 Drill	135	428	119	657	79	830	95	1010	96	2120	118
5/32 Drill	135	429	119	658	79	832	98	1011	96	2121	66
5/64 Drill	135	430	119	659	79	835	97	1012	96	2122	66
7/16 Drill	135	432	119	660	79	836	95	1013	96	2123	66
7/32 Drill	135	433	119	663	79	837	97	1024	95	2124	97
7/64 Drill	135	434	119	667	79	839	97	1025	96	2126	118
9/32 Drill	135	437	119	670	79	840	95	1034	96	2127	14
9/64 Drill	135	440	119	671	83	842	95	1036	115	2129	116
11/32 Drill	135	441	119	672	64,83	844	98	1037	115	2130	71
11/64 Drill	135	442	119	673	78	846	84	1038	115	2131	71
13/32 Drill	135	443	119	674	78	852	84	1039	115	2132	71
13/64 Drill	135	444	119	675	78	853	84	1040	97	2133	71
15/32 Drill	135	445	119	676	78	855	84	1041	97	2134	71
15/64 Drill	135	446	119	680	79	858	84	1042	115	2135	71
17	137	448	119	682	79	859	84	1044	115	2136	71
17/64 Drill	135	449	119	683	79	860	84	1050	92	2137	71
18	137	450	120	684	79	861	84	1051	92	2138	71
18D	168	451	121	685	79	874	105	1052	92	2139	71
19	137	452	121	686	79	875	105	1061	115	2140	36
19/64 Drill	135	453	121	687	79	878	105	1062	115	2142	14
21/64 Drill	135	454	120	689	79	879	105	1063	115	2143	95
23/64 Drill	135	455	119	728	92	885	93	1064	115	2144	96
25/64 Drill	135	501	79	729	92	886	93	1065	115	2146	116
27/64 Drill	135	505	79	730	92	887	93	1071	115	2147	117
29/64 Drill	135	509	79	731	92	888	93	1072	115	2148	78
30	137	537	79,106	732	92	889	93	1073	115	2149	78
30D	169	575	82	733	92	890	93	1074	115	2150	81
31	137	579	82	740	92	910	85	1075	115	2154	105,165
31/64 Drill	135	580	82	741	92	911	85	1077	115	2155	105,165
36B	168	582	82	760	92	915	85	1078	115	2156	105,165
146	13	586	82	761	92	916	85	1079	115	2158	115
147	13	587	82	762	92	917	85	1205	41	2159	115
150	13	588	82	763	92	920	94	1206	28	2160	115
156	13	590	82	764	92	921	94	1210	60	2161	108
161	13	593	82	765	92	922	94	1212	60	2162	71
175	13	596	82	766	92	923	94	1213	60	2163	14
332	13	597	82	767	92	929	93	1220	60	2164	84
333	13	598	82	775	93	940	90	1222	32	2165	15
336	13	599	82	776	93	942	90	1223	32	2167	115
341	14	601	82	777	13,93	943	90	1224	32	2168	115
345	14	602	82	778	93	944	90	1225	36	2169	115
349	14	603	82	779	93	945	90	1250	14,71	2170	115
350	14	605	82	780	93	951	133	1262	65	2171	115
351	14	620	79	786	93	952	133	1290	62	2172	115
352	14	621	79	787	93	953	133	1411	115	2173	99
353	63	622	79	788	93	957	133	1415	115	2175	18
354	63	625	83	789	93	963	107	1420	115	2176	64
355	63	627	79	793	93	965	131	1651	80	2178	95
371	63	628	79	797	91	966	131	1652	80	2179	95
373	63	629	79	798	91	969	131	1653	80	2183	108
378	63	631	79	799	91	970	131	1659	80	2184	80
379	63	633	79	800	91	971	131	1725	148	2185	80
384	63	635	79	810	116	972	131	2101	99	2186	80
385	63	636	79	811	84	973	131	2102	118	2187	80
386	63	637	79	814	84	974	131	2104	47	2189	80



Part #	Page	Part #	Page	Part #	Page	Part #	Page	Part #	Page	Part #	Page
2190	41	2277	100	2359	110	2425	32	2495	25	2561	35
2193	73	2278	35	2360	110	2426	117	2496	25	2562	94
2194	71	2279	37	2361	56	2427	117	2497	118	2563	66
2195	18	2280	64	2363	35	2428	117	2498	80	2564	136
2196	18	2281	109	2364	35	2430	117	2499	80	2565	136
2197	14	2282	109	2365	37	2431	117	2500	80	2566	136
2199	41	2283	109	2366	56	2432	108	2501	80	2567	136
2200	60	2284	109	2367	37	2433	108	2502	101	2568	136
2203	82,106	2285	108	2368	18	2434	133	2503	101	2569	136
2204	36	2286	41	2369	18	2435	133	2504	35	2570	136
2207	28	2287	73	2370	17	2436	133	2505	62	2571	136
2208	99	2289	116	2371	64	2437	47	2506	62	2572	93
2210	99	2290	116	2372	20	2438	47	2507	62	2573	93
2211	98	2291	41	2373	35	2439	72	2508	62	2574	93
2212	98	2293	16	2374	100	2440	61	2509	62	2575	77
2213	99	2296	78	2375	41	2441	61	2510	62	2576	120
2214	100	2297	78	2376	64	2442	61	2511	42	2577	120
2216	46	2298	64	2378	17	2443	61	2512	38	2578	18
2219	116	2299	37	2379	28	2444	106	2513	80	2579	65
2220	85	2300	18	2381	100	2445	100	2514	73	2580	98
2221	15	2301	15	2382	83	2446	106	2515	115	2581	101
2222	83	2303	15	2383	95	2447	83	2518	115	2582	25
2223	46	2304	105	2384	20	2448	131	2519	82	2583	32
2224	41	2305	100	2385	118	2449	131	2520	82	2584	76
2225	76	2306	15	2386	118	2450	83	2521	71	2585	77
2226	76	2308	15	2387	61	2452	66	2522	108	2586	77
2227	77	2310	15	2388	46	2453	47	2523	31	2588	71
2229	15	2311	15	2389	79	2454	79	2524	108	2589	71
2230	32	2315	16	2390	79	2455	35	2525	107	2590	71
2231	92	2317	16	2391	79	2456	97	2526	108	2591	82
2232	15	2319	78	2392	79	2457	109	2527	107	2592	57
2233	15	2320	78	2393	79	2458	47	2528	78	2593	133
2235	97	2321	67	2394	79	2459	37	2529	78	2594	133
2236	100	2322	73	2395	79	2460	56	2530	133	2595	121
2237	56	2324	108	2396	79	2461	38	2531	133	2596	121
2240	80	2325	77	2397	79	2462	42	2532	133	2597	79
2244	100	2326	106	2398	46	2463	81	2533	133	2598	19
2245	105	2327	109	2399	46	2464	93	2534	98	2599	48
2246	41	2328	73	2400	105	2465	93	2535	97	2600	112
2247	100	2329	73	2401	78	2466	93	2536	71	2601	133
2248	98	2330	67	2402	13	2467	93	2537	71	2602	133
2249	65	2331	78	2403	83	2468	93	2538	62	2603	133
2250	65	2332	78	2404	83	2469	93	2539	101	2604	133
2251	65	2333	78	2405	56	2470	71	2540	123	2605	133
2254	15	2334	78	2406	100	2471	71	2541	123	2607	61
2255	85	2335	78	2407	37	2472	71	2542	123	2608	18
2256	73	2336	15	2408	17	2473	100	2543	123	2609	57
2257	28	2338	98	2409	81	2475	57	2544	123	2610	98
2259	83	2339	100	2410	79	2477	57	2545	123	2611	98
2260	79	2340	78	2411	79	2478	47	2546	116	2612	48
2263	71	2341	83	2412	79	2479	101	2547	106	2613	57
2264	72	2342	73	2413	46	2480	68	2548	57	2614	48
2265	72	2343	78	2414	28	2482	81	2549	57	2615	48
2266	72	2344	78	2415	56	2484	81	2550	47	2617	48
2267	72	2345	77	2416	42	2485	72	2551	47	2618	28
2268	97	2346	84	2417	42	2486	81	2552	42	2619	57
2269	118	2347	37	2418	37	2488	82	2553	123	2620	81
2270	72	2353	67	2419	16	2489	73	2554	123	2621	42
2271	82	2354	67	2420	47	2490	42	2555	123	2622	66
2272	108	2355	72	2421	14,16	2491	57	2556	123	2623	77
2273	62	2356	37	2422	116	2492	35	2557	76	2624	57
2274	41	2357	110	2423	73	2493	32	2558	76	2625	62
2275	81	2358	110	2424	78	2494	101	2560	61	2627	57





Part #	Page	Part #	Page	Part #	Page	Part #	Page	Part #	Page	Part #	Page
2628	28	2697	123	2770	118	2836	107	2902	49	2967	33
2629	38	2698	123	2771	118	2837	108	2903	105,165	2968	20
2630	68	2699	48	2772	107	2838	78	2904	105,165	2969	102
2632	16	2700	98	2773	107	2839	78	2905	78	2970	102
2633	16	2701	48	2774	66	2840	77	2906	108	2971	31
2634	74	2702	117	2775	67	2841	77	2907	108	2972	33
2635	110	2703	64	2776	67	2842	80	2908	64	2973	33
2637	109	2704	106	2777	76	2843	80	2909	123	2974	50
2638	111	2705	42	2778	76	2844	28	2910	25	2975	65
2639	109	2706	35	2779	106	2845	28	2911	25	2976	39
2640	72	2707	42	2780	17	2846	129	2912	50	2977	59
2641	72	2708	85	2781	79	2847	129	2913	33	2978	44
2642	72	2714	110	2782	74	2848	29	2914	123	2979	65
2643	38	2715	78	2783	82	2849	43	2915	123	2980	94
2644	38	2716	58	2784	17	2850	101	2916	123	2981	75
2645	93	2717	48	2785	35	2851	43	2917	123	2982	105
2646	93	2718	58	2786	17	2852	68	2918	123	2983	33
2647	93	2719	58	2787	77	2853	74	2919	27	2984	102
2648	93	2720	101	2788	77	2854	116	2920	74	2985	50
2649	19	2721	42	2790	94	2855	116	2921	77	2986	50
2650	19	2722	117	2791	93	2856	71	2922	77	2987	51
2651	18	2723	117	2792	71	2857	71	2923	29	2988	117
2652	28	2724	117	2793	115	2858	68	2924	29	2989	117
2653	72	2725	117	2794	43	2859	76	2925	29	2990	29
2655	57	2726	42	2795	43	2860	83	2926	85	2991	51
2656	32	2727	43	2796	81	2861	38	2927	33	2992	39
2657	81	2728	66	2797	81	2862	123	2928	71	2993	34
2658	81	2729	48	2798	81	2863	38	2929	71	2994	113
2659	81	2730	74	2800	74	2864	43	2931	50	2995	114
2660	81	2733	81	2801	33	2865	118	2932	50	2996	81
2661	107	2734	81	2802	79	2866	102	2933	29	2997	81
2662	107	2735	81	2803	82	2868	123	2934	129	2998	81
2663	106	2736	81	2804	78	2869	123	2935	19	2999	81
2665	77	2738	81	2805	78	2870	123	2936	19	3000	81
2667	121	2739	49	2806	117	2871	123	2937	19	3001	81
2668	121	2740	109	2807	117	2872	123	2938	65	3002	65
2669	121	2741	109	2808	123	2873	123	2939	43	3003	65
2670	121	2742	78	2809	27	2874	123	2940	74	3004	44
2671	121	2743	78	2810	108	2875	123	2941	62	3005	39
2672	121	2744	80	2811	122	2876	123	2942	59	3006	39
2673	121	2745	80	2812	122	2877	123	2943	111	3007	39
2674	121	2746	74,80	2813	122	2878	123	2944	111	3008	39
2675	16	2747	90	2814	122	2879	105	2945	27	3009	39
2676	61	2748	114	2815	122	2881	76	2946	27	3010	36
2677	35	2749	68	2816	122	2882	58	2947	102	3011	29
2678	33	2750	68	2817	122	2883	49	2948	43	3012	62
2679	27	2751	85	2818	122	2884	58	2949	113	3013	59
2680	38	2752	33	2819	122	2885	49	2950	113	3014	29
2681	101	2753	112	2820	122	2886	49	2951	62	3015	75,81
2682	58	2754	136	2821	122	2887	49	2952	38	3016	75,81
2683	101	2755	22	2822	122	2888	68,95	2953	50	3017	44
2684	74	2756	101	2823	122	2889	49	2954	65	3018	51
2685	78	2757	49	2824	122	2890	67	2955	65	3019	51
2686	58	2758	58	2825	122	2891	67	2956	62	3020	102
2687	31	2759	28	2826	122	2892	17	2957	33	3021	102
2688	68,71	2760	35	2827	122	2893	43	2958	50	3022	102
2689	123	2762	78	2828	122	2894	25	2959	50	3023	51
2690	123	2763	80	2829	122	2895	106	2960	17	3024	59
2691	123	2764	81	2830	122	2896	111	2961	31	3025	102
2692	123	2765	81	2831	122	2897	58	2962	43	3026	102
2693	123	2766	28	2832	122	2898	49	2963	102	3027	67
2694	123	2767	61	2833	122	2899	43	2964	31	3029	129
2695	123	2768	101	2834	122	2900	38	2965	102	3030	129
2696	123	2769	16	2835	122	2901	113	2966	31	3031	129



Part #	Page	Part #	Page	Part #	Page	Part #	Page	Part #	Page	Part #	Page
3032	129	3098	40	3164	114	3227	130	3290	27	3353	41
3033	129	3099	40	3165	112	3228	45	3291	27	3354	105
3034	129	3100	29	3166	30	3229	53	3292	25	3355	26
3035	22	3101	75	3167	30	3230	45	3293	40	3356	60
3036	22	3102	89	3168	103	3231	34	3294	21	3358	23
3037	44	3103	29	3169	103	3232	53	3295	55	3359	60
3038	51	3104	30	3170	40	3233	25	3296	45	3360	21
3039	17	3105	30	3171	52	3234	25	3297	40	3361	27
3040	51	3106	30	3172	25	3235	53	3298	69	3362	56
3041	44	3107	30	3173	20	3236	80	3299	45	3363	34
3042	22	3108	23	3174	20	3237	98	3300	105,165	3364	40
3043	22	3109	52	3175	30	3238	76	3301	26	3365	40
3044	22	3110	75	3176	20	3239	31	3302	104	3366	16
3045	65	3111	75	3177	20	3240	31	3303	30	3367	55
3046	44	3112	59	3178	30	3241	59	3304	55	3368	16
3047	44	3113	59	3179	30	3242	54	3305	34	3369	55
3048	44	3114	45	3180	107	3243	106	3306	55	3370	16
3049	22	3115	79	3181	107	3244	54	3307	55	3371	56
3050	75	3116	23	3182	52	3245	54	3308	56	3372	56
3051	75	3117	75	3183	107	3246	54	3309	24	3373	73
3052	80	3118	76	3184	94	3247	70	3310	24	3374	33
3053	88	3119	34	3185	21	3248	70	3311	40	4001	132
3054	89	3120	89	3186	26	3249	70	3312	24	4002	132
3055	17	3121	90	3187	52	3250	70	3313	24	4003	132
3056	39	3122	123	3188	26	3251	70	3314	80	4004	132
3058	34	3123	123	3189	117	3252	70	3315	45	4005	132
3059	45	3124	123	3190	69	3253	70	3316	74	4101	132
3060	19	3125	123	3191	21	3254	54	3317	73	4102	132
3061	19	3126	123	3192	69	3255	77	3318	45	4103	132
3062	103	3127	123	3193	69	3256	77	3319	89	4104	132
3063	103	3128	123	3194	52	3257	76	3320	90	4105	132
3064	39	3129	23	3195	130	3258	87	3321	90	4107	132
3065	16	3130	21	3196	130	3259	89	3322	24	4112	132
3066	117	3131	21	3197	130	3260	54	3323	118	4113	132
3067	93	3132	52	3198	130	3261	40	3324	130	4114	132
3068	81	3133	52	3199	130	3262	21	3325	24	4115	132
3069	81	3134	120	3200	130	3263	54	3326	55	4117	132
3070	114	3135	120	3201	130	3264	104	3327	55	4119	132
3071	114	3136	120	3202	52	3265	23	3328	62	4122	132
3072	103	3137	120	3203	36	3266	23	3329	106	4123	132
3073	103	3138	121	3204	20	3267	26	3330	27	4124	132
3074	23	3139	121	3205	31	3268	104	3331	16	4125	132
3075	29	3140	120	3206	61	3269	18	3332	68	4126	132
3076	26	3141	120	3207	103	3270	44	3333	104	4127	132
3077	26	3142	120	3208	34	3271	104	3334	104	4129	132
3078	51	3143	120	3209	61	3272	59	3335	63	4133	132
3079	51	3144	131	3210	53	3273	54	3336	31	4135	132
3080	62	3145	131	3211	104	3274	60	3337	26	4137	132
3081	17	3146	103	3212	53	3275	54	3338	104	4145	132
3082	19	3147	106	3213	130	3276	23	3339	105	4147	132
3083	34	3148	113	3214	53	3277	60	3340	27	4149	132
3084	107	3149	105,165	3215	53	3278	23	3341	31	4200	133
3085	105,165	3150	17	3216	53	3279	26	3342	34	4201	133
3088	87	3151	109	3217	69	3280	23	3343	61	4202	133
3089	89	3152	111	3218	36	3281	104	3344	46	4203	133
3090	107	3153	112	3219	69	3282	24	3345	46	4204	133
3091	20	3154	109	3220	69	3283	129	3346	56	4205	133
3092	103	3158	112	3221	106	3284	40	3347	60	4210	133
3093	52	3159	112	3222	133	3285	55	3348	24	4211	133
3094	31	3160	109	3223	133	3286	24	3349	26	4212	133
3095	45	3161	112	3224	53	3287	60	3350	18	4213	133
3096	79	3162	112	3225	25	3288	69	3351	18	4214	133
3097	40	3163	112	3226	59	3289	69	3352	27	4215	133











Part #	Page	Part #	Page	Part #	Page	Part #	Page	Part #	Page	Part #	Page
5004	132	5942	105,165	CFS-40	158	MINI CHART		PLA-810	154		171
5005	132	5943	105,165	CLN-340	151	PARTS LIST		PLA-811	154	WTUE	170
5006	132	5944	105,165	CNA-102	158		184	PLA-812	154	WTUCD	170
5008	132	5945	92	CNA-145	158	MET-501	160	PLA-813	154	WK-3	137
5010	132	5946	94	CPN-250	158	MET-502	160	PLR-5	169	WK-10	137
5012	132	5947	88	CRA-500	150	MFA-50	161	POCA-402	161	WSC-240	149
5102	132	5948	91	CRT-1	141	MW-1000	163	POS-150	161	WW-72	137
5103	132	5949	133	CR-4	168	NK-5	152	POS-160	161		
5104	132	5950	133	CR-6	168	NKS-50	152	POS-260	161		
5106	132	5951	133	CTA-400	164	NRA-60	152	PPS-255	161		
5108	132	5952	89	DI-3	135	NT-11	165	PR-200	138	<u>BULBS</u>	
5110	132	5953	87	DI-5	135	NT11-1024	165	PR-200-1	138	D2R	128
5124	132	5954	87	DI-9	135	NT11-1/4-20		PRT-70	151	D2S	128
5126	132	5955	88	DISP-1	187		165	PRT-70	151	H-1	127
5401	132	5956	133	DISP-4	187	NT11-5/16-18		PT-217	139	H-3	127
5402	132	5957	133	DL-24	169		165	PTR-241	154	H-7	127
5501	132	5958	133	DRC-300	158	NT-15M		PW-15	137	H-8	127
5502	132	5959	106	DRP-1	110		161,165	QEC-120	161	H-9	127
5601	132	5960	106	DS-13	135	NT15M-4	165	RB-1	142	H-10	127
5602	132	5961	92	DS-15	135	NT15M-5	165	RB-8	139	H-11	127
5603	132	5962	88	DS-29	135	NT15M-6	165	SD-1402	143	H-12	127
5604	132	5963	89	ECA-130	160	NT15M-8	165	SD-1403	143	H-13	127
5606	132	5965	91	EFA-1	166	NT15M-10	165	SD-1404	144	MHL-880	127
5608	132	5967	87	EFA-2	166	OE CROSS		SD-1406	144	MHL-889	127
5801	132	5968	89	EFA-3	166	REF.-	172-181	SD-1407	145	MHL-890	127
5802	132	5970	133	EFA-4	166	PB-18	168	SD-1455	145	MHL-891	128
5803	132	5971	133	EFA-5	167	PD-121		SD-1465	146	MHL-899	128
5804	132	5972	133	EP-0	142		155,156	SD-1466	146	PR-2	125
5805	132	5973	133	EP-00	142	PD-122		SD-1467	147	PR-12	125
5806	132	5974	105,165	EP-3	142		155,156	SD-1470	147	T161	124
5808	132	5975	91	EP-4	142	PD-123		SD-2100	148	T24	124
5810	132	5976	88	EP-5	142		155,156	SD-5900	149	T24NA	124
5901	86	5977	90	EP-6	142	PD-124		SEMS-70	162	T916	124
5902	86	5980	87	EP-7	142		155,156	SQ-2000	140	T921	124
5903	86	5982	92	EP-8	142	PD-125		SRA-100	162	T922	124
5904	86	5983	91	EP-9	142		155,156	STGA-195	162	T1034	124
5905	87	5985	87	EP-10	142	PD-126		SWD-8	134	T1073	125
5906	87	5986	89	EP-11	142		155,156	SWD-10	134	T2357	125
5908	91	5987	87	EP-12	142	PD-127		TCA-290	162	37	124
5909	91	5988	87	EPS-13	142		155,157	TCN-400	151	53	124
5910	88	5989	86	EW-14	142	PD-128		TEK-530	164	57	124
5911	88	5990	94	FA-100	140		155,157	TP-50	140	67	124
5913	94	5991	90	FA-176	140	PD-129		TKS-105	162	73	124
5914	94	6000	138	FA-300	140		155,157	TXS-110	162	74	124
5916	92	ACC-131	164	FAX ORDER		PD-130		VTA-26	162	89	124
5917	92	AFA-12	158	FORM	185		155,157	VTC-50		90	124
5918	92	AF-100	158	FL-1400	163	PD-131		117,160		93	124
5919	92	B-12	169	FW-25	142		155,157	WEE PAK		97	124
5920	86	B-16	169	GM-160	140	PD-132		RAKS	IFC	158	124
5921	88	B-24	169	GMT-25	159		155,157			168	124
5922	91	BL-150	186	HG-8	136	PD-133		WEE PAK#1		194	124
5923	88	BPD-1/8	134	HLN-75	160		155,157	PARTS LIST		194NA	124
5924	86	BPD-7/64	134	HPB-9	159	PL-12	169	PAGE 182		199	124
5925	92	BPX-1/4	134	HPB-17	159	PL-24	169			211-2	126
5927	88	BPX-1/8	134	HST-65		PLA-801	153	WEE PAK #2		272	126
5928	94	BPX-11	134		122,150	PLA-802	153	PARTS LIST		317	126
5931	91	BPX-30	134	LPN-46	160	PLA-803	153	PAGE 183		561	126
5932	88	BRG-1	138	M-602	169	PLA-804	153			904	124
5936	86	BSWD-14	134	MC-1	186	PLA-805	153	WECD	186	906	124
5938	91	BSWD-83	134	MC-2	186	PLA-806	153	WE TRAK	170	906NA	124
5939	89	BUS-24	158	MC-3	186	PLA-807	153	WETRAK3		912	124
5940	89	CC-9-100	140	MC-4	186	PLA-808	154	170		912NA	124
5941	91	CC-9-M	140	MC-5	186	PLA-809	154	WE TRAK		916NA	124
								WORKSHEET		921NA	124



Part #	Page	Part #	Page	Part #	Page	Part #	Page	Part #	Page	Part #	Page
1003	124	17640	125								
1004	124										
1141	125										
1142	125										
1156	125										
1156NA	125										
1157	125										
1157N	125										
1157NA	125										
1295	125										
1295NA	125										
1445	125										
1816	125										
1891	125										
1893	125										
1895	125										
2040	128										
2057	125										
2057NA	125										
2357NA	125										
3057	126										
3057NA	126										
3155	126										
3156	126										
3156NA	126										
3157	126										
3157NA	126										
3357	126										
3357NA	126										
3457	126										
3457NA	126										
3496	125										
3497	125										
3757NA	126										
4057K	126										
4114K	126										
4157K	126										
4157NAK	126										
7440	125										
7440NA	125										
7441	125										
7443	125										
7443NA	125										
9003	127										
9004	127										
9005	127										
9005SX	127										
9006	127										
9006SX	127										
9007	127										
9011	127										
12023	125										
12498	125										
12516	125										
12594	125										
12814	125										
12818	126										
12821	125										
12844	126										
12854	126										
12866	126										
12961	125										
17638NA	125										

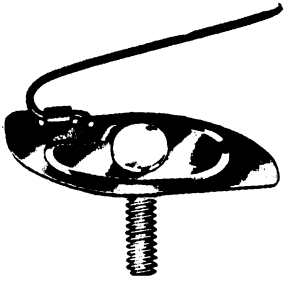
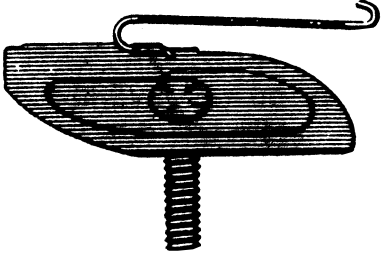
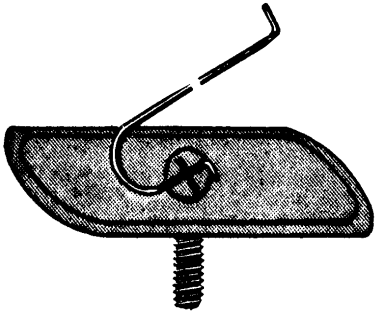
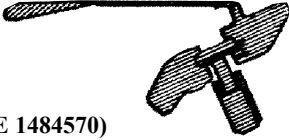

## MOULDING BOLTS & CLIPS

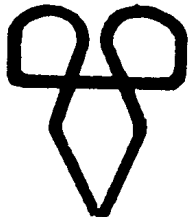
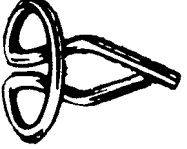
<p><b>146</b></p>  <p>(1624705, 6010093) 10-24 x 3/4" SCREW OLDSMOBILE, CADILLAC, CHEVROLET, FORD, CHRYSLER</p> <p style="text-align: center;">UNIT PKG.-25</p>	<p><b>147</b></p>  <p>10-24 x 3/4" SCREW GENERAL MOTORS, CHRYSLER, FORD, RAMBLER</p> <p style="text-align: center;">UNIT PKG.-25</p>	<p><b>150</b></p>  <p>10-24 x 3/4" SCREW (PLATE-1-3/8" X 5/8") GENERAL MOTORS, CHRYSLER, RAMBLER</p> <p style="text-align: center;">UNIT PKG.-25</p>	
<p><b>156</b></p>  <p>10-24 x 5/8" SCREW (PLATE:1-3/4" X 1/2") CHEVROLET, CHRYSLER FORD &amp; RAMBLER</p> <p style="text-align: center;">UNIT PKG.-25</p>	<p><b>161</b></p>  <p>(4676189) 10-24 x 3/4" SCREW (PLATE:2-1/2" LONG X 11/16" WIDE) GM-CHEVROLET &amp; BUICK</p> <p style="text-align: center;">UNIT PKG.-15</p>	<p><b>175</b></p>  <p>(OE 1484570) PUSH-IN (BLIND) MOULDING FASTENER (TOP:13/16" LONG X 3/8" WIDE) GM &amp; UNIVERSAL</p> <p style="text-align: center;">UNIT PKG.-25</p>	
		<p><b>777</b></p>  <p>10-24 HEX NUT-PLATED UNIT PKG.-100</p>	
<p><b>332</b></p>  <p>7/16" X 9/16" SIDE MOULDING CLIP</p> <p style="text-align: center;">UNIT PKG.-50</p>	<p><b>333</b></p>  <p>1/2" X 11/16" SIDE MOULDING CLIP</p> <p style="text-align: center;">UNIT PKG.-50</p>	<p><b>336</b></p>  <p>7/8" X 1" SIDE MOULDING CLIP</p> <p style="text-align: center;">UNIT PKG.-25</p>	<p><b>2402</b></p>  <p>(6002092) WIRE MOULDING CLIP 3/4" MOULDINGS CHRYSLER &amp; UNIVERSAL</p> <p style="text-align: center;">UNIT PKG.-100</p>

## MOULDING CLIPS

**341**



(OE-873359)  
(REPLACES-4492962)  
PLASTIC QUARTER PANEL,  
DOOR, WHEEL OPENING,  
AND NARROW VINYL TOP  
MOULDING  
ALL GM CARS- '66-'72  
& UNIVERSAL  
UNIT PKG.-50

**345**



(7731589)  
LANDAU TOP  
MOULDING CLIP  
(ALL MAKES & MODELS)  
ALSO; QUARTER PANEL  
REVEAL MOULDING CLIP  
GM PRODUCTS  
UNIT PKG.-50

**349**

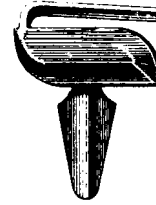

MOULDING FASTENER-NYLON  
FOR 1/2" TO 5/8" MOULDINGS  
UNIVERSAL & VW MODELS  
UNIT PKG.-50

**350**



(OE-4853108)  
CHEVROLET DOOR & QUARTER  
PANEL (USE IN 3/8" HOLE)  
UNIT PKG.-50

**351**

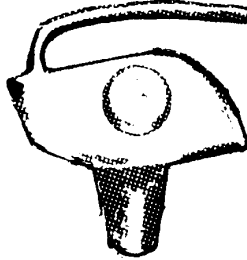

(OE-4883164)  
GENERAL MOTORS DOOR  
AND QUARTER PANEL  
USE IN 3/8" HOLE  
UNIT PKG.-50

**352**

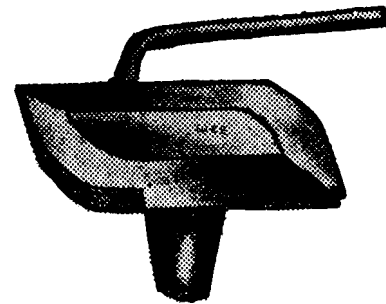

UNIVERSAL MOULDING CLIP  
RANGE: 1-1/4"-1-3/4"  
USE IN 3/8" HOLE  
UNIT PKG.-25

**2421**

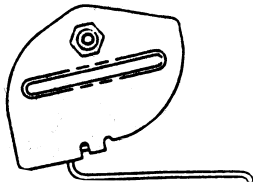

(OE-E9VB5420884AA)  
DOOR MOULDING RETAINER  
4 MM THREAD  
FORD/LINCOLN -'80 & UP  
UNIT PKG.-10

**1250**



ALL ALUMINUM SMALL  
FLANGE BLIND RIVET  
RIVET DIAMETER- 1/8"  
PANEL RANGE- 1/8"- 1/4"  
USE WITH PLASTIC  
FASTENER &  
GENERAL PURPOSE  
UNIT PKG.-250

**2142**

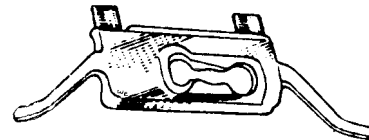

(OE-6003632)  
PLASTIC CLIP-FENDER  
TO WHEELHOUSE MOULDING  
CHRYSLER-'77 & UP  
UNIT PKG.-50

**2127**

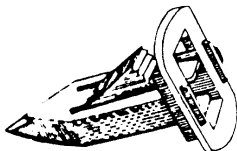

(9617200)  
NYLON  
HEADLINER CLIP  
ROOF, FRONT & REAR INNER  
SIDE PANEL-MOST GM CARS  
UNIT PKG.-25

**2163**

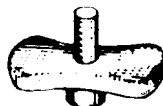

(OE-1247708)  
MOULDING CLIP  
VOLVO- '67 & UP  
UNIT PKG.-50

**2197**



(OE-000-988-1581)  
PLASTIC SIDE MOULDING CLIP  
MERCEDES-250/280, 350SL  
RED COLOR  
UNIT PKG.-100

## MOULDING CLIPS

**2221**  
(8727925)  
(20028569)

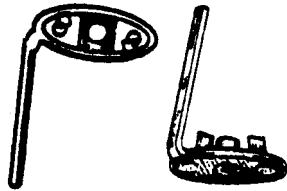

**FASTENER- FRONT AND REAR  
DOOR MOULDING- GM '75-'77  
UNIT PKG.-25**

**2165**



(OE-8799350)  
**NYLON MOULDING CLIP  
QUARTER PANEL & BELT  
GM CARS- '70-'77  
UNIT PKG.-50**

**2232**

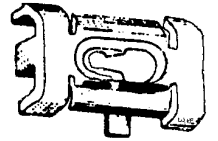

(OE-20175051), (15633873)  
**QUARTER BELT REVEAL  
MOULDING CLIP  
GM- '80 & UP  
UNIT PKG.-25**

**2233**



(OE-20136601)  
**BELT MOULDING CLIP  
CADILLAC  
ELDORADO & BIARRITZ  
REAR END  
'79-'81 & UP  
UNIT PKG.-25**

**2336**

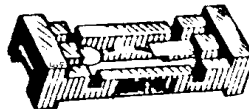

(OE-14022878)  
**PLASTIC MOULDING CLIP  
GM- '80 & UP  
UNIT PKG.-25**

**2229**



(OE-20199675)  
**BELT MOULDING CLIP-NARROW  
GM '80 & UP  
UNIT PKG.-25**

**2303**



VW (OE-411-853-575)  
BMW (OE-5113-6440-146)  
**SIDE MOULDING CLIP  
VOLKSWAGEN AND BMW  
UNIT PKG.-25**

**2308**

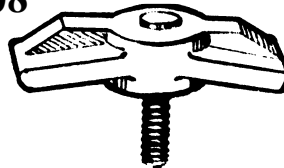

(OE-5113-1869-559)  
**BODY MOULDING  
T-BOLT-BMW  
UNIT PKG.-15**

**2254**



(OE-326177, 2193101)  
**SIDE & TAILGATE  
MOULDING CLIP  
CHEV. SUBURBAN &  
GM LIGHT TRUCKS  
UNIT PKG.-25**

**2301**



(OE-803-353-577)  
**PLASTIC MOULDING  
CLIP  
VOLKSWAGEN  
UNIT PKG.-25**

**2306**

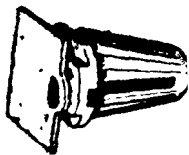

(OE-5147-840-961)  
**PLASTIC NUT  
PLUG-BMW  
UNIT PKG.-25**

**2315**



(OE-000-988-6081)  
**PLASTIC  
MOULDING CLIP  
MERCEDES BENZ  
UNIT PKG.-25**

**2311**



(OE-5113-1849-724)  
**PLASTIC MOULDING  
FASTENER  
BMW  
UNIT PKG.-10**

**2310**

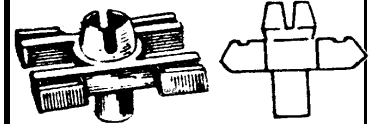

(OE-5113-1816-019)  
**PLASTIC MOULDING  
FASTENER  
BMW  
UNIT PKG.-15**



## MOULDING / GRILLE RETAINERS

**2421**  
(E9VB5420884AA)

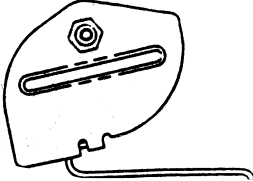

**DOOR MOULDING RETAINER**  
4 MM THREAD  
FORD-LINCOLN ('80 & UP)  
UNIT PKG.-10

**2419**

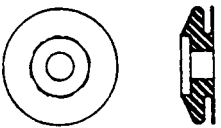

(OE-E7ZB61209808AC)  
**DOOR RETAINER-  
OUTSIDE BELT MOULDING**  
FORD MUSTANG  
1987 & UP  
UNIT PKG.-25

**2317**



(OE-000-988-7881)  
**PLASTIC MOULDING FASTENER**  
MERCEDES BENZ  
UNIT PKG.-25

**2293**



(20375022)  
**TORX PLASTIC WASHER HEAD**  
DOOR PANEL ATTACHING  
PONTIAC "FIERO"  
UNIT PKG.-10

6 MM SCREW

**3331**  
(11588650)

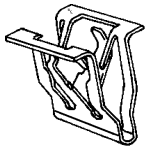

**RETAINER-INT. TRIM PANEL, BEZEL  
SCUFF PLATE & WINDSHIELD TRIM**  
(12MM WIDE X 17MM HIGH)  
GM CARS & LIGHT TRUCKS-'02 & UP  
UNIT PKG.-25

**3065**  
(4805770AA)



**GRILLE COVER RETAINER**  
25 MM OVERALL HEIGHT  
25 MM WIDTH  
CHRYSLER MINIVANS-'96 & UP  
UNIT PKG.-10

**2769**

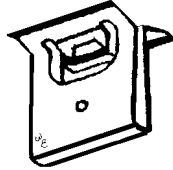

(25606274)  
**RETAINER-SIDE MARKER,  
PARKING LIGHT &  
REAR BUMPER  
REFLECTOR- GM**

UNIT PKG.-25

**2632**



(OE-91501-SG0-003)  
**BODY SIDE  
MOULDING CLIP**  
ACURA-'87 & UP

UNIT PKG.-25

**2633**



(OE-91534-SE0-000)  
**BODY SIDE  
MOULDING CLIP**  
HONDA-'86 & UP

UNIT PKG.-25

**2675**



(15686142;repl. 11561448)  
**RADIATOR GRILLE NUT**  
#8 SCREW  
ZINC PHOSPHATE  
GM TRUCKS- '93 & UP

UNIT PKG.-25

**3366**



(53326-52010)  
**PLASTIC HOOD MOULDING CLIP**  
TOYOTA- COROLLA,  
MATRIX, PRIUS & SIENNA  
2009 & UP  
UNIT PKG.-10

FOR 11 X 21 MM HOLE

**3368**  
(75395-33030)



**PLASTIC MOULDING  
RETAINER W/ SEALER**  
FENDER TRIM & DOOR PANELS  
TOYOTA/LEXUS  
ES 300 & RX 300  
1999-UP  
UNIT PKG.-15

HOLE SIZE- 9 MM  
FLANGE- 18 MM  
O/A LENGTH- 18 MM

**3370**  
(W708771-S300)









**PLASTIC RETAINER-COWL VENT,  
RADIATOR SHROUD & AIR DEFLECTOR**  
FORD/LINCOLN  
FULL SIZE SUV'S  
2003-UP  
UNIT PKG.-25

HOLE SIZE- 10 X 15 MM  
O/A LENGTH- 24 MM

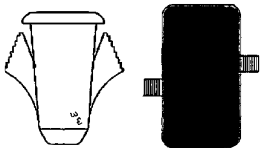
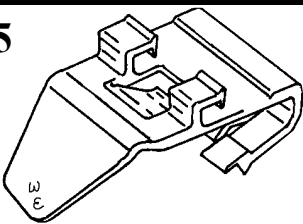
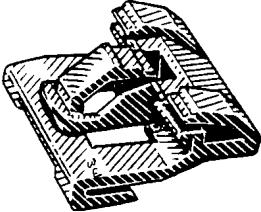

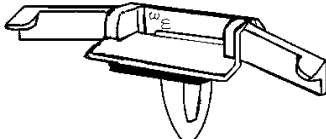
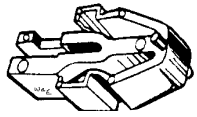
## MOULDING /GRILLE CLIPS

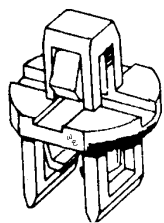
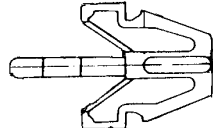
<p><b>2780</b></p>  <p>(N807872-S32B)  <b>RETAINER-  REAR &amp; SIDE LIGHTS</b>  <b>PANEL THICKNESS:  (.157"-.173")</b>  <b>FORD- '93 &amp; UP</b>  <b>UNIT PKG.-25</b></p>	<p><b>2784</b></p>  <p>(N806624-S191); (6502776)  <b>SIDE &amp; REAR LIGHT  ASSEMBLY CLIP</b>  <b>.034"-.043" THICK PANEL</b>  <b>FORD &amp; CHRYSLER</b>  <b>UNIT PKG.-25</b></p>	<p><b>2786</b></p>  <p>(22642007)  <b>RETAINER-FENDER BRACKET</b>  <b>4.2-1.81MM</b>  <b>(#8) SCREW SIZE</b>  <b>8.5 MM SQUARE HOLE</b>  <b>GM-'95 &amp; UP</b>  <b>UNIT PKG.-25</b></p>
<p><b>2892</b></p>  <p>(5FR56DX9)  <b>PLASTIC RETAINER  SILL MOULDING</b>  <b>JEEP-'98 &amp; UP</b>  <b>UNIT PKG.-20</b></p> <div style="border: 1px solid black; padding: 2px; margin-top: 5px;"> <p>HOLE SIZE-9 X 10 MM  HEAD DIAM.-11 X 20 MM  OVERALL LENGTH- 18 MM</p> </div>	<p><b>3055</b></p>  <p>(91561-S84-A01-M1)  <b>DOOR MOULDING RETAINER</b>  <b>LIGHT BLUE</b>  <b>HONDA ACCORD-'98 &amp; UP</b>  <b>UNIT PKG.-25</b></p>	<p><b>2960</b></p>  <p>(91510-SR3-003)  <b>BELT MOULDING CLIP</b>  <b>HONDA CIVIC-'92 &amp; UP</b>  <b>UNIT PKG.-10</b></p>
<p><b>3039</b></p>  <p>(10287926)  <b>FRONT &amp; REAR  DOOR MOULDING CLIP</b>  <b>GM-'97 &amp; UP</b>  <b>UNIT PKG.-25</b></p>	<p><b>3150</b></p>  <p>(91528-S01-A01)  <b>(REPLACES-91528-SR4-003)</b>  <b>DRIP RAIL MOULDING CLIP</b>  <b>HONDA-ACCORD, CIVIC</b>  <b>1995 &amp; UP</b>  <b>UNIT PKG.-15</b></p>	<p><b>2370</b></p>  <p>(90467-13008)  <b>GRILLE CLIP-TOYOTA</b>    <b>UNIT PKG.-10</b></p>
<p><b>3081</b></p>  <p>(15002520, 15682898)  <b>RADIATOR GRILLE CLIP</b>  <b>ZINC ORGANIC PLATING</b>  <b>GM-SMALL PICK-UPS  &amp; FULL SIZE VANS-'94 &amp; UP</b>  <b>UNIT PKG.-15</b></p>	<p><b>2378</b></p>  <p>(90651-689-0030)  (90651-689-9000)    <b>GRILLE RETAINER</b>  <b>HONDA</b>    <b>UNIT PKG.-10</b></p>	<p><b>2408</b></p>  <p>(58974-00008), (89421-80270)  <b>GRILLE CLIP- MITSUBISHI,  ISUZU,  HONDA, MAZDA,FORD-ESCORT</b>    <b>UNIT PKG.-20</b></p>

## DOOR MOULDING/ GRILLE CLIPS

**2195**



(003-988-1978)  
**PLASTIC RETAINER  
 GRILLE MOULDING  
 MERCEDES-BENZ  
 UNIT PKG.-50**

**2196**



(003-988-2078)  
**PLASTIC RETAINER  
 GRILLE MOULDING  
 MERCEDES-BENZ  
 (LARGER THAN W&E #2195)  
 UNIT PKG.-50**

**2175**



(25501771)  
**METAL SCREW RETAINER  
 (STAINLESS STEEL)  
 FOR HEADLAMP PANEL  
 OLDS- '80 & UP  
 UNIT PKG.- 50**

**2368**

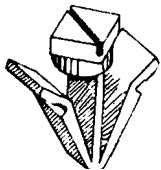

(62318-01W00)  
**GRILLE RETAINER  
 NISSAN-(GREY)  
 UNIT PKG.-10**

**2369**

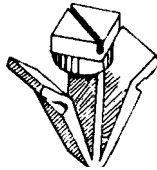

(62318-H8500)  
**GRILLE RETAINER  
 NISSAN-(BLACK)  
 UNIT PKG.-10**

**2300**



(171-853-695A)  
**PLASTIC GRILLE CLIP- VW  
 UNIT PKG.-25**

**2578**

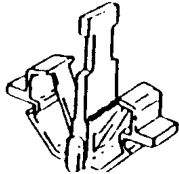

(90467-17004)  
**PLASTIC GRILLE CLIP  
 TOYOTA- '84 & UP  
 UNIT PKG.-15**

**2608**

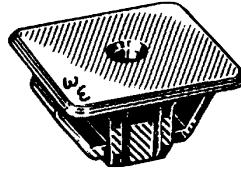

(91635-SM4-003)  
**HEADLAMP TO GRILLE SPACER  
 HONDA ACCORD-'90 & UP  
 UNIT PKG.-10**

SCREW SIZE-5 MM

**2651**



(55055098)  
**HEADLAMP GRILLE RETAINER  
 DODGE TRUCKS  
 UNIT PKG.-50**

HOLE SIZE-3.5 MM  
 HEAD DIAM.-11 MM

**3269**



(87756-3D000)  
**PLASTIC SIDE MOULDING  
 RETAINER WITH SEALER  
 HYUNDAI- 2002 & UP  
 KIA- 2004 & UP  
 UNIT PKG.- 15**

FOR 4.2 MM (#8) SCREW  
 14 MM SQUARE HEAD  
 OVERALL HEIGHT-11 MM

**3350**



(75315-S9A-004;REPL.75315-STK-A01)  
**PLASTIC RETAINER FRONT &  
 REAR DOOR MOULDING  
 HONDA CRV & ACURA RDX  
 2007 & UP  
 UNIT PKG.-15**

TOP HEAD 12 X 15 MM  
 O/A HEIGHT- 15.2 MM



**3351**



(75316-S9A-004)  
**PLASTIC RETAINER FRONT &  
 REAR DOOR MOULDINGS  
 HONDA CRV & ACURA RDX  
 2007 & UP  
 UNIT PKG.-15**

FOR 10 MM HOLE  
 14 X 16 MM HEAD

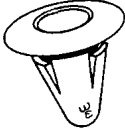
## GRILLE/ COWL CLIPS

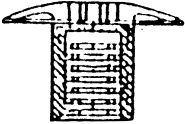
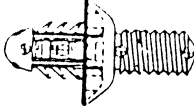
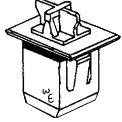
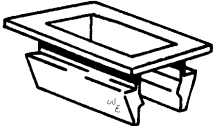
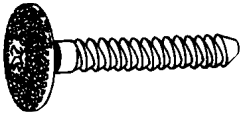
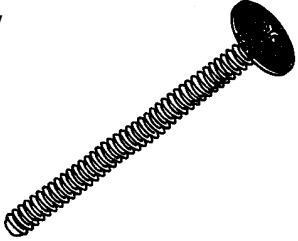
<p><b>3060</b></p>  <p>USE WITH W&amp;E #3061 (90467-08184) COWL VENT GROMMET TOYOTA 4 RUNNER, PRE-RUNNER, TACOMA &amp; TUNDRA- '95 &amp; UP UNIT PKG.-15</p>	<p><b>3061</b> (90467-07045-22)</p>  <p>USE WITH W&amp;E #3060 COWL VENT PIN TOYOTA-4 /PRE RUNNER, TACOMA &amp; TUNDRA-'95 &amp; UP UNIT PKG.-15</p> <div style="border: 1px solid black; padding: 2px; text-align: center;">HEAD O.D.-13 MM STEM LENGTH-15 MM</div>	<p><b>2598</b></p>  <p>(91501-SM4-003) COWL TOP RETAINER HONDA ACCORD-'90 &amp; UP UNIT PKG.-15</p> <div style="border: 1px solid black; padding: 2px; text-align: center;">HD.DIAM.-14 MM</div>
<p><b>2650</b></p>  <p>(6503339) COWL SCREEN STUD CAP T30 TORX DRIVE (USE WITH W&amp;E #2649) DODGE TRUCKS UNIT PKG.- 20</p> <div style="border: 1px solid black; padding: 2px; text-align: center;">HEAD DIAMETER-21 MM</div>	<p><b>2649</b></p>  <p>(6503336) COWL SCREEN STUD (USE WITH W&amp;E # 2650) DODGE TRUCKS UNIT PKG.-25</p> <div style="border: 1px solid black; padding: 2px; text-align: center;">HOLE SIZE-1/4"</div>	<p><b>3082</b></p>  <p>(90157-SPO-901) PLASTIC GRILLE RETAINER HONDA-ODYSSEY-'95 &amp; UP ACURA-'91 &amp; UP UNIT PKG.-10</p> <div style="border: 1px solid black; padding: 2px; text-align: center;">HOLE SIZE-8 MM SQUARE FLANGE--10 X 14 MM OVERALL HEIGHT- 15 MM</div>
<p><b>2935</b></p>  <p>(F7DB-5402316-AA) (W7016505; F6DZ-5402316-AA) COWL TOP VENT GRILLE GROMMET FOR 9 X 12 MM HOLE USE WITH W&amp;E #2936 OR #2937 FORD TAURUS/SABLE-'96 &amp; UP UNIT PKG.-50</p> <div style="border: 1px solid black; padding: 2px; text-align: center;">HD.DIAM.-14 MM LENGTH- 25 MM</div>	<p><b>2936</b></p>  <p>(W704881-S300; W701649-S) PHILLIPS HEAD NYLON COWL VENT SCREW (USE WITH W&amp;E # 2935) FORD TAURUS/SABLE-'96 &amp; UP UNIT PKG.-25</p> <div style="border: 1px solid black; padding: 2px; text-align: center;">HD.DIAM.-14 MM LENGTH- 25 MM</div>	<p><b>2937</b></p>  <p>(N811849-S300) (PICTURE -NOT ACTUAL SIZE) PHIL. HD NYLON COWL VENT SCREW (USE WITH W&amp;E # 2935) FORD TRUCKS/ LINCOLN TOWN CAR- '98 &amp; UP UNIT PKG.-15</p> <div style="border: 1px solid black; padding: 2px; text-align: center;">HD.DIAM.-14 MM, LENGTH- 52 MM</div>

## COWL/ BUMPER CLIPS

**3091**

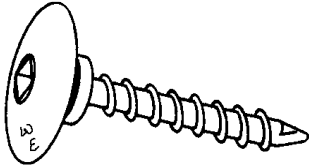

(CHRY 6503401,6503819);  
(GM 25631448)

PLASTIC SCREW-7.5 X 34 MM  
SQUARE DRIVE- TRUSS HEAD  
HOLDS FOAM TO BUMPER FASCIA GM  
& CHRYSLER-'93 & UP-BLACK  
UNIT PKG.-15

HOLE SIZE-7.5 MM  
HEAD DIAM.-22 MM  
LENGTH UNDER HD-34 MM  
SHOULDER DIAM. -9 MM

**2968**

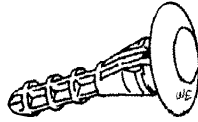

(90108-SW3-003)

BUMPER RETAINER  
HONDA/ACURA-ACCORD,  
PRELUDE & ODYSSEY  
'95 & UP

UNIT PKG.-10

HOLE SIZE-6 MM  
HEAD DIAM.-16 MM  
OVERALL HEIGHT-23 MM

**3204**

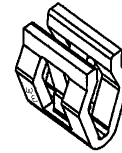

(11561857)

PLASTIC BUMPER  
MOULDING CLIP  
GM- 2007  
CADILLAC ESCALADE,  
GMC YUKON, CHEVY  
SUBURBAN & TAHOE

UNIT PKG.-25

**3173**

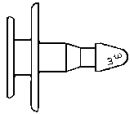

(90602-SXO-0030)

PLASTIC COWL VENT  
RETAINER  
HONDA/ACURA 1995 & UP  
USE WITH W&E-#3174

UNIT PKG.-15

UPPER HD DIAM.-12 MM  
OVERALL LENGTH-18 MM

**3174**



(90603-SXO-0030)

PLASTIC COWL VENT  
GROMMET WITH SEALER  
HONDA/ACURA-'95 & UP  
USE WITH W&E- #3173  
UNIT PKG.-15

HOLE SIZE-6 X 20 MM  
HEAD DIAM.-14 X-28 MM

**2372**



(90676-671-0030)

BUMPER RETAINER  
SPLASH SHIELD  
FRONT & REAR  
HONDA

UNIT PKG.-15

**3177**



(90603-S7S-0030)

PLASTIC COWL VENT GROMMET  
WITH SEALER  
HONDA/ ACURA-2003 & UP  
USE WITH W&E- #3176

UNIT PKG.-10

HOLE SIZE-6 X 20 MM  
HEAD DIAM.-10 X-24 MM

**3176**



(90602-S7S-0030)

PLASTIC COWL VENT  
RETAINER  
HONDA/ACURA-2003 & UP  
USE WITH W&E- #3177

UNIT PKG.-20

UPPER HD DIAM.-12 MM  
OVERALL LENGTH-11 MM

**2384**

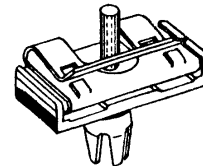

(OE-1304967)

PLASTIC BUMPER COVER  
MOULDING CLIP  
FRONT & REAR  
VOLVO-'83 & UP

UNIT PKG.-10



## BUMPER/GRILLE/ROCKER MOULDING RETAINERS

**3185**

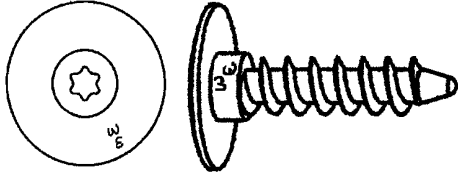

(06507866AA)  
**BUMPER COVER RETAINER**  
 (T25 TORX)  
**DODGE DURANGO 2004-2006**  
**BLACK NYLON**  
**UNIT PKG.-25**

HEAD DIAM.-22 MM, LENGTH-36.5 MM

**3131**

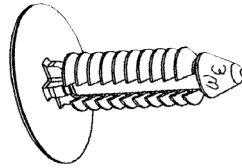

(W708035-S300)  
**REAR BUMPER**  
**COVER RETAINER**  
 (USE WITH W&E#3130)  
**FORD EXPEDITION-**  
**2003 & UP**  
**UNIT PKG.-25**

HOLE SIZE-7 MM  
 HD.DIAM.-21 MM  
 STEM LENGTH-25 MM

**3130**

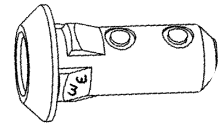

(W709629-S300);  
 (W708045-S300)  
**REAR BUMPER COVER**  
**GROMMET**  
 (USE WITH W&E#3131)  
**FORD EXPEDITION**  
**2003 & UP**  
**UNIT PKG.-25**

HOLE SIZE-9.5 MM  
 HD.DIAM.-15 MM  
 OVERALL HEIGHT-25 MM

**3294**



(52575-30180)  
**PLASTIC REAR BUMPER**  
**COVER RETAINER**  
**TOYOTA - LEXUS GS SERIES**  
**2006 & UP**

**UNIT PKG.- 10**

OUTSIDE DIMENSIONS-17 X 18 MM

**3262**



(75392-35200)  
 (REPLACES-75392-04010)  
**BUMPER COVER, SPOILER**  
**& FENDER FLARE RETAINER**  
**TOYOTA-CAMRY, TACOMA,**  
**FJ CRUISER & RAV 4**  
**2005 & UP**  
**UNIT PKG.- 15**

HOLE SIZE-4.5 X 16 MM  
 13 X 26 MM HEAD  
 OVERALL HEIGHT- 27 MM

**3191**

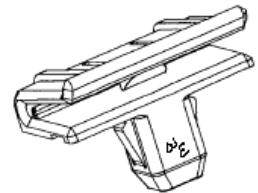

(90084-46020)  
**PLASTIC FRONT BUMPER**  
**STRIP RETAINER**  
**TOYOTA CAMRY AND**  
**AVALON -2000-2006**

**UNIT PKG.-10**

HOLE SIZE-9 MM (SQUARE)  
 HEAD -23 MM X 30 MM  
 OVERALL HEIGHT-19 MM

### “METRIC CONVERSION TABLE”

Millimeter/Decimal/Fractional Equivalents

METRIC	DEC.	FRACT.	METRIC	DEC.	FRACT.	METRIC	DEC.	FRACT.
0.3968mm	.0156"	1/64"	13mm	.5118"		29mm	1.1417"	
0.7924	.0312	1/32	14	.5512		30	1.1811	
1	.0394		14.2875	.5625	9/16"	35	1.3779	
1.5875	.0625	1/16	15	.5905		38.1	1.5000	1 1/2"
2	.0787		15.8750	.625	5/8	40	1.5748	
3	.1181		16	.6299		45	1.7716	
3.175	.1250	1/8	17	.6693		50	1.9685	
4	.1575		18	.7087		50.8	2.000	2
4.7625	.1875	3/16	19	.748		55	2.1653	
5	.1968		19.05	.750	3/4	60	2.3622	
6	.2362		20	.7874		63.5	2.500	2 1/2"
6.35	.2500	1/4	21	.8268		65	2.5590	
7	.2756		22	.8661		70	2.7559	
7.9375	.3125	5/16	22.23	.875	7/8	75	2.9527	
8	.3150		23	.9055		76.2	3.000	3
9	.3543		24	.9449		80	3.1496	
9.525	.375	3/8	25	.9842		85	3.3464	
10	.3937		25.4	1.0000	1	90	3.5433	
11	.4331		26	1.0236		95	3.7041	
11.1125	.4375	7/16	27	1.0630		100	3.9370	
12	.4724		28	1.1024		101.6	4.000	4
12.7	.5000	1/2						

**3360**

(25744385)



**PLASTIC ROCKER**  
**MOULDING RETAINER**  
 (FOR 9 MM HOLE; 23 X 46 MM HEAD)  
**GM-CADILLAC CTS, CTS WAGON**  
**& CTS COUPE- 2011 & UP**  
**UNIT PKG.-15**

## ROCKER PANEL MOULDING CLIPS

**2109**

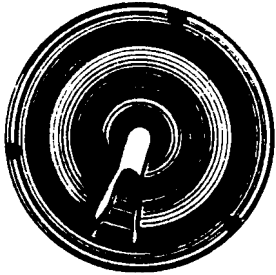

(OE- 3986976)  
**ROCKER PANEL MOULDING  
 FASTENER GM PRODUCTS  
 '71-'78**

**UNIT PKG.-25**

**2755**

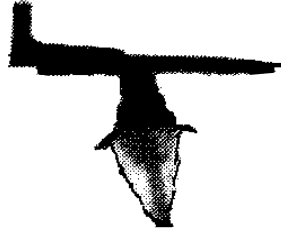

(OE-N/A)  
**MOULDING RETAINER  
 ROCKER PANEL  
 TOYOTA CAMRY**

**UNIT PKG.-5**

**3035**

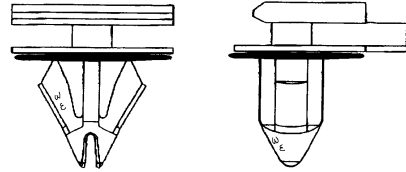

(11518357)  
**PLASTIC ROCKER PANEL  
 MOULDING CLIP WITH SEALER  
 GM- CHEV. AVALANCHE-2002  
 UNIT PKG.-15**

**HOLE SIZE-9 MM  
 TOP HEAD DIAM.-14 X 20 MM  
 OVERALL HEIGHT-20 MM**

**3036**

(25722671)

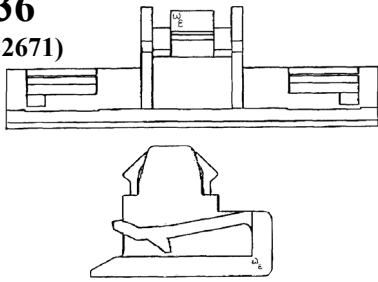

**PLASTIC ROCKER PANEL  
 MOULDING CLIP  
 2002 GM: CADILLAC, PONTIAC,  
 OLDSMOBILE & BUICK  
 UNIT PKG.-10**

**WIDTH-7/8"  
 OVERALL DIAM.-2"**

**3042**

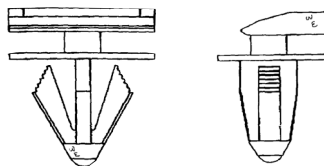

(10423553)  
**PLASTIC ROCKER  
 MOULDING RETAINER  
 GM-2002 PONTIAC & CHEVY  
 UNIT PKG.-15**

**HOLE SIZE-8 MM  
 TOP HEAD DIAM.-12 X 20 MM  
 BOTTOM HEAD-15 X 20 MM  
 OVERALL HEIGHT-21 MM**

**3043**

(25724529)

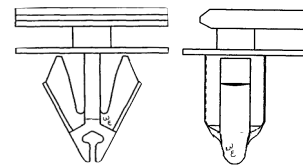

**PLASTIC ROCKER PANEL  
 MOULDING CLIP-NATURAL  
 GM 2002**

**UNIT PKG.-15**

**HOLE SIZE-8 MM  
 TOP HEAD DIAM.-14 X 20 MM  
 BOTTOM HEAD-16 X 20 MM  
 OVERALL HEIGHT-29 MM**

**3044**

(22603384)

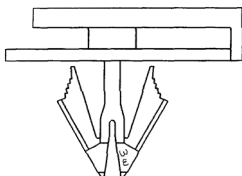

**PLASTIC ROCKER PANEL MOULDING CLIP-  
 NATURAL; GM-'99 & UP  
 UNIT PKG.-15**

**HOLE SIZE-8 MM, TOP HEAD DIAM.- 19 X 26 MM  
 LOWER HEAD-19 X 30 MM  
 OVERALL HEIGHT-22.4 MM**

**3049**

(10411395;10431761)

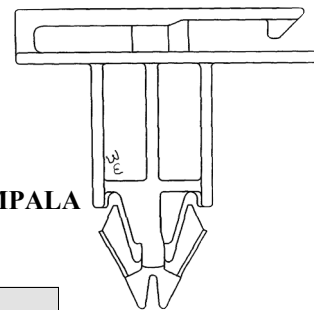

**PLASTIC ROCKER  
 MOULDING CLIP  
 CHEVY MONTE CARLO & IMPALA  
 2000 & UP  
 UNIT PKG.-15**

**HOLE SIZE-7/16"  
 TOP HEAD DIAM.-11/16" X 1-1/2"  
 OVERALL HEIGHT-1-37/64"**

## ROCKER PANEL MOULDING CLIPS

**3074**  
(91513-SM4-000)

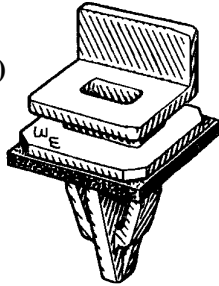

**ROCKER PANEL MOULDING  
RETAINER W/SEALER**  
HONDA ACCORD & CIVIC  
ACURA-'90 & UP  
UNIT PKG.-10

HOLE SIZE-12 MM  
HEAD DIAM.-20 MM X 20 MM

**3108**

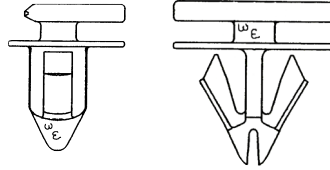

(25693852)  
**PLASTIC ROCKER PANEL  
MOULDING RETAINER**  
GM-'95 & UP  
UNIT PKG.-25

HOLE SIZE-9 MM  
TOP HEAD DIAM.-14 X 20 MM  
OVERALL HEIGHT-20 MM

**3116**



(PICTURE NOT ACTUAL SIZE)  
(10352799)  
(REPLACES-10431524)  
**PLASTIC ROCKER PANEL  
MOULDING RETAINER**  
CHEVY-'2000 & UP

UNIT PKG.-15

HOLE SIZE-7 MM  
HEAD DIAM.-17 X 33 MM  
OVERALL HEIGHT-20 MM

**3129**



(PICTURE NOT ACTUAL SIZE)  
(10352803)  
(REPLACES-10437565)  
**PLASTIC ROCKER PANEL  
MOULDING RETAINER**  
CHEVY-'2000 & UP  
UNIT PKG.-10

HOLE SIZE-7 MM  
HEAD DIAM.-12 X 33 MM  
OVERALL HEIGHT-20 MM

**3265**



(87758-3D000)  
**PLASTIC DOOR AND  
ROCKER PANEL MOULDING  
CLIP WITH SEALER**  
HYUNDAI- 2002 & UP;  
KIA- 2004 & UP  
UNIT PKG.- 15

TOP HEAD DIAM.-16 X 20 MM  
OVERALL HEIGHT-15 MM

**3266**



(87756-38000)  
**PLASTIC DOOR AND  
ROCKER PANEL MOULDING  
CLIP WITH SEALER**  
HYUNDAI- 1995 & UP  
KIA- 2001 & UP

UNIT PKG.- 15

TOP HEAD DIAM.-8 X 9 MM  
OVERALL HEIGHT-15 MM

**3276**

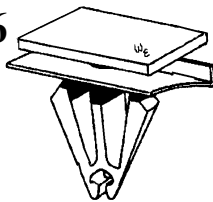

(10323057)  
**PLASTIC ROCKER  
PANEL RETAINER**  
GM-BUICK, CHEVROLET  
PONTIAC AND SATURN  
UNIT PKG.- 15

FOR 9 MM HOLE  
TOP HEAD DIAM.-12 X 20 MM  
OVERALL LENGTH-15 MM

**3278**

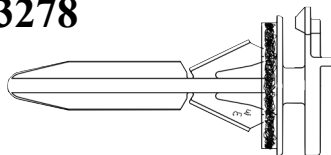

(11589244; REPL.-11569973)  
**PLASTIC RETAINER WITH  
SEALER; ROCKER PANEL &  
REAR MOULDING**  
GM-CHEVY & GMC-'02-'07  
UNIT PKG.- 10

FOR 9 MM HOLE  
TOP HEAD DIAM.-12 X 21 MM  
OVERALL LENGTH-43 MM

**3280**



(PICTURE NOT ACTUAL SIZE)  
(11518988; REPL.-11609303)  
**PLASTIC RETAINER  
WITH SEALER**  
**ROCKER PANEL MOULDING**  
GM/GMC SMALL TRUCKS &  
HUMMER-2002 & UP  
UNIT PKG.- 15

FOR 9 MM HOLE  
TOP HEAD DIAM.-12 X 21 MM  
OVERALL LENGTH-22 MM

**3358**



(25796285)  
**PLASTIC DRIP  
MOULDING  
RETAINER W/ SEALER**  
GM-CADILLAC CTS  
2008 & UP  
UNIT PKG.-15

HOLE SIZE 7 MM  
TOP HEAD 7 X 15 MM  
BOTTOM HEAD 13 X 26 MM

# ROCKER PANEL MOULDING/ FENDER/ WHEELHOUSE CLIPS

**3282**

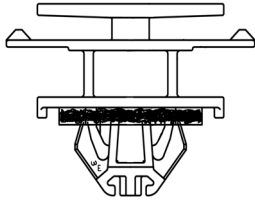

(15872008; REPLACES-11561491)  
**PLASTIC RETAINER WITH SEALER**  
**ROCKER PANEL MOULDING**  
**GM-CHEVY EQUINOX**  
**PONTIAC TORRENT**  
**2006 & UP**

**UNIT PKG.- 10**

**FOR 9 MM HOLE**  
**TOP HEAD DIAM.-20 X 30 MM**  
**OVERALL LENGTH-28 MM**

**3286**

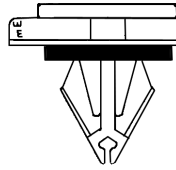

(11609923)  
**PLASTIC ROCKER MOULDING**  
**RETAINER WITH SEALER**  
**GM-PONTIAC G6**  
**CHEVY CAMARO**  
**2006 & UP**  
**UNIT PKG.- 10**

**FOR 9 MM HOLE**  
**TOP HEAD DIAM.-12 X 20 MM**  
**OVERALL HEIGHT-21 MM**

**3309**

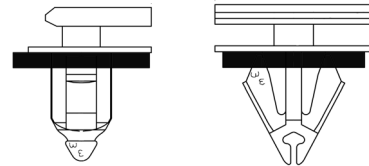

(5480852)  
**PLASTIC ROCKER PANEL**  
**MOULDING RETAINER**  
**WITH SEALER**  
**GM-CHEVY EQUINOX**  
**PONTIAC TORRENT**  
**2005 & UP**  
**UNIT PKG.-10**

**FOR 9 MM HOLE**  
**TOP HEAD DIAM.-14 X 20MM**  
**OVERALL HEIGHT-21 MM**

**3310**

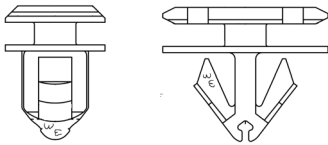

(15127746)  
**PLASTIC MOULDING RETAINER**  
**FENDER, LIFT GATE**  
**GM-CHEVY, PONTIAC, BUICK,**  
**GMC- 2005 & UP**  
**UNIT PKG.-15**

**FOR 9 MM HOLE**  
**TOP HEAD DIAM.-12 X 20 MM**  
**OVERALL HEIGHT-17 MM**

**3312**

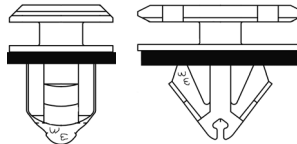

(11562250)  
**ROCKER PANEL, SIDE**  
**MOULDING RETAINER**  
**WITH SEALER**  
**INT. SEAT APPLIQUE**  
**GM-SATURN- 2005 & UP**  
**NATURAL PLASTIC**  
**UNIT PKG.-15**

**FOR 9 MM HOLE**  
**TOP HEAD DIAM.-12 X 20 MM**  
**OVERALL HEIGHT-16 MM**

**3313**

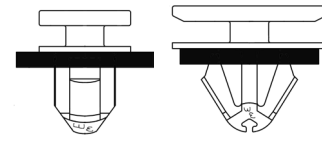

(11571175)  
**ROCKER PANEL**  
**MOULDING RETAINER**  
**WITH SEALER**  
**GM-SATURN, CADILLAC, GMC**  
**2005 & UP**  
**ORANGE PLASTIC**  
**UNIT PKG.-15**

**FOR 9 MM HOLE**  
**TOP HEAD DIAM.-12 X 20 MM**  
**OVERALL HEIGHT-16 MM**

**3322**

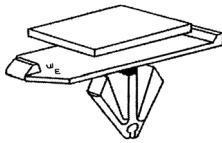

(11562563)  
**PLASTIC ROCKER PANEL**  
**MOULDING RETAINER**  
**GM-CHEVY MALIBU 2008 & UP**  
**UNIT PKG.-15**

**FOR 9 MM HOLE**  
**TOP HEAD DIAM.-12 X 32 MM**  
**OVERALL HEIGHT-15 MM**

**3325**

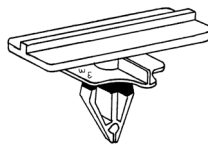

(W709767-S300; REPL. F57Z-16241-AB)  
**PLASTIC ROCKER PANEL**  
**MOULDING RETAINER**  
**FORD MUSTANG 2001 & UP**  
**UNIT PKG.-15**

**FOR 9 MM HOLE**  
**TOP HEAD DIAM.-14 X 40 MM**  
**OVERALL HEIGHT-19 MM**

**3348**

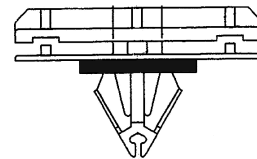

(55157055-AA; 55157065-AA)  
**PLASTIC FRONT & REAR**  
**FENDER MOULDING**  
**RETAINER WITH SEALER**  
**JEEP LIBERTY-2002-UP**  
**UNIT PKG.-15**

**FOR 9 MM HOLE**  
**TOP HEAD DIAM.-14 X 38 MM**  
**STEM LENGTH-15 MM**



## FENDER/WHEELHOUSE CLIPS

**2495**

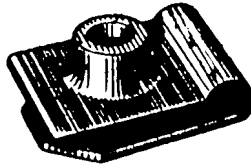

(53879-22010)  
**BLACK NYLON "U" NUT**  
 (28.5 MM LONG X 19 MM WIDE)  
 TAKES #14 SCREW  
 FENDER, WHEELHOUSE  
 TOYOTA  
 UNIT PKG.-15

**2496**

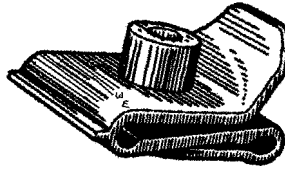

(53879-14010A,-14020,-22030;  
 94840226; LA0156135)  
**BLACK NYLON "U" NUT**  
 31 MM LONG X 20 MM WIDE  
 #10 SCREW; FNDR WHEELHOUSE  
 TOYOTA, GM, & MAZDA  
 UNIT PKG.-10

**2582**

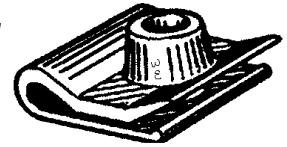

(63848-D0100)  
**BLACK NYLON "U" NUT**  
 21 MM LONG X 20 MM WIDE  
 TAKES #12 SCREW  
 FENDER, WHEELHOUSE  
 NISSAN  
 UNIT PKG.-15

**2894**

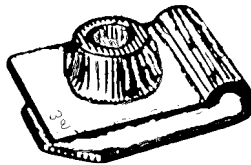

(90467-04009)  
**NATURAL NYLON "U" NUT**  
 30 MM LONG X 18 MM WIDE  
 (WIDER PANEL RANGE THAN  
 W&E #2495)  
 TOYOTA  
 UNIT PKG.-10

**2910**

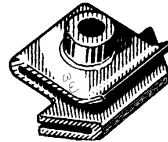

(63848-D4000)  
**BLACK NYLON "U" NUT**  
 22 MM LONG X 31 MM WIDE  
 TAKES #12 SCREW  
 FENDER, WHEELHOUSE  
 NISSAN SENTRA  
 UNIT PKG.-10

**2911**

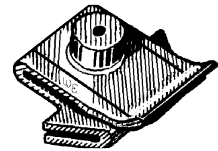

(63848-35F00)  
**BLACK NYLON "U" NUT**  
 32 MM LONG X 20 MM WIDE  
 TAKES #10 SCREW  
 FENDER, WHEELHOUSE  
 NISSAN-MAXIMA & 240 SX  
 UNIT PKG.-15

**3172**

(76882-OM000)  
**PLASTIC "U" NUT**  
 FENDER WHEELHOUSE  
 OUTSIDE DIAM.-19 X 20 MM  
 TAKES 5 MM (#10) SCREW  
 NISSAN- 1995 & UP  
 UNIT PKG.-25



**3225**

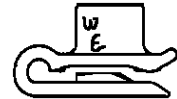

(B4555-6135)  
 (REPLACES- B37F-50B11)  
**PLASTIC U-NUT**  
 BUMPER COVER &  
 FRONT AIR DEFLECTOR  
 TAKES 5 MM (#10) SCREW  
 (OUTSIDE DIMENSIONS-  
 20 X 21 MM)  
 MAZDA-2003 & UP  
 UNIT PKG.-25

**3234**



(47749-58010)  
**PLASTIC PIN-FRONT**  
 FENDER & BUMPER COVER  
 TOYOTA 4 RUNNER, SOLARA,  
 HIGHLANDER, & SIENNA  
 LEXUS-GX 470- 2000 & UP  
 (USE WITH W&E #3233 CLIP)  
 UNIT PKG.-10

HEAD DIAM.-16 MM  
 OVERALL LENGTH-28 MM

**3233**



(53879-58010)  
**PLASTIC RETAINER-FRONT**  
 FENDER & BUMPER COVER  
 TOYOTA 4 RUNNER, SOLARA,  
 HIGHLANDER & SIENNA  
 LEXUS-GX 470 2000 & UP  
 (USE WITH W&E #3234 PIN)  
 UNIT PKG.-4

OUTSIDE DIMENSIONS: 25 X 35 MM

**3292**



(53879-16010, 53879-17020)  
**PLASTIC RETAINER FRONT**  
 BUMPER COVER & FENDER LINER  
 OUTSIDE DIM.-20 MM X 27 MM  
 USE WITH #10 SCREW  
 TOYOTA - LEXUS -MR2,GS,LS, & IS  
 SERIES - 2000 & UP  
 UNIT PKG.- 15



## FENDER/BUMPER WHEELHOUSE CLIPS

**3076**

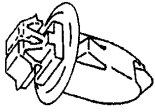

(90904-67037)

FENDER MOULDING  
RETAINER-RED PLASTIC  
TOYOTA TRUCKS & SUV'S  
2001 & UP  
UNIT PKG.-15

HOLE SIZE-9 MM SQUARE  
HEAD DIAM.-17 MM  
OVERALL HEIGHT-20 MM

**3077**

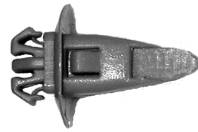

(90904-67036)

FENDER MOULDING RETAINER  
BLUE PLASTIC  
TOYOTA TRUCKS/SUV-2001 & UP  
UNIT PKG.-15

HOLE SIZE-9 MM SQUARE  
HEAD DIAM.-17 MM  
OVERALL HEIGHT-24 MM

**3186**

(75396-35020)

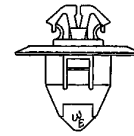

(REPLACES-75495-35010)  
MOULDING RETAINER-  
SIDE AND FENDER  
TOYOTA, LEXUS 2003 & UP  
BLUE PLASTIC  
UNIT PKG.-15

HOLE SIZE-9 MM SQUARE  
HEAD DIAM.-17 MM  
OVERALL HEIGHT-17 MM

**3188**

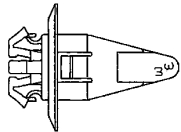

(75395-35070)

(REPLACES 75397-35010)  
MOULDING RETAINER-  
SIDE AND FENDER  
TOYOTA, LEXUS 2003 & UP  
(ORANGE PLASTIC)  
UNIT PKG.-15

HOLE SIZE-9 MM SQUARE  
HEAD DIAM.-17 MM  
OVERALL HEIGHT-23 MM

**3301**

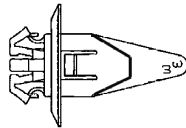

(90467-11110)

FENDER LINER FLARE  
RETAINER-PLASTIC-YELLOW  
TOYOTA SUV/TRUCKS-'96 & UP

UNIT PKG.-15

HEAD DIAM.-17 MM  
STEM LENGTH-17 MM  
OVERALL HEIGHT- 25 MM

**3267**

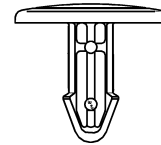

(91501-SNA-003)

(REPLACES-91501-SEA-003)  
FENDER LINER  
TRIM RETAINER  
HONDA CIVIC 2006 & UP

UNIT PKG.-15

HOLE SIZE-6 MM  
HEAD DIAM.-20 MM  
OVERALL HEIGHT- 19 MM

**3279**

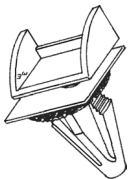

(10297370)

PLASTIC RETAINER  
WITH SEALER- BODY  
& FENDER MOULDING  
GM-VANS & HUMMER  
'97 & UP  
UNIT PKG.-10

HOLE SIZE-9 MM  
TOP HEAD SIZE-12 X 20 MM  
OVERALL LENGTH-25 MM

**3337**



(53867-47020)

PLASTIC FRONT FENDER  
RETAINER W/SEALER  
TOYOTA PRIUS  
'05-UP

UNIT PKG.-10

FOR 10 X 16 MM HOLE

**3355**



(90682-SEA-003)

PLASTIC FENDER  
LINER RETAINER  
HONDA & ACURA  
2004 & UP

UNIT PKG.-25

SQ HOLE SIZE-9 MM  
HEAD DIAM.- 20 MM  
O/A LENGTH-14 MM

**3349**



(91502-S9A-003)

PLASTIC RETAINER W/  
SEALER FRONT &  
REAR BUMPER  
MOULDING  
HONDA CRV-2002 & UP  
UNIT PKG.-10

HEAD 14 X 26 MM  
O/A HEIGHT 28 MM

## FENDER/ BUMPER/ MISC. CLIPS

**2679**



(W700548S300)  
SCUFF PLATE RETAINER  
5 X 24 MM PHILLIPS WASHER  
HEAD SCREW- BLACK NYLON  
FORD- CONTOUR & MYSTIQUE  
UNIT PKG.-50

**2809**

(CHRY.-5183468AA)  
(GM-25535963)  
(FORD-N811772S)

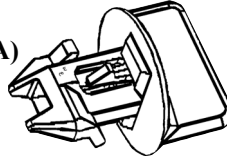

ENGINE COMPARTMENT  
REAR SIDE SHIELD RETAINER  
18 MM FLANGE  
24.3 MM O/A LENGTH  
UNIT PKG.- 25

**2919**

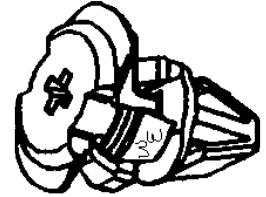

(15025531), (15764320)  
RETAINER- RADIATOR & GRILLE  
GM-C & K TRUCKS-'99 & UP  
UNIT PKG.-5

**2945**

(15733971)

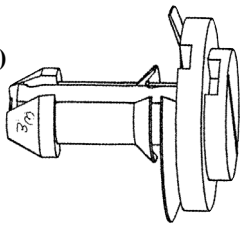

PLASTIC DRIVE RIVET BLACK  
FRONT AIR DAM TO BUMPER  
(USE WITH W&E # 2946)  
GM-C,K TRUCKS -'99 & UP

UNIT PKG.-15

**2946**

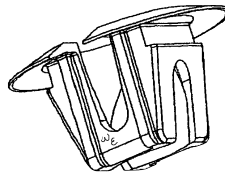

(15733970)  
PLASTIC GROMMET-BLACK  
FRONT AIR DAM  
(USE WITH W&E #2945)  
GM  
UNIT PKG.-25

HOLE SIZE-14 X 16 MM  
FLANGE O.D.-28 MM

**3352**



(91513-SMG-E11)  
PLASTIC FENDER MOULDING  
RETAINER WITH SEALER  
HONDA CRV & ELEMENT  
2007 & UP  
UNIT PKG.-20

FOR 7 MM HOLE  
BOTTOM HD-DIM. 10X19 MM

**3291**

(53879-50020)



PLASTIC RETAINER  
(USE WITH W&E #3290)  
FRONT BUMPER COVER  
& FENDER LINER  
TOYOTA-LEXUS-GS,IS, & LS  
MODELS - 2008 & UP  
UNIT PKG.- 10

OUTSIDE DIAM.-25 X 35 MM

**3290**



(47749-50090)  
PLASTIC PIN  
(USE WITH W&E #3291)  
FRONT BUMPER COVER &  
FENDER LINER  
TOYOTA - LEXUS-GS,IS,& LS  
MODELS - 2008 & UP

UNIT PKG.- 20

HEAD DIAM.-10 MM  
OVERALL LENGTH-26 MM

**3340**

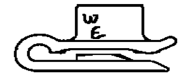

(90189-06131)  
PLASTIC U-CLIP  
ENGINE SHIELD RETAINER  
(18 X 30 MM O/A DIMENSIONS)  
(FOR #12 SCREW)  
TOYOTA PRIUS-'06 & UP  
UNIT PKG.-10

**3330**

(11610049)



PLASTIC  
BUMPER COVER  
TURN & LOCK  
RETAINER

(19 MM FLANGE;  
24.5 MM O/A LENGTH)  
GM-SUV'S-2007 & UP  
UNIT PKG.- 15

**3361**

90467-09212

PLASTIC RETAINER-INTERIOR  
QUARTER PANEL & COWL TRIM  
TOYOTA-CAMRY, SEQUOIA & TUNDRA  
LEXUS-ES-350 & HS HYBRID  
UNIT PKG.- 25



HOLE SIZE-8.5 MM  
TOP HD-13X18 MM;BOTTOM HD 18  
MM; O/A HEIGHT-16 MM

## WEATHER STRIP CLIPS

**1206**

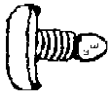

(OE-4876498)  
**WEATHERSTRIP RETAINER  
 PLASTIC NAIL FASTENER  
 GM, FORD & UNIVERSAL**

**UNIT PKG.-100**

**HOLE SIZE-3/16"**

**2207**



(1616923)  
**WEATHERSTRIP RETAINER  
 AND GENERAL USE  
 GM & UNIVERSAL  
 UNIT PKG.-50**

**HOLE SIZE-3/16"  
 HEAD DIAM.-33/64"  
 OVERALL HT.-19/32"**

**2257**



**WEATHERSTRIP CLIP  
 HONDA-BLACK NYLON  
 UNIT PKG.-100**

**2379**



(01553-00172); (90467-07050);  
 (90687-SA5-0030)  
**WEATHERSTRIP & TRIM PANEL CLIP  
 NISSAN, TOYOTA & HONDA  
 UNIT PKG.-25**

**HOLE SIZE-5 MM  
 HEAD DIAM.-13 MM  
 OVERALL HT.-17 MM**

**2414**



(20413107, 25016383)  
 (388246A; 6507557AA; 006516)  
**WEATHERSTRIP  
 & PANEL RETAINER  
 GM/FORD/CHRY/AMC  
 UNIT PKG.-50**

**HOLE SIZE-11/64"  
 HEAD DIAM.-7/16"  
 OVERALL HT.-23/32"**

**2618**



(HONDA-90664-671-0030)  
 (REPL.NISSAN-80833-S5000)  
**WEATHERSTRIP RETAINER  
 UNIT PKG.-25**

**HOLE SIZE-4 MM  
 HEAD SIZE-7 X 16 MM  
 OVERALL HT.-13 MM**

**2628**



(21077575), (4696129)  
**WEATHERSTRIP RETAINER  
 GM SATURN & CHRYSLER  
 UNIT PKG.-50**

**HOLE SIZE-4 MM; HEAD SIZE-7 X 17 MM  
 OVERALL HT.-14 MM**

**2652**



(20699808, 6502328)  
**WEATHERSTRIP RETAINER  
 GM & CHRYSLER  
 UNIT PKG.- 50**

**HOLE SIZE-5 MM  
 HEAD DIAM.-10 MM  
 OVERALL LENGTH-13 MM**

**2759**

(OE-20538173)



**WEATHERSTRIP RETAINER  
 CHEVY, BUICK, PONTIAC &  
 OLDSMOBILE- 1989 & UP  
 UNIT PKG.-50**

**HOLE SIZE-3/16"  
 HEAD DIAM.-7/16"  
 STEM-1/2" LONG**

**2766**



(73862-672-0030)  
**WEATHERSTRIP CLIP-HONDA  
 UNIT PKG.- 25**

**HOLE SIZE-5 MM  
 HEAD SIZE-7 X 16 MM**

**2844**

(N807438S, W704643)



(REPLACES-91568-SR2-003, 91530-SP1-003 )  
**WEATHERSTRIP RETAINER-FORD & HONDA  
 UNIT PKG.-100**

**HOLE SIZE-5 MM  
 HEAD SIZE-5 X 15 MM  
 STEM-10 MM**









**2845**

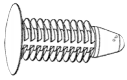

(10405030, 10283414)  
**WEATHERSTRIP RETAINER-GM  
 UNIT PKG.-50**

**HOLE SIZE-5.5 MM  
 HEAD SIZE-5 X 15 MM; STEM-7 MM**

## WEATHER STRIP CLIPS

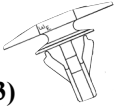
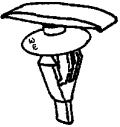
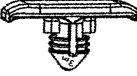
<p><b>2848</b></p>  <p>(CHRYSLER-4658673) (GM-10293674) <b>WEATHERSTRIP RETAINER GM &amp; CHRYSLER NEON</b></p> <p style="text-align: center;">UNIT PKG.- 50</p> <div style="border: 1px solid black; padding: 2px; width: fit-content; margin: 0 auto;"> <p>HOLE SIZE-5 MM HEAD DIAM.-10 MM STEM-16 MM</p> </div>	<p><b>2923</b></p>  <p>(OE #-N/A) <b>WEATHERSTRIP RETAINER CHRYSLER- LH, LHS 1997 &amp; UP</b></p> <p style="text-align: center;">UNIT PKG.-100</p> <div style="border: 1px solid black; padding: 2px; width: fit-content; margin: 0 auto;"> <p>HOLE SIZE-5 MM HEAD SIZE-6.5 X 16.5 MM</p> </div>	<p><b>2924</b></p>  <p>(OE #-N/A) <b>WEATHERSTRIP RETAINER CHRYSLER- LH, LHS 1997 &amp; UP</b></p> <p style="text-align: center;">UNIT PKG.-100</p> <div style="border: 1px solid black; padding: 2px; width: fit-content; margin: 0 auto;"> <p>HOLE SIZE-4.8 MM HEAD SIZE-6.5 X 11 MM</p> </div>
<p><b>2925</b></p>  <p>(OE #-N/A) <b>WEATHERSTRIP RETAINER CHRYSLER- LH, LHS 1997 &amp; UP</b></p> <p style="text-align: center;">UNIT PKG.-100</p> <div style="border: 1px solid black; padding: 2px; width: fit-content; margin: 0 auto;"> <p>HOLE SIZE-5.2 MM HEAD SIZE-6.5 X 16.5 MM</p> </div>	<p><b>2933</b></p>  <p>(OE #-N/A) <b>WEATHERSTRIP RETAINER LINCOLN/ FORD 1989 &amp; UP</b></p> <p style="text-align: center;">UNIT PKG.-50</p> <div style="border: 1px solid black; padding: 2px; width: fit-content; margin: 0 auto;"> <p>HOLE SIZE-5 MM HEAD SIZE-5 X 15 MM</p> </div>	<p><b>2990</b> (01553-09311)</p>  <p><b>WEATHERSTRIP CLIP NISSAN- ALTIMA &amp; SENTRA 1994 &amp; UP</b></p> <p style="text-align: center;">UNIT PKG.-25</p> <div style="border: 1px solid black; padding: 2px; width: fit-content; margin: 0 auto;"> <p>HOLE SIZE- 6 MM HEAD - 7 X 16 MM OVERALL LENGTH-13.5MM</p> </div>
<p><b>3011</b></p>  <p>(10169777) <b>WEATHERSTRIP CLIP GM-"W" BODIES '95 &amp; UP</b></p> <p style="text-align: center;">UNIT PKG.-25</p> <div style="border: 1px solid black; padding: 2px; width: fit-content; margin: 0 auto;"> <p>HOLE SIZE-5 MM HEAD DIAM.-11 MM OVERALL LENGTH-10 MM</p> </div>	<p><b>3014</b></p>  <p>(W708088-S300) <b>WEATHERSTRIP CLIP FORD-'96 &amp; UP</b></p> <p style="text-align: center;">UNIT PKG.-50</p> <div style="border: 1px solid black; padding: 2px; width: fit-content; margin: 0 auto;"> <p>HOLE SIZE-3/16" HEAD DIAM.-3/8" OVERALL LENGTH-23/32"</p> </div>	<p><b>3075</b> (91530-ST5-003) (REPL.-91516-SM4-003)</p>  <p><b>WEATHERSTRIP RETAINER HONDA- CIVIC DOORS-'95 &amp; UP ODYSSEY HOOD SEAL-'99 &amp; UP ACURA-'96 &amp; UP</b></p> <p style="text-align: center;">UNIT PKG.-10</p> <div style="border: 1px solid black; padding: 2px; width: fit-content; margin: 0 auto;"> <p>HOLE SIZE- 6 MM; HEAD - 5 X 15 MM OVERALL LENGTH-12 MM</p> </div>
<p><b>3100</b> (67867-12150) (REPLACES-67868-02020) <b>WEATHERSTRIP CLIP FRONT AND REAR DOORS TOYOTA-'90 &amp; UP LEXUS-'99 &amp; UP AVALON-'95 &amp; UP</b></p> <p style="text-align: center;">UNIT PKG.-25</p>  <div style="border: 1px solid black; padding: 2px; width: fit-content; margin: 0 auto;"> <p>HOLE SIZE- 6 MM HEAD - 5 X 15 MM OVERALL LENGTH-16 MM</p> </div>	<p><b>3103</b></p> <p>(OE #-N/A)</p> <p><b>WEATHERSTRIP RETAINER -VW</b></p> <p style="text-align: center;">UNIT PKG.-100</p>  <div style="border: 1px solid black; padding: 2px; width: fit-content; margin: 0 auto;"> <p>HOLE SIZE- 4 MM HEAD - 6 X 17 MM OVERALL LENGTH-9 MM</p> </div>	

## WEATHER STRIP CLIPS

**3104**



(OE #-N/A)  
**WEATHERSTRIP RETAINER-DOOR**  
**CHRYSLER PACIFICA**  
**2003 AND UP**  
**UNIT PKG.-100**

HOLE SIZE-3.3 MM  
 HEAD DIAM.-6 X 12 MM  
 OVERALL LENGTH-11 MM

**3105**

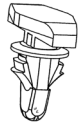

(OE #-N/A)  
**WEATHERSTRIP**  
**RETAINER- DOOR**  
**CHRYSLER, DODGE DURANGO**  
**2003 AND UP**  
**UNIT PKG.-50**

HOLE SIZE-5 MM  
 HEAD DIAM.-7 X 14 MM  
 OVERALL LENGTH-13 MM

**3106**

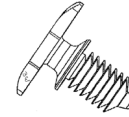

(OE #-N/A)  
**WEATHERSTRIP**  
**RETAINER- DOOR**  
**CHRYSLER SEBRING**  
**DODGE STRATUS-2003 & UP**  
**UNIT PKG.-50**

HOLE SIZE-5 MM  
 HEAD-5 X 15 MM  
 OVERALL HEIGHT- 15 MM

**3107**



(OE #-N/A)  
**WEATHERSTRIP RETAINER- DOOR**  
**FORD "S" SERIES TRUCKS,**  
**EXPLORER, & EXPLORER-SPORT**  
**MERCURY MOUNTAINEER**  
**1996 AND UP**  
  
**UNIT PKG.-100**

HOLE SIZE-5 MM  
 HEAD-5 X 14 MM  
 OVERALL HEIGHT-14 MM

**3166**

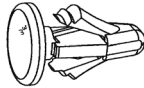

(OE #-N/A)  
**WEATHERSTRIP CLIP**  
**FORD F SERIES**  
**PICK UP- 2004 & UP**  
  
**UNIT PKG.-100**

HOLE SIZE-7 MM  
 HEAD-10 MM  
 OVERALL HT- 16 MM

**3167**



(OE #-N/A)  
**WEATHERSTRIP CLIP**  
**CHRYSLER 300 &**  
**DODGE MAGNUM-2005 & UP**  
**UNIT PKG.-100**

HOLE SIZE-6 MM  
 HEAD: 5 X 15 MM  
 OVERALL HT- 9 MM

**3175**

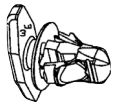

(OE #-N/A)  
**DOOR WEATHERSTRIP**  
**RETAINER**  
**ACURA, FORD, HONDA,**  
**& MITSUBISHI**  
  
**UNIT PKG.-100**

HOLE SIZE-5 MM  
 HEAD- 5 X 15 MM  
 OVERALL HT- 11.5 MM

**3178**

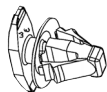

(OE #-N/A)  
**WEATHERSTRIP**  
**RETAINER**  
**DOOR & HOOD SEALS**  
**FORD/LINCOLN**  
  
**UNIT PKG.-100**

HOLE SIZE-5.3 MM  
 HEAD-5 X 15 MM  
 OVERALL HT- 12.5 MM

**3179**



(OE #-N/A)  
**WEATHERSTRIP**  
**RETAINER**  
**DOOR & HOOD SEALS**  
**JEEP, CHRYSLER NEON,**  
**STRATUS, SEBRING**  
  
**UNIT PKG.-100**

HOLE SIZE-6 MM  
 HEAD-5 X 15 MM  
 OVERALL HT- 11.6 MM



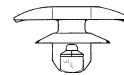





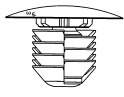
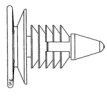

**3303**



(90467-04034)  
**DOOR WEATHERSTRIP**  
**RETAINER**  
**TOYOTA/ LEXUS**  
**2008 & UP**  
  
**UNIT PKG.- 50**

FOR 5 MM HOLE SIZE  
 5 X 15 MM TOP HEAD  
 9 MM OVERALL HEIGHT

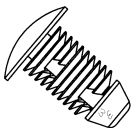
## WEATHER STRIP/ HOOD SEAL CLIPS

<p><b>3239</b></p>  <p>(OE #-N/A)  <b>WEATHERSTRIP RETAINER</b>  <b>GM TRUCKS/ LIGHT TRUCKS</b>  <b>2007 AND UP</b>  <b>UNIT PKG.- 50</b></p> <div style="border: 1px solid black; padding: 2px; margin-top: 5px;"> <p>HOLE SIZE-8 MM              HEAD DIAM.-16 MM              OVERALL HEIGHT-11 MM</p> </div>	<p><b>3240</b></p>  <p>(OE #-N/A)  <b>WEATHERSTRIP RETAINER</b>  <b>GM TRUCKS/ LIGHT TRUCKS</b>  <b>2000 AND UP</b>  <b>UNIT PKG.- 50</b></p> <div style="border: 1px solid black; padding: 2px; margin-top: 5px;"> <p>HOLE SIZE-5 MM              HEAD DIAM.-11 MM              OVERALL HEIGHT-13 MM</p> </div>	<p><b>2971</b></p>  <p>(91502-S84-A11)  <b>HOOD SEAL CLIP</b>  <b>HONDA- ACCORD &amp; ODYSSEY</b>  <b>'98 &amp; UP</b>  <b>UNIT PKG.-15</b></p> <div style="border: 1px solid black; padding: 2px; margin-top: 5px;"> <p>HOLE SIZE-6 MM              HEAD DIAM.-6 X 16 MM,              OVERALL LENGTH-16 MM</p> </div>
<p><b>2523</b></p>  <p>(90467-08004; 90467-08011)              (90467-A0009; 90080-46010)  <b>PANEL /HOOD SEAL CLIP</b>  <b>TOYOTA</b>  <b>UNIT PKG.-25</b></p> <div style="border: 1px solid black; padding: 2px; margin-top: 5px;"> <p>HOLE SIZE-5 MM              HD. DIAM.-13 MM</p> </div>	<p><b>2687</b></p>  <p>(91520-SM4-C010)              (SUB FOR 91518-S10-003)  <b>RETAINER-HOOD &amp; OTHERS</b>  <b>ACURA/HONDA-ODYSSEY</b>  <b>UNIT PKG.-25</b></p> <div style="border: 1px solid black; padding: 2px; margin-top: 5px;"> <p>HOLE SIZE-6 MM              HEAD DIAM.-10 MM              STEM-10 MM</p> </div>	<p><b>2961</b></p>  <p>(90467-06161-01)  <b>RETAINING CLIP</b>  <b>TOYOTA</b>  <b>UNIT PKG.-25</b></p> <div style="border: 1px solid black; padding: 2px; margin-top: 5px;"> <p>HOLE SIZE-5 MM; HD. DIAM.-14 MM              STEM-10 MM              PANEL THICKNESS-3 MM</p> </div>
<p><b>2964</b></p>  <p>(HONDA-66435-648-000F)              (REPLACES-              NISSAN-01553-00291)  <b>RETAINING CLIP</b>  <b>HONDA, NISSAN</b>  <b>UNIT PKG.-50</b></p> <div style="border: 1px solid black; padding: 2px; margin-top: 5px;"> <p>HOLE SIZE-5.5 MM              HD. DIAM.-11 MM              STEM-15 MM</p> </div>	<p><b>2966</b></p>  <p>(91518-SM4-003)  <b>RETAINER-HOOD &amp; TRUNK</b>  <b>MOULDING</b>  <b>ACURA/HONDA</b>  <b>CIVIC-'94 &amp; UP</b>  <b>UNIT PKG.-15</b></p> <div style="border: 1px solid black; padding: 2px; margin-top: 5px;"> <p>HOLE SIZE-6 MM              HEAD DIAM.-12 MM              STEM-9 MM</p> </div>	<p><b>3336</b></p>  <p>(90467-08136)  <b>PLASTIC RETAINER FENDER</b>  <b>SEAL, RADIATOR SPLASH</b>  <b>SHIELD &amp; INT. DOOR TRIM</b>  <b>TOYOTA/LEXUS-'07 &amp; UP</b>  <b>UNIT PKG.-25</b></p> <div style="border: 1px solid black; padding: 2px; margin-top: 5px;"> <p>HOLE SIZE-7 MM              HEAD DIAM.-20 MM              STEM LENGTH-9 MM</p> </div>
<p><b>3094</b></p> <p>(65810-K2000)</p>  <p><b>HOOD SEAL RETAINER</b>  <b>NISSAN MAXIMA-2000 &amp; UP</b>  <b>INFINITY-QX4; M45- '97&amp;UP</b>  <b>UNIT PKG.-25</b></p> <div style="border: 1px solid black; padding: 2px; margin-top: 5px;"> <p>HOLE SIZE-5 MM              HEAD-7 X 16 MM              OVERALL HT- 11.5 MM</p> </div>	<p><b>3205</b></p> <p>(GM-10293193),              (FORD-N811040-S)</p>  <p><b>PLASTIC RETAINER</b>  <b>HOOD SEAL, WEATHERSTRIP,</b>  <b>INSTRUMENT PANEL &amp; INSULATION</b>  <b>GM-2005 &amp; UP; CHEVY COBALT;</b>  <b>PONTIAC; FORD-MUSTANG</b>  <b>UNIT PKG.-50</b></p> <div style="border: 1px solid black; padding: 2px; margin-top: 5px;"> <p>HOLE SIZE-7 MM; HD DIAM. 13 MM              OVERALL HT.-18 MM</p> </div>	<p><b>3341</b></p>  <p>(BP4K-58-762)  <b>PLASTIC WEATHERSTRIP</b>  <b>RETAINER</b>  <b>MAZDA-'04 &amp; UP</b>  <b>UNIT PKG.-25</b></p> <div style="border: 1px solid black; padding: 2px; margin-top: 5px;"> <p>FOR 4 MM HOLE; 9 MM HD DIAM.;              7 MM STEM LENGTH</p> </div>

## RETAINERS HOOD INSULATION, COWL

**1222**

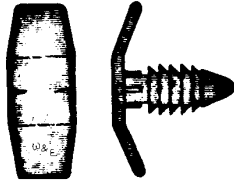

(383927-S, 384051-S), (480534)  
**RETAINER CLIP-COWL TO HOOD  
 INSULATION & SPLASH SHIELD  
 FORD AND GM  
 UNIT PKG.-50**

HOLE-1/4"  
 HD DIAM.-1" X 0.4"  
 OVERALL HT-23/32"

**1223**



(1609141, 2998430)  
**RETAINER-UNIVERSAL TRIM  
 & PANEL CLIP, UPPER GRILLE  
 CHRYSLER  
 UNIT PKG.-25**

HOLE SIZE-1/4"  
 HEAD DIAM.-1.25"

**1224**

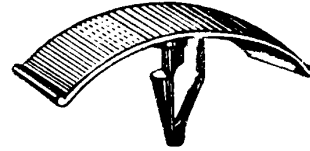

(OE-385330-S), (6003351)  
**HOOD INSULATION CLIP  
 FORD & CHRYSLER-'73 & UP  
 UNIT PKG.-50**

HOLE SIZE-1/4"  
 HEAD SIZE-1/2" X 5/8"

**2230**

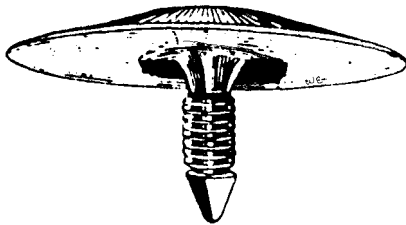

(3078511, REPLACES 3977775)  
**HOOD INSULATION CLIP-GM AND UNIVERSAL  
 UNIT PKG.-50**

HOLE SIZE-1/4"; HEAD DIAM.-2"; STEM-3/4"

**2425**

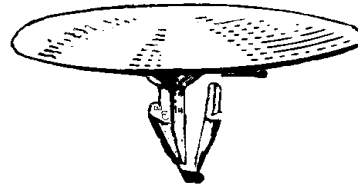

(OE 388908-S)  
**HOOD INSULATION CLIP  
 FORD- '79 & UP  
 UNIT PKG.-50**

HOLE SIZE-6 MM  
 HEAD DIAM.-45 MM  
 OVERALL HEIGHT-21 MM

**2493**

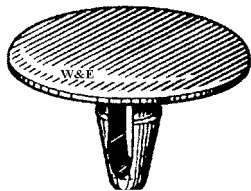

(90467-09008)  
**HOOD INSULATION CLIP  
 TOYOTA  
 UNIT PKG.-20**

HOLE SIZE-7 MM  
 HEAD DIAM.-30 MM

**2583**

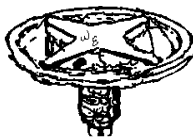

(65846-30FOO)  
 (SUB FOR 65832-F5000)  
**HOOD INSULATION CLIP  
 NISSAN- '81 & UP  
 UNIT PKG.-25**

HOLE SIZE- 5 MM  
 HEAD DIAM.-30 MM



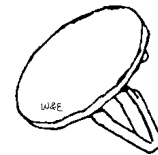



**2656**

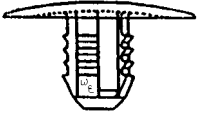

(6502842), (21039129)  
**HOOD INSULATION RETAINER  
 CHRYSLER- LH & NS MINIVANS  
 GM-SATURN  
 UNIT PKG.-50**

HOLE SIZE- 1/4"  
 HEAD DIAM.-1-3/16"

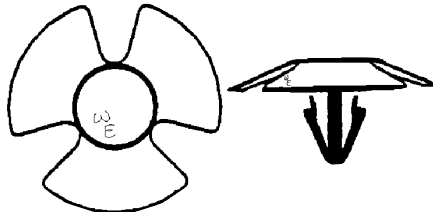
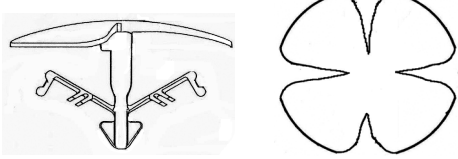
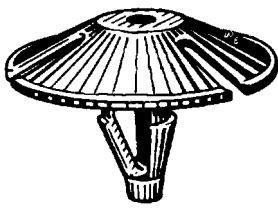
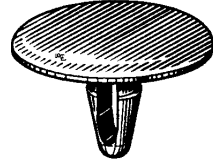
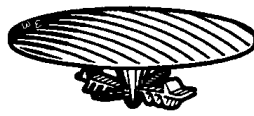
## RETAINERS- HOOD INSULATION

<p><b>2678</b></p>  <p>(W700671S300) HOOD INSULATION RETAINER FORD CONTOUR, MYSTIQUE &amp; FOCUS</p> <div style="border: 1px solid black; padding: 2px; width: fit-content; margin: 5px auto;"> <p>HOLE SIZE- 8 MM HEAD DIAM.-25 MM</p> </div>	<p><b>2752</b></p>  <p>(6503274); (6503971); (52009077); (J3081054) RETAINER- HOOD INSULATION, CARPET, &amp; WIRE HARNESS- CHRYSLER UNIT PKG.- 25</p>	<p><b>2801</b></p>  <p>(11609690;6504098; N808842-S;W705002-S300) HOOD INSULATION CLIP GM, CHRYSLER &amp; FORD '96 &amp; UP</p> <div style="border: 1px solid black; padding: 2px; width: fit-content; margin: 5px auto;"> <p>HOLE SIZE-1/4" HD. DIAM.-1-1/4" OVERALL HT.-.25/32"</p> </div>	<p><b>2967</b></p>  <p>(65846-40F00;65846-4Z- 000) HOOD INSULATION RETAINER NISSAN- '89 &amp; UP NIT PKG.-15</p> <div style="border: 1px solid black; padding: 2px; width: fit-content; margin: 5px auto;"> <p>HOLE SIZE-5 MM HEAD DIAM.-.28 MM OVERALL HEIGHT-11MM</p> </div>
<p><b>2913</b></p>  <p>(90467-09050, 90467-A0003) PLASTIC HOOD INSULATION RETAINER TOYOTA CAMRY &amp; SOLARA- LEXUS-'98 &amp; UP</p> <p style="text-align: center;">UNIT PKG.-15</p> <div style="border: 1px solid black; padding: 2px; width: fit-content; margin: 5px auto;"> <p>HOLE SIZE-7 MM HEAD DIAM.-25 MM STEM-10 MM</p> </div>	<p><b>2927</b></p>  <p>(4878883AA) HOOD INSULATION RETAINER CHRYSLER- LH, LHS '97 &amp; UP</p> <p style="text-align: center;">UNIT PKG.-50</p> <div style="border: 1px solid black; padding: 2px; width: fit-content; margin: 5px auto;"> <p>HOLE SIZE-6.35 MM (1/4") HEAD DIAM.-30 MM</p> </div>	<p><b>3374</b></p>  <p>(91501-SWA-003) HOOD INSULATION RETAINER HONDA-ACCORD, CR-V, CIVIC &amp; INSIGHT; ACURA-RDX, ILX &amp; TSX- 2012-UP</p> <p style="text-align: center;">UNIT PKG.-25</p> <div style="border: 1px solid black; padding: 2px; width: fit-content; margin: 5px auto;"> <p>HOLE SIZE-7 MM HEAD DIAM.-30 MM O/A HEIGHT-18 MM</p> </div>	
<p><b>2957</b></p>  <p>(4341060) HOOD INSULATION &amp; FENDER SHIELD RETAINER- CHRYSLER '85 &amp; UP</p> <p style="text-align: center;">UNIT PKG.-25</p>	<p><b>2972</b></p>  <p>(90467-09006) HOOD INSULATION CLIP TOYOTA- AVALON, &amp; CAMRY; LEXUS-'88 &amp; UP</p> <p style="text-align: center;">UNIT PKG.-10</p> <div style="border: 1px solid black; padding: 2px; width: fit-content; margin: 5px auto;"> <p>HOLE SIZE-6 MM HEAD DIAM.-30 MM OVERALL LENGTH-20 MM</p> </div>	<p><b>2973</b></p>  <p>(90700-SJ4-000) HOOD INSULATION CLIP; HONDA ACCORD &amp; ACURA LEGEND '91 &amp; UP</p> <p style="text-align: center;">UNIT PKG.-15</p> <div style="border: 1px solid black; padding: 2px; width: fit-content; margin: 5px auto;"> <p>HEAD DIAM.-30 MM O/A LENGTH-12 MM</p> </div>	<p><b>2983</b></p>  <p>(20064875) PLASTIC INSULATION HOOD RETAINER GM-'80 &amp; UP</p> <p style="text-align: center;">UNIT PKG.-25</p> <div style="border: 1px solid black; padding: 2px; width: fit-content; margin: 5px auto;"> <p>HOLE SIZE-1/4"; HEAD DIAM.-1-5/8"; STEM-3/4"</p> </div>



## RETAINERS- HOOD INSULATION, TRIM PANEL

**2993**

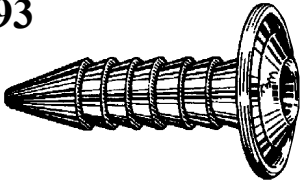

(GM 7642589), (AMC 4001934),  
(FORD W709883-S300)  
FIREWALL INSULATION  
RETAINER-GM, AMC, FORD  
UNIT PKG.-25

HOLE SIZE-3/8";  
HEAD DIAM.-1"; STEM-1.3"

**3083**

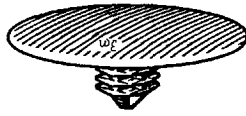

(90700-SB2-003)  
PLASTIC RETAINER  
HOOD INSULATION  
HONDA-PRELUDE-'85 & UP  
INSIGHT-'00 & UP  
ACURA-'96 & UP  
UNIT PKG.-15

HOLE SIZE-6 MM  
HEAD DIAM.-30 MM,  
OVERALL HEIGHT-11 MM

**3058**

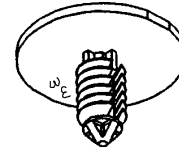

(6504135)  
HOOD INSULATION CLIP  
CHRYSLER MINIVANS &  
DODGE DURANGO  
'97 & UP  
UNIT PKG.-50

HOLE SIZE-1/4"  
HEAD DIAM.-1"

**3119**

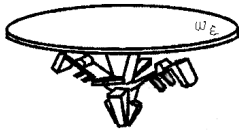

(91501-S1K-0030; 91501-STK-0030)  
HOOD INSULATION CLIP  
HONDA-ACCORD, CIVIC  
CRV, ACURA-2000 & UP

UNIT PKG.-25

HOLE SIZE- 7 MM  
HEAD DIAM.-30 MM  
OVERALL HT.- 16 MM

**3231**



(81126-37010)  
HOOD INSULATION  
RETAINER  
KIA & HYUNDAI  
1996 & UP  
UNIT PKG.-25

HOLE SIZE-8 MM  
HEAD DIAM.-26 MM  
OVERALL HEIGHT- 16 MM

**3208**

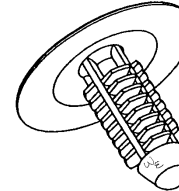

(22718305, N-802734S, 6506788)  
BLACK PLASTIC RETAINER  
HOOD INSULATION, FENDER APRON,  
FRONT BUMPER COVER &  
INTERIOR TRIM PANEL  
GM, FORD, CHRYSLER '83 & UP  
UNIT PKG.-50

HOLE SIZE-7 MM  
HEAD DIAM.-25 MM  
OVERALL HT.-26 MM

**3305**

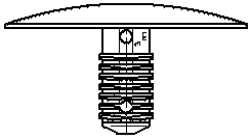

(90913-0074, 91501-TA0-0000)  
PLASTIC RETAINER  
HOOD INSULATION  
HONDA, SUBARU  
2008 & UP  
UNIT PKG.-15

HOLE SIZE-7 MM  
HEAD DIAM- 30 MM  
OVERALL HEIGHT-16 MM

**3342**

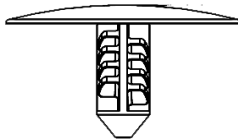

(11571159)  
PLASTIC HOOD  
INSULATION RETAINER  
GM-CHEVY CRUZE, EQUINOX,  
& VOLT-GMC-TERRAIN  
2010-UP

UNIT PKG.-25

HOLE SIZE-7 MM  
HEAD DIAM- 30 MM  
STEM LENGTH-15 MM

**3363**







(90814-FC001)  
PLASTIC HOOD  
INSULATION RETAINER  
SUBARU-B9 TRIBECA, IMPREZA,  
FORESTER & LEGACY OUTBACK  
2009-UP

UNIT PKG.-10

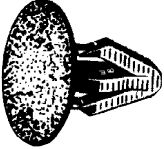
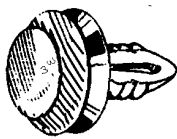
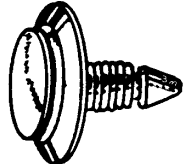
HOLE SIZE-9 MM  
HEAD DIAM- 30 MM  
STEM LENGTH-13 MM

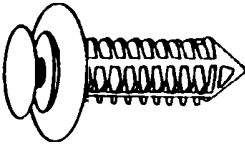
## PLASTIC RETAINERS-INTERIOR TRIM PANEL

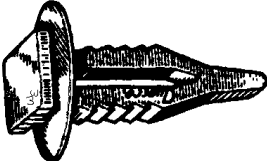
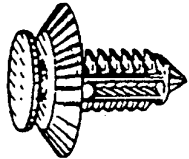
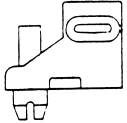
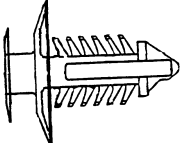
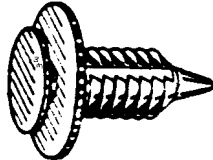
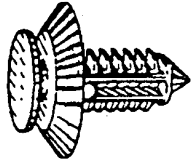
<p><b>2278</b></p>  <p>(REPLACES 01553-00051)  <b>TRIM PANEL RETAINER</b>            BLACK PLASTIC            TOYOTA &amp; DATSUN            UNIT PKG.-25</p>	<p><b>2363</b></p>  <p>(387477-S)  <b>INTERIOR TRIM PANEL CLIP</b>            FORD-ALL MODELS-'77 &amp; UP            UNIT PKG.-50</p>	<p><b>2364</b></p>  <p>(N802900, N801925-S)  <b>TRIM PANEL CLIP</b>            FORD-ALL MODELS-'80 &amp; UP            UNIT PKG.-25</p> <div style="border: 1px solid black; padding: 2px; text-align: center; font-size: small;">             FOR 1/4" HOLE; 1/2" TOP HD DIAM.           </div>
<p><b>2373</b></p>  <p>(90687-671-0030)  <b>INTERIOR PANEL FASTENER</b>            HONDA            UNIT PKG.- 10</p> <div style="border: 1px solid black; padding: 2px; text-align: center; font-size: small;">             10 MM HOLE; 20 MM HD DIAM.              OVERALL LENGTH-23 MM           </div>	<p><b>2455</b></p>  <p>(FORD-N805612-S)            (GM-10143422)            (CHRYSLER- 34202599)            (AMC- 893202-599)  <b>DOOR PANEL FASTENER</b>            FORD, GM, CHRYSLER            JEEP EAGLE, PREMIER -'88 &amp; UP            UNIT PKG.-25</p>	<p><b>2492</b></p>  <p>(89421-76980), (76906-T3000)            (90467-09069-06:-20,-21), (9926-40-658)  <b>INTERIOR PANEL FASTENER</b>            ISUZU, NISSAN, TOYOTA, MAZDA            UNIT PKG.-20</p> <div style="border: 1px solid black; padding: 2px; text-align: center; font-size: small;">             HOLE SIZE-7 MM              HEAD DIAM.-14 MM              OVERALL LENGTH-19 MM           </div>
<p><b>2504</b></p>  <p>(10093200,20036949)  <b>TRIM PANEL RETAINER</b>            GM-"A" BODY- '76 &amp; UP            UNIT PKG.-25</p>	<p><b>2561</b></p>  <p>(21042058, 21042045)            (21042104, 21042053)  <b>DOOR TRIM PANEL RETAINER</b>            GM SATURN-'91 &amp; UP            UNIT PKG.-50</p> <div style="border: 1px solid black; padding: 2px; text-align: center; font-size: small;">             HOLE SIZE-8 MM              OVERALL LENGTH-24 MM           </div>	<p><b>2677</b></p>  <p>(W701430S300)  <b>DOOR TRIM RETAINER</b>            FORD- CONTOUR &amp; MYSTIQUE            UNIT PKG.-25</p> <div style="border: 1px solid black; padding: 2px; text-align: center; font-size: small;">             HOLE SIZE-7 MM           </div>
<p><b>2706</b></p>  <p>(01553-S3500)  <b>DOOR TRIM PANEL RETAINER</b>            NISSAN TRUCKS            UNIT PKG.-50</p> <div style="border: 1px solid black; padding: 2px; text-align: center; font-size: small;">             HOLE SIZE-8 MM              OVERALL LENGTH-21 MM           </div>	<p><b>2760</b></p>  <p>(6503709); (REPLACES FORD-N805155S)  <b>TRIM PANEL CLIP</b>            FORD, DODGE            '94 &amp; UP            UNIT PKG.-50</p> <div style="border: 1px solid black; padding: 2px; text-align: center; font-size: small;">             HOLE SIZE-9/32", STEM-3/4"           </div>	<p><b>2785</b></p>  <p>(F58B16237A02AB)  <b>DOOR TRIM PANEL CLIP</b>            FORD WINDSTAR-95 &amp; UP            UNIT PKG.-25</p> <div style="border: 1px solid black; padding: 2px; text-align: center; font-size: small;">             HOLE SIZE-8 MM              OVERALL LENGTH-24 MM           </div>

## PLASTIC RETAINERS-INTERIOR / EXTERIOR

**3203**

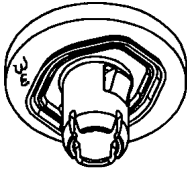

(22722860)  
**DOOR TRIM PANEL GROMMET**  
 GM-VARIOUS MODELS 2002 & UP  
 (USE WITH W&E #3218)

**UNIT PKG.-25**

HOLE SIZE- 9 MM  
 FLANGE- 24 MM

**3218**

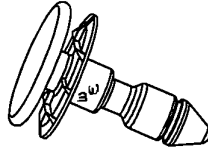

(11561499; REPL. 22722859 & 10363811)  
**DOOR PANEL RETAINER PIN**  
 (USE WITH W&E #3203)  
 OLDS, CADILLAC, CHEVY, PONTIAC  
 GM- 2002 & UP

**UNIT PKG.-25**

HEAD DIAM.-20 MM  
 OVERALL LENGTH- 28 MM

**3010**

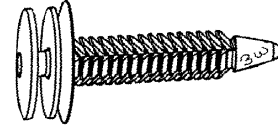

(10421018)  
**DOOR TRIM PANEL CLIP**  
 GM-'97 & UP

**UNIT PKG.-25**

HOLE SIZE-7 MM  
 TOP HEAD DIAM.18 MM  
 OVERALL LENGTH- 41 MM

**1225**



(14093311), (332364), (20732399)  
 (389358S), (6031321), (3691590)  
**SCREW NAIL RETAINER**  
**BLACK**  
 GM, AMC & UNIVERSAL

**UNIT PKG.-50**

HOLE SIZE-1/4"  
 HEAD DIAM.-45/64"  
 STEM LENGTH-5/8"

**2107**

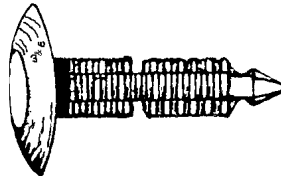

(15552345, 1699250)  
 (REPLACES:GM-14074081)  
**INTERIOR TRIM RETAINER**  
 GM & UNIVERSAL

**UNIT PKG.-25**

FOR 7 MM HOLE  
 HEAD DIAM.-19 MM  
 OVERALL LENGTH- 34.5 MM

**2108**

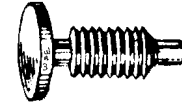

(411700)  
**RETAINER- FLEXIBLE**  
**FILLER BETWEEN**  
**IMPACT BUMPER**  
**& FENDER- BLACK**  
 GM & UNIVERSAL  
**UNIT PKG.-100**

HOLE SIZE-1/4"  
 HEAD DIAM.-1/2"  
 OVERALL HEIGHT-13/16"

**2140**

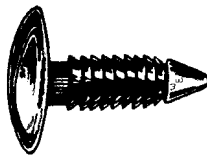

(GM-1605396), (FORD-388577S, W705589S)  
 (CHRYSLER-6030441, 3691590), (AMC-4004919, 4004569)  
**SCREW NAIL RETAINER-YOKE SHIELD TO SUPPORT**  
**MOULDING, FENDERS, ETC.**  
 (1/4" LONGER THAN W&E #1225)  
 GM, CHRYSLER, FORD & AMC

**UNIT PKG.-50**

HOLE SIZE-1/4"  
 HEAD DIAM.-45/64"  
 STEM-13/16"

**2204**

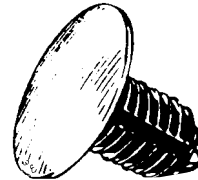

(1619321)  
**PANEL FASTENER-**  
**RADIATOR SKIRT ATTACHING**  
**CADILLAC & GM**

**UNIT PKG.-25**

HOLE SIZE-13/32"; HD DIAM.-1"  
 STEM LENGTH -13/16"

## PLASTIC RETAINERS-INTERIOR / EXTERIOR

**2279**



(OE-6270163)  
**SCREW NAIL RETAINER  
 GREY**  
 GM, AMC & UNIVERSAL  
 UNIT PKG.-50

HOLE SIZE-1/4"  
 HD DIAM.-45/64"  
 STEM-5/8"

**2299**

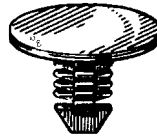

(FORD-387258-S)  
 (GM-20032850, 15676621)  
 (CHRYSLER-3861577)  
**RETAINER- MUD SHIELD, DOOR  
 SOUND ABSORBER, DUSTSHIELD**  
 UNIT PKG.- 50

HOLE SIZE-1/4"  
 HEAD DIAM.-3/4"  
 STEM LENGTH-1/2"

**2347**

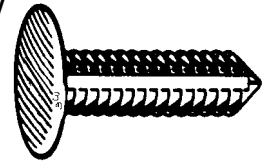

(10185925)  
**INTERIOR TRIM CLIP- BLACK**  
 GM, FORD & UNIVERSAL

UNIT PKG.-25

HOLE SIZE-7 MM  
 HD. DIAM.-20 MM  
 GRIP RANGE-30 MM

**2356**



(34202787), (1631564), (N804379S)  
**BUMPER FASCIA RETAINER**  
 GM, FORD, AMC, CHRYSLER  
 '85 & UP  
 UNIT PKG.-25

HOLE SIZE-10 MM  
 HEAD DIAM.-21 MM  
 STEM LENGTH-28MM

**2365**

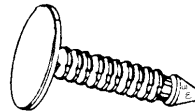

(20514862)  
**GRILLE RETAINER**  
 GM- "N" BODY- '85 & UP

UNIT PKG.-100

HOLE SIZE-1/8"  
 HEAD DIAM.-15/64"  
 OVERALL HEIGHT-51/64"

**2367**

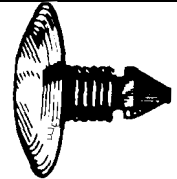

CHRYSLER- (6003349, 6003423)  
 GM- (2088248, 15599064)  
 FORD- (385661S)  
 VW-(N989022)  
**INTERIOR TRIM PANEL CLIP**  
 CHRYSLER, GM, FORD, VW  
 UNIT PKG.-50

FOR 7 MM HOLE  
 24 MM HEAD DIAMETER  
 OVERALL LENGTH 21 MM

**2407**

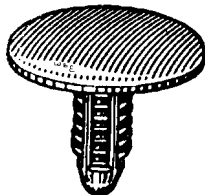

(6501067)  
**PANEL FASTENER**  
 FASCIA & GENERAL USE  
 CHRYSLER-'84 & UP

UNIT PKG.-50

FOR 1/4" HOLE; 1" HD DIAM.  
 STEM LENGTH-49/64"

**2418**

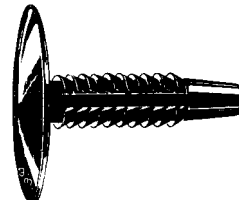

(OE-388930-S)  
 (SUB FOR 391039-S)  
**TRIM PANEL RETAINER**  
 FORD- 1980 & UP

UNIT PKG.-50

FOR 1/4" HOLE; HD DIAM.-1"  
 STEM LENGTH-13/16"

**2459**

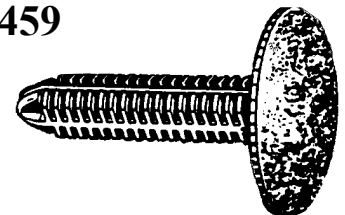

(FORD-N804349S)  
 (GM-22575287)  
 (CHRYSLER-6502586)  
**INTERIOR TRIM RETAINER**  
 FORD, GM & CHRYSLER

UNIT PKG.-25

HOLE SIZE-7 MM  
 GRIP RANGE-30 MM

## PLASTIC RETAINERS-INTERIOR / EXTERIOR

**2461**  
(389443-S)

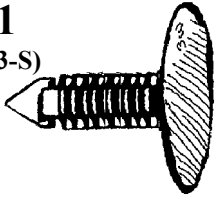

**BUMPER FASCIA CLIP**  
FORD- '81 & UP  
UNIT PKG.-25

1/4" HOLE; 1" HD. DIAM.  
1-1/16" STEM LENGTH

**2512**  
(22512276)

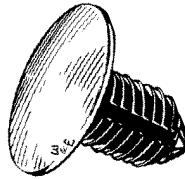

**DOOR PANEL/BUMPER STRIP CLIP**  
GM-'80 & UP  
UNIT PKG.-50

HOLE SIZE-10 MM; HEAD SIZE-.22 MM  
OVERALL HEIGHT-24 MM

**2629**

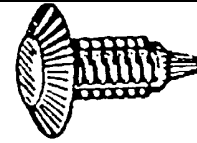

(21094146, 21110201), (6501301)  
**TRIM PANEL & WHEEL  
WELL RETAINER**  
GM SATURN- '91 & UP  
CHRYSLER VANS-'87 & UP  
UNIT PKG.-25

5/16" HOLE; 3/4" HEAD DIAM. ;7/8" STEM L.

**2643**

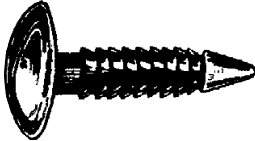

(10077401, 10121502; W709346-S300)  
**PLASTIC SHIELD CLIP**  
(LONGER THAN W & E #2140)  
GM, FORD & UNIVERSAL

UNIT PKG.-50

HOLE SIZE-1/4"; HD. DIAM.-11/16"  
STEM-1-1/16"

**2644**

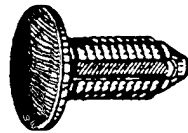

(CHRY.-650403)  
(FORD-N807721-S)  
**TRIM PANEL CLIP**  
FORD-'93 & UP  
CHRYSLER-'95 & UP

UNIT PKG.-50

HOLE SIZE-5/16"  
HD. DIAM.-5/8"  
STEM-3/4"

**2680**

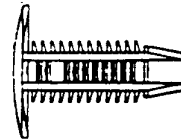

(W7013805SW)  
**PLASTIC RETAINER**  
TRUNK LINER, RADIATOR  
SHIELD, & CARPET  
FORD- CONTOUR & MYSTIQUE

UNIT PKG.-25

HOLE SIZE-7 MM  
HEAD DIAM.-18 MM  
STEM-22 MM

**2861**



(10063599)  
**PLASTIC RETAINER**  
REMOTE CONTROL  
DOOR LOCK  
RECEIVER AND UNIVERSAL  
UNIT PKG.-100

HOLE SIZE-4 MM;  
HEAD DIAM.-9MM  
PANEL RANGE-0.8-6 MM

**2863**

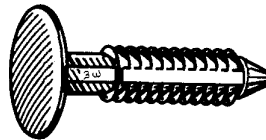

(10146315)  
**BUMPER FASCIA RETAINER**  
GM "U" VAN (APV) -'94 & UP

UNIT PKG.-50

HOLE SIZE-1/4"  
HEAD DIAM.-11/16"  
OVERALL STEM-1-1/4"

**2900**

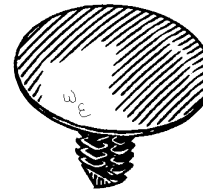

(FORD-388904S)  
(CHRYSLER-4381385, 6501086)  
**BUMPER COVER RETAINER**  
DOOR FRAME SPACER; BLACK

UNIT PKG.-50

HOLE SIZE-1/4"  
HD. DIAM.-1"; STEM-13/16"

**2952**  
(10185866)





**PLASTIC CLIP-HEADLAMP TRIM**  
GM C, K TRUCKS-'99 & UP

UNIT PKG.-25

HOLE SIZE-7 MM  
HD. DIAM.-14 MM; STEM-30 MM

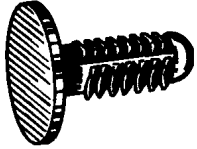
## PLASTIC RETAINERS-INTERIOR / EXTERIOR

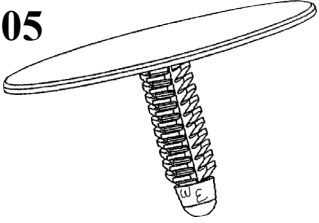
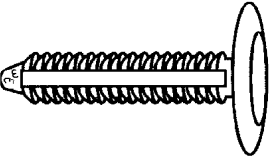
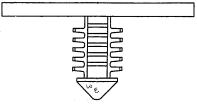
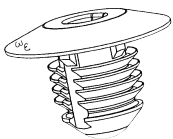
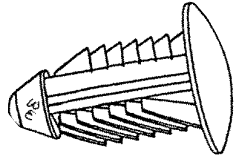
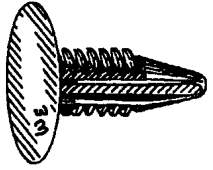
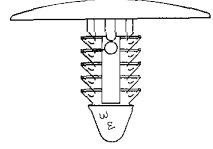
<p><b>2976</b></p>  <p>(25601491)  <b>BUMPER COVER RETAINER</b>            DOOR TRIM, RADIATOR BAFFLE            GM- "H" BODY-'92 &amp; UP</p> <p style="text-align: center;">UNIT PKG.-50</p> <div style="border: 1px solid black; padding: 2px; text-align: center; font-size: small;">             HOLE SIZE-7 MM              HEAD DIAM.-19 MM           </div>	<p><b>2992</b></p>  <p>(W707889-S300)  <b>MUD FLAP RETAINER</b>            FORD EXPEDITION &amp; F-150            SERIES- 1997 &amp; UP</p> <p style="text-align: center;">UNIT PKG.-25</p> <div style="border: 1px solid black; padding: 2px; text-align: center; font-size: small;">             HOLE SIZE-1/4"; HD DIAM.-11/16";              STEM-1-3/4"           </div>	<p><b>3005</b></p>  <p>(FORD-N803387-S300)  <b>TRIM PANEL CLIP</b></p> <p style="text-align: center;">UNIT PKG.-25</p> <div style="border: 1px solid black; padding: 2px; text-align: center; font-size: small;">             HOLE SIZE-1/4"; HD. DIAM.-1-3/4"              STEM LENGTH-1"           </div>
<p><b>3006</b></p>  <p>(W701855-S300)  <b>RETAINER-MUD FLAP</b>  <b>AND FENDER LINER</b>            FORD EXPLORER &amp;            MOUNTAINEER-2002</p> <p style="text-align: center;">UNIT PKG.-25</p> <div style="border: 1px solid black; padding: 2px; text-align: center; font-size: small;">             HOLE SIZE-6MM              HD. DIAM.-22 MM              STEM LENGTH-35 MM           </div>	<p><b>3007</b></p>  <p>(4696963)  <b>HEADLINER CLIP</b>            CHRYSLER CIRRUS, STRATUS            AND VANS-'95 &amp; UP</p> <p style="text-align: center;">UNIT PKG.-25</p> <div style="border: 1px solid black; padding: 2px; text-align: center; font-size: small;">             HOLE SIZE-6 MM              HD. DIAM.-27 MM              OVERALL LENGTH-13 MM           </div>	<p><b>3008</b></p>  <p>(GM-15056810)  <b>(CHRY.-6505686AA)</b>  <b>RETAINER-BUMPER FASCIA</b>            GM-S/T TRUCKS-2002            CHRYSLER-2000 &amp; UP</p> <p style="text-align: center;">UNIT PKG.-25</p> <div style="border: 1px solid black; padding: 2px; text-align: center; font-size: small;">             HOLE SIZE-12.5 MM              HD. DIAM.-25 MM              OVERALL LENGTH-19 MM           </div>
<p><b>3009</b></p>  <p>(11518201), (25665391)  <b>RETAINER-BUMPER FASCIA</b>            GM-"N" BODIES-'99 &amp; UP</p> <p style="text-align: center;">UNIT PKG.-25</p> <div style="border: 1px solid black; padding: 2px; text-align: center; font-size: small;">             HOLE SIZE-10.5 MM              HD. DIAM.-21.5 MM              OVERALL LENGTH-32 MM           </div>	<p><b>3056</b></p>  <p>(20319841)  <b>RETAINER-SEAT BACK</b>  <b>BLACK</b>            GM-CAMARO, FIREBIRD            CHEVY S&amp;T TRUCKS</p> <p style="text-align: center;">1982 &amp; UP            UNIT PKG.-25</p> <div style="border: 1px solid black; padding: 2px; text-align: center; font-size: small;">             HOLE SIZE-1/4"              HD. DIAM.-13/16"              STEM LENGTH-1"           </div>	<p><b>3064</b></p>  <p>(16674629), (6503943),            (N806113-S)  <b>INTERIOR TRIM PANEL</b>  <b>RETAINER</b></p> <p style="text-align: center;">GM, CHRYSLER &amp; FORD            UNIT PKG.-50</p> <div style="border: 1px solid black; padding: 2px; text-align: center; font-size: small;">             HOLE SIZE-1/4"              HEAD O.D.-1"              STEM LENGTH-5/8"           </div>

# PLASTIC RETAINERS/COWL TRIM-INTERIOR / EXTERIOR

**3097**

(GM 10182300)  
(CHRY 6033018)  
(FORD N803678-S)

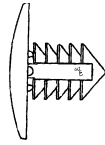

PLASTIC RETAINER  
FRONT BUMPER, FENDER,  
TRIM PANELS, SEAT, & CARPET  
BLACK  
GM, CHRYSLER, FORD  
UNIT PKG.-50

HOLE SIZE-6.3 MM  
HEAD DIAM.-18.5 MM; STEM-11 MM

**3098**

(CHRY 6505417AA)  
(FORD W709154S300)  
PLASTIC TRIM PANEL  
RETAINER-BLACK  
CHRYSLER, FORD  
UNIT PKG.-50

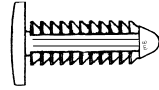

HOLE SIZE-3/16"  
HD. DIAM.-7/16"; STEM-3/4"

**3099**

(GM 22189414)

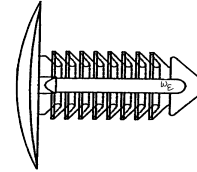

PLASTIC RETAINER-FRONT END  
& ENGINE COMPARTMENT  
GM-BUICK, CADILLAC & CHEVY  
CHRYSLER-JEEP 1999 & UP  
UNIT PKG.-25

HOLE SIZE-9 MM  
HEAD DIAM.-24 MM  
OVERALL LENGTH-23 MM

**3170**

(NISSAN-01553-0075U), (GM-1644290)  
BUMPER COVER RETAINER  
NISSAN-ALTIMA AND  
MAXIMA- 2002 & UP  
GM-VARIOUS MODELS-1986 & UP  
UNIT PKG.-25

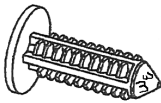

HOLE SIZE-5 MM  
HD. DIAM.-11 MM,  
OVERALL HEIGHT-19 MM

**3261**

(90467-A0008)  
PLASTIC RETAINER  
GRILLE & BUMPER COVER  
TOYOTA/ LEXUS 1995 & UP  
UNIT PKG.- 50



HOLE SIZE-6.35 MM  
HD. DIAM.-19 MM  
OVERALL HT.-17 MM

**3284**

(W711687-S300, 11589181)  
BLACK PLASTIC RETAINER  
BUMPER SUPPORT, HOOD SEAL,  
& FENDER LINER  
FORD FOCUS, CHEVY &  
GMC PICK-UP-2007 & UP  
UNIT PKG.- 25

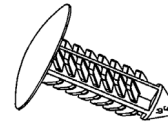

HOLE SIZE-6.3 MM  
HEAD DIAM.-18 MM  
OVERALL LENGTH-23 MM

**3293**

(90467-05125)  
PLASTIC FRONT BUMPER  
COVER RETAINER  
TOYOTA-LEXUS GS SERIES  
2006 & UP  
UNIT PKG.- 25



HOLE SIZE-5 MM  
HEAD DIAM.-16 MM  
OVERALL LENGTH-16 MM

**3297**

(90467-A0002, 90467-08186CO)  
PLASTIC INTERIOR  
TRIM PANEL RETAINER  
TOYOTA - LEXUS-2006 & UP  
UNIT PKG.- 25



HOLE SIZE-7 MM  
HEAD DIAM.-16 MM  
OVERALL LENGTH-20 MM

**3311**

(11562024)  
PLASTIC FENDER LINER, BUMPER COVER  
RETAINER  
GM-CADILLAC ESCALADE,  
CHEVY/ GMC TRUCKS 2007 & UP  
UNIT PKG.-15

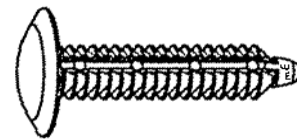

FOR 8 MM HOLE  
18 MM HEAD DIAMETER  
39 MM OVERALL LENGTH

**3364**

(91566-SP0-003)

PLASTIC RETAINER  
TRIM PANELS & SEAT COVERS  
HONDA/ACURA- ACCORD,  
PILOT, RIDGELINE,  
MDX & RDX -1990 & UP  
UNIT PKG.- 15



HOLE SIZE-9 MM  
TOP HD DIAM. -13 MM  
OVERALL LENGTH-22 MM







**3365**

(G032-68-865A-00;  
REPL. 5R3Z-54310D12-BAA)  
PLASTIC RETAINER-COWL, TRIM PANEL,  
FENDER INSULATION & TRUNK CARPET  
MAZDA-5, 6, MIATA, & PROTÉGÉ-  
2009 & UP  
FORD MUSTANG- 2010 & UP  
UNIT PKG.- 25

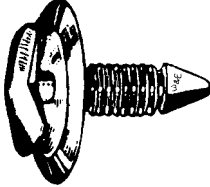
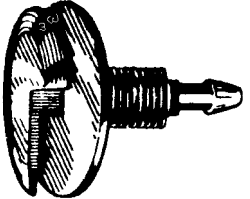

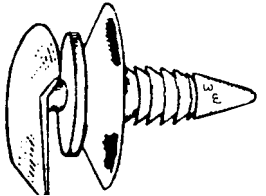
HOLE SIZE-6 MM  
HEAD DIAM. -20 MM  
O/A LENGTH-17 MM

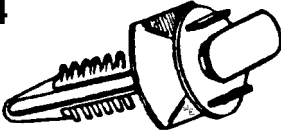
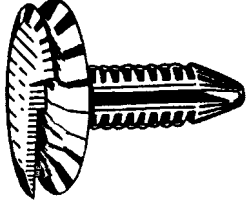
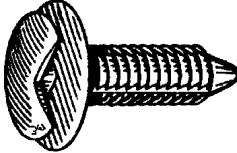
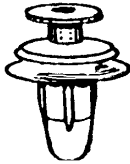
## PLASTIC RETAINERS-DOOR TRIM PANEL CLIPS

<p><b>1205</b></p>  <p>(2064891), (9883583), (332364) (REPLACES 9818648) <b>DOOR TRIM PANEL FASTENER NYLON; GM PRODUCTS-'71 &amp; UP UNIT PKG.-50</b></p>	<p><b>2105</b></p>  <p>(4005470), (N98905101) (9685057), (6003349), (385661-S) <b>RETAINER- INTERIOR DOOR TRIM PANEL- NYLON AMC, GM, FORD, CHRYS., VW UNIT PKG.-50</b></p>	<p><b>2117</b></p>  <p>(12084605), (387496-S) <b>TRIM PANEL FASTENER GM &amp; FORD- '76-'78 &amp; UP UNIT PKG.-25</b></p>
<p><b>2190</b></p>  <p>(OE-6003654) <b>PLASTIC RETAINER FENDER SKIRT TO FRONT &amp; REAR BUMPER, DOOR TRIM CHRYSLER-OMNI &amp; HORIZON '78 &amp; UP UNIT PKG.-50</b></p>	<p><b>2199</b></p>  <p>(171-867-299B) (REPLACES: 823-867-299) <b>PLASTIC DOOR CLIP VOLKSWAGON &amp; AUDI UNIT PKG.-25</b></p>	<p><b>2224</b></p>  <p>(3065575), (16656935) <b>DOOR TRIM TO INNER PANEL FASTENER GM - '77 TO '82 UNIT PKG.-50</b></p>
<p><b>2246</b></p>  <p>(8934-201-681) (34201681) (175-867-299) (REPL.-9818648)</p> <p><b>DOOR TRIM PANEL FASTENER- NYLON AMC, CHRYSLER, VW UNIT PKG.-50</b></p>	<p><b>2274</b></p>  <p>(15600382), (20421800) <b>DOOR PANEL FASTENER PLASTIC, GM- '83 &amp; UP UNIT PKG.-25</b></p>	<p><b>2286</b> (20451401)</p>  <p><b>RETAINER- CONDUIT TO SHEET METAL IN DOORS NYLON- GM "C" BODY UNIT PKG.-25</b></p>
<p><b>2291</b></p>  <p>(363137) <b>TRIM PANEL RETAINER CHEVY &amp; GMC TRUCK-'76 &amp; UP UNIT PKG.-50</b></p> <div style="border: 1px solid black; padding: 2px; width: fit-content; margin-top: 5px;"> <p>HOLE SIZE-1/4"; STEM-1"</p> </div>	<p><b>2375</b></p>  <p>(67771-12010) (67771-22010) (992740825) (8942264920) (95005064)</p> <p><b>DOOR PANEL FASTENER TOYOTA, MAZDA, ISUZU GM-NOVA-'85 UNIT PKG.-25</b></p>	<p><b>3353</b> (91560-SLJ-J01)</p>  <p><b>PLASTIC RETAINER DOOR TRIM PANEL &amp; HEADLINER HONDA-ACCORD, FIT, &amp; MINIVANS-ACURA-MDX, RDX, TL &amp; TSX-'07 &amp; UP UNIT PKG.-15</b></p> <div style="border: 1px solid black; padding: 2px; width: fit-content; margin-top: 5px;"> <p>HOLE SIZE-8.5 MM TOP HEAD DIAM.-13 MM BOTTOM HD DIA. 18 MM OVERALL LENGTH- 17 MM</p> </div>



## PLASTIC RETAINERS-INTERIOR / EXTERIOR

**2416**

(67771-03020)

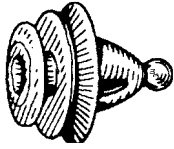

INTERIOR DOOR TRIM  
RETAINER  
TOYOTA-CAMRY '88-UP  
UNIT PKG.-25

HOLE SIZE-8.5 MM  
OVERALL LENGTH- 19 MM

**2417**

(67771-03030)

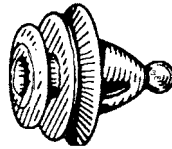

INT. DOOR TRIM RETAINER-  
TOYOTA-CAMRY '88-UP

UNIT PKG.-25

HOLE SIZE-8.5 MM  
OVERALL LENGTH- 21 MM

**2462**

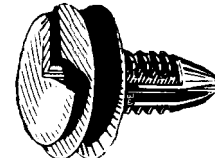

(20374473)

DOOR PANEL FASTENER  
CHEVY-"F" BODY, PONTIAC  
& GM- '82 & UP  
UNIT PKG.-50

**2490**

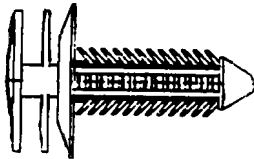

(10153057)

(SUB FOR 15986673)  
DOOR TRIM PANEL CLIP  
GM- "W" BODY '88 & UP  
UNIT PKG.-25

HOLE SIZE-7 MM

**2511**

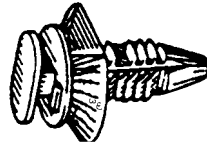

(15612948), (15607165)  
TRIM PANEL RETAINER  
GM TRUCKS- '88 & UP  
(SMALLER THAN W&E #2274)

UNIT PKG.-25

**2552**

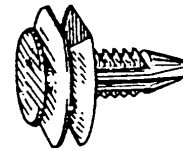

(20734005)

DOOR PANEL FASTENER  
YELLOW COLOR  
GM- '88 & UP

UNIT PKG.-50

HOLE SIZE-1/4"

**2621**

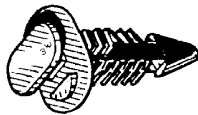

(15953247)

DOOR PANEL FASTENER  
GM TRUCKS- '92 & UP  
UNIT PKG.-25

**2705**

(10126901)

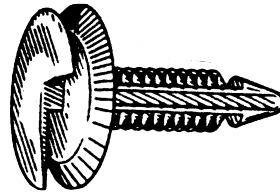

DOOR PANEL FASTENER  
GM- '87 & UP  
UNIT PKG.-50

HOLE SIZE-7 MM  
OVERALL LENGTH-38 MM

**2707**

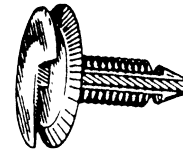

(AMC-4005099), (GM-796255)  
(JEEP-6033862),

(NAVISTAR -0501094C1)  
DOOR PANEL FASTENER  
AMC- '76 & UP; GM- '81 & UP  
JEEP- '91 & UP  
UNIT PKG.-25

**2721**

(OE-15963179)  
(15638413)

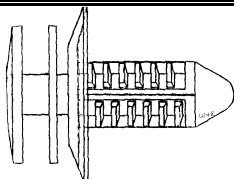

DOOR PANEL FASTENER  
GM TRUCKS- '91 & UP  
UNIT PKG.-50

HOLE SIZE-7 MM

**2726**

(6502991)

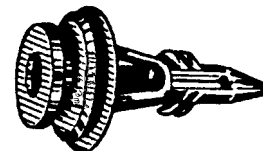

TRIM PANEL RETAINER  
INTERIOR TRIM  
& TAIL GATE  
JEEP-'93 & UP

UNIT PKG.-25

HOLE SIZE-7 MM  
STEM LENGTH-25 MM

## PLASTIC RETAINERS-INTERIOR / EXTERIOR

**2727**

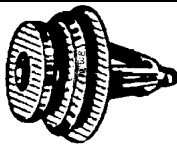

(6502907)  
(SUB FOR 6504014)  
(SUB FOR 6504452-MINIVANS)  
TRIM PANEL RETAINER  
JEEP & DODGE TRUCKS  
'93 & UP  
UNIT PKG.-50

HOLE SIZE-7 MM  
STEM LENGTH-15 MM

**2794**

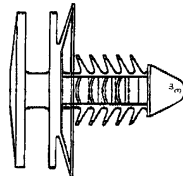

(10287971), (10408480)  
TRIM PANEL RETAINER  
GM-'97 & UP

UNIT PKG.-50

HOLE SIZE-7 MM; HD. DIAM.-18 MM  
STEM-14 MM

**2795**

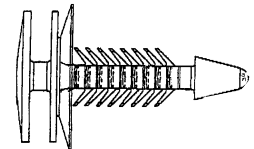

(10285935)  
TRIM PANEL RETAINER  
GM-'97 & UP

UNIT PKG.-50

HOLE SIZE-7 MM; HD. DIAM.-18 MM  
STEM-24 MM

**2849**

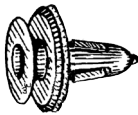

(6503204)  
DOOR TRIM PANEL  
RETAINER  
CHRYSLER- MINIVAN,  
CIRRUS & STRATUS, '95 & UP  
UNIT PKG.-50

HOLE SIZE-7 MM  
STEM-15 MM

**2851**



(GM-95008221, 30006620)  
(TOYOTA-6771-12050)  
(REPLACES-TOYOTA-90467-10161A,  
90467-10161, 67771-12040)  
DOOR PANEL RETAINER-FRONT&REAR  
GEO PRISM, TOYOTA-CELICA,  
COROLLA, PREVIA & LEXUS  
UNIT PKG.-25

HOLE SIZE-9 MM

**2864**

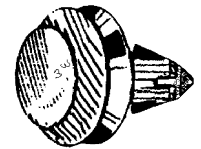

(6505918AA, 6505292AA)  
DOOR TRIM PANEL  
RETAINER  
CHRYSLER VANS- '98 & UP  
UNIT PKG.-25

HOLE SIZE-9 MM  
OVERALL LENGTH-21 MM

**2893**



(67771-06070)  
DOOR TRIM PANEL RETAINER  
TOYOTA- AVALON & CAMRY  
'93 & UP  
UNIT PKG.-15

**2899**

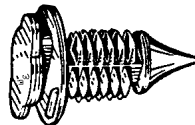

(GM-20298365)  
(CHRYSLER-6013122)  
TRIM PANEL RETAINER  
UNIT PKG.-50

HOLE SIZE-5/16"

**2939**

(6505539-AA)

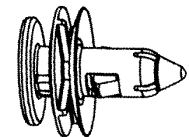

RETAINER-DOOR TRIM PANEL  
JEEP GRAND CHEROKEE-'99 & UP  
UNIT PKG.-25

HOLE SIZE-7 MM; OVERALL LENGTH-22MM

**2948**

(91560-SPO-003)  
DOOR PANEL CLIP-FRONT & REAR  
HONDA-ACCORD, CIVIC,  
PRELUDE, ODYSSEY & DEL SOL  
ACURA-INTEGRA & LEGEND- 1991 & UP  
UNIT PKG.-25



HOLE SIZE-9 MM; TOP HD. DIAM.-13 MM; STEM-12 MM

**2962**

(TOYOTA-62581-14020)  
(MAZDA-9927-40-822)  
TRIM PANEL RETAINER  
TOYOTA, MAZDA  
UNIT PKG.-25



HOLE SIZE-8 MM; SM HD.-14 MM  
LG HD. DIAM.-18 MM ; STEM-14 MM

## PLASTIC RETAINERS-INTERIOR / EXTERIOR

**2978**

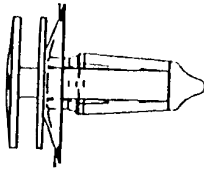

(10257286)  
**DOOR TRIM PANEL  
 RETAINER**  
 GM- MINIVANS-'97 & UP  
 UNIT PKG.-25

HOLE SIZE-7 MM  
 TOP HD.DIAM.-18 MM  
 OVERALL LENGTH-28 MM

**3004**

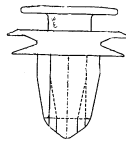

(91560-S84A-A01)  
**INTERIOR TRIM  
 PANEL RETAINER**  
 HONDA ACCORD  
 '98 & UP  
 UNIT PKG.-25

HOLE SIZE-8 MM  
 TOP HEAD DIAM.13 MM  
 OVERALL LENGTH- 15 MM

**3270**



(82315-38000), (94530585)  
**PLASTIC DOOR & TRIM  
 PANEL RETAINER**  
 GM- 2004 & UP  
 HYUNDAI- 1999 & UP  
 KIA- 2001 & UP  
 UNIT PKG.- 25

TOP HEAD DIAM.-13 MM  
 OVERALL HEIGHT-17 MM

**3017**



(75867AA010)  
 (REPLACES 75868AA020)  
**PLASTIC ROCKER PANEL  
 MOULDING CLIP**  
 TOYOTA CAMRY-2002  
 UNIT PKG.-15

HOLE SIZE-8.5 MM  
 TOP HEAD DIAM.13 MM  
 OVERALL LENGTH- 19 MM

**3037**

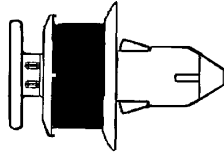

**PLASTIC PUSH RIVET  
 DOOR TRIM PANEL CLIP  
 WITH SEALER**  
 DODGE NEON 2000 & UP  
 UNIT PKG.-15

HOLE SIZE-9 MM  
 TOP HEAD DIAM.- 16 MM  
 FLANGE O.D.-22 MM  
 OVERALL LENGTH-30 MM

**3041**

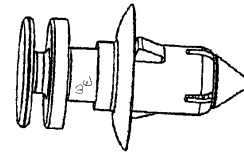

**DOOR TRIM PANEL CLIP**  
 FORD 2001 & UP  
 UNIT PKG.-25

HOLE SIZE-9 MM  
 TOP HEAD DIAM.- 15 MM  
 BOTTOM HD DIAM.-20 MM  
 OVERALL LENGTH-33 MM

**3046**

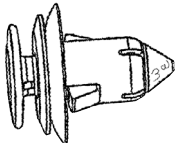

(06505918AA)  
**DOOR TRIM PANEL CLIP  
 YELLOW HEAD**  
 CHRYS. MINIVANS-'01 & UP  
 UNIT PKG.-25

HOLE SIZE-9 MM  
 TOP HEAD DIAM.- 15 MM  
 BOTTOM HD DIAM.-20 MM  
 OVERALL LENGTH-21 MM

**3047**

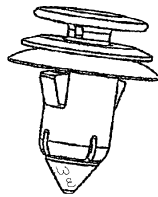

**DOOR TRIM PANEL CLIP  
 GREEN HEAD**  
 CHRYS. VANS-'01 & UP  
 UNIT PKG.-25

HOLE SIZE-9 MM  
 TOP HEAD DIAM.- 15 MM  
 BOTTOM HD DIAM.-20 MM  
 OVERALL LENGTH-26 MM

**3048**



**DOOR TRIM PANEL CLIP  
 GREY HEAD**  
 CHRYS. VANS-'01 & UP  
 UNIT PKG.-25

HOLE SIZE-9 MM  
 TOP HEAD DIAM.- 15 MM  
 BOTTOM HD DIAM.-20 MM  
 OVERALL LENGTH-26 MM

**PLASTIC RETAINERS-INTERIOR / EXTERIOR, PUSH TYPE**

**3059**

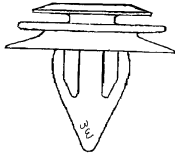

(01553-02821)  
**DOOR PANEL RETAINER  
 NISSAN MAXIMA**

**UNIT PKG.-15**

HOLE SIZE-8 MM  
 OVERALL LENGTH-17 MM

**3095**

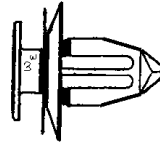

(90467-10188)  
**DOOR TRIM PANEL RETAINER  
 TOYOTA SIENNA-2004**

**UNIT PKG.-25**

HOLE SIZE-8.5 MM  
 OVERALL HEIGHT- 20 MM

**3114**

(15076791)

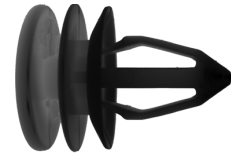

**PLASTIC DOOR TRIM PANEL  
 RETAINER  
 GM- S & T TRUCKS-2002 & UP**

**UNIT PKG.-15**

HOLE SIZE-9 MM  
 TOP HEAD DIAM.-20 MM  
 OVERALL LENGTH-26 MM

**3228**

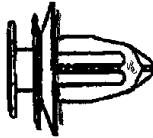

(90467-A0005)  
**PLASTIC INTERIOR TRIM  
 PANEL RETAINER  
 WITH SEALER  
 TOYOTA/LEXUS  
 2001 & UP  
 UNIT PKG.-15**

HOLE SIZE-8.5 MM  
 OVERALL HEIGHT-20 MM  
 TOP HD. DIAMETER-13 MM

**3230**

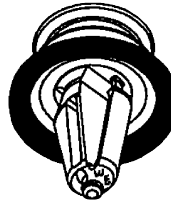

(W713297-S300)  
**PLASTIC DOOR PANEL  
 RETAINER WITH SEALER  
 FORD-FUSION, FOCUS  
 MERCURY MILAN- 2007 & UP  
 UNIT PKG.-25**

HOLE SIZE-9 MM  
 TOP HEAD-16 MM  
 OVERALL HEIGHT-28 MM

**3296**

(11519031)



**PLASTIC DOOR PANEL  
 RETAINER WITH SEALER  
 GM-'03 & UP  
 BUICK, CADILLAC, GMC, CHEVY,  
 OLDS, HUMMER, PONTIAC,  
 SATURN, & SAAB  
 UNIT PKG.-15**

HOLE SIZE-9 MM  
 TOP HEAD-19.5 MM  
 OVERALL HEIGHT-26 MM

**3299**



(11519032)  
**PLASTIC DOOR PANEL  
 RETAINER WITH SEALER  
 (BUICK, CADILLAC, GMC, CHEVY,  
 OLDS, HUMMER, PONTIAC)  
 GM-2002 & UP  
 UNIT PKG.-10**

HOLE SIZE-9 MM  
 TOP HEAD-19.5 MM  
 OVERALL HEIGHT-28 MM

**3315**

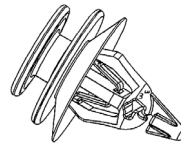

(11561654)  
**PLASTIC INTERIOR  
 TRIM RETAINER  
 GM-BUICK, CADILLAC  
 & CHEVY  
 2006 & UP  
 UNIT PKG.-15**

HOLE SIZE-8.5 MM  
 TOP HD. DIAM.-13MM  
 OVERALL LENGTH-22 MM

**3318**

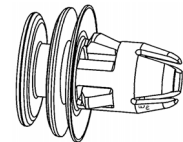

(68061648-AA)  
**PLASTIC TAILLAMP  
 RETAINER  
 CHRYS/DODGE-RAM TRUCKS  
 2009 & UP**

**UNIT PKG.-15**

HOLE SIZE-9.5 MM  
 TOP HEAD DIAM.-15 MM  
 OVERALL LENGTH-20 MM

## PLASTIC RETAINERS- PUSH TYPE

**3344**



(13252118, REPL. 11610605)  
**PLASTIC DOOR PANEL RETAINER**  
 GM-CHEVY, BUICK, GMC, SAAB  
 & CADILLAC- 2010-UP  
**UNIT PKG.-25**

HOLE SIZE-7 MM  
 TOP HEAD DIAM.-13 MM  
 LOWER HD DIAM.-17 MM  
 O/A HEIGHT 21 MM

**3345**

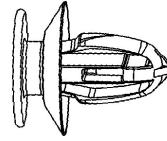

(11610606, REPL. 13252119)  
**PLASTIC DOOR PANEL RETAINER**  
 GM, BUICK, GMC & SAAB  
 2010-UP  
**UNIT PKG.-25**

HOLE SIZE-7 MM  
 TOP HEAD DIAM.-15 MM  
 LOWER HD DIAM.-17 MM  
 O/A HEIGHT 21 MM

**2216**

(AMC/JEEP- 6503454)  
 (FORD-E3D8-4A163CA)  
 (AMC-8934-201-621)  
 (CHRY.-34201621)  
 (GM-14019205,14019206)  
 (CHRY.-06504090)

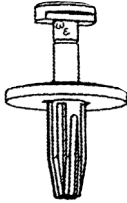

**PLASTIC RIVET-MUD SKIRT**  
 ATTACHING, OTHER USES  
 GM, FORD & CHRYSLER  
 '81 & UP  
**UNIT PKG.-50**

HOLE SIZE-6.3 MM (1/4")  
 FLANGE DIAM.-17.5 MM

**2223**

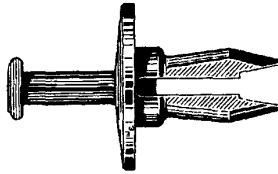

(5973400)  
**PLASTIC RIVET**  
 FRONT & REAR BUMPER  
 ATTACHING STRIP  
 GM- '81 & UP  
**UNIT PKG.-25**

FLANGE DIAM.-1"; SHOULDER -1/8"

**2388**

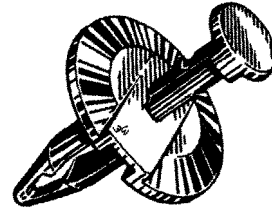

(14093088), (N802781S),  
 (W704340-S300), (55176248)  
**DRIVE RIVET-BUMPER FASCIA**  
 GENERAL USE  
 GM, FORD & CHRYSLER  
**UNIT PKG.-25**

HOLE SIZE-7 MM  
 HD. DIAM.-25 MM

**2398**

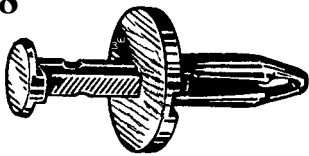

(REPLACES-10134407)  
 (20510029), (20590899), (N803362),  
 (008934202672)  
 (REPLACES-CHRY.-6501925)

**PLASTIC DRIVE RIVET**  
 GM, FORD, AMC & CHRYSLER  
**UNIT PKG.-25**

HOLE SIZE-8 MM  
 HD. DIAM.-17 MM

**2399**

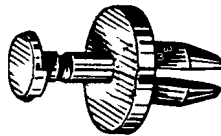

(14071289), (04388293)  
 (175720B010)

**PLASTIC DRIVE RIVET**  
 GM, FORD & CHRYSLER  
**UNIT PKG.-25**

HOLE SIZE-8 MM  
 HD. DIAM.-17 MM

**2413**



(6500787), (16500308),  
 (W705581-S300)  
**NYLON DRIVE RIVET**  
 INTERIOR TRIM & TAIL LAMP  
 RETAINER

HOLE SIZE-5 MM (3/16")  
 BASE HD. DIAM.-7.2 MM  
 PIN HD. DIAM.- 9.5 MM

GM, CHRYSLER & FORD  
**UNIT PKG.-15**

## PLASTIC RETAINERS- PUSH TYPE

**2104**

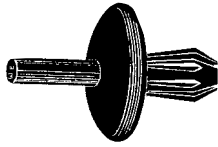

(383142-S)  
**PLASTIC RIVET-GRILLE TO  
 HEADLAMP BRACKET  
 FORD & UNIVERSAL**

**UNIT PKG.-50**

HOLE SIZE-1/4"  
 HEAD DIAM.-5/8"

**2420**

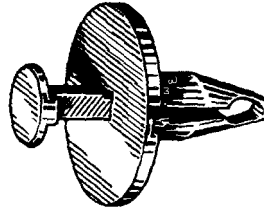

(N804614-S), (N803934-S)  
 (20570245), (W701054-5300)  
**PUSH TYPE RIVET  
 FORD-TAURUS & SABLE; GM  
 UNIT PKG.-25**

HOLE SIZE-8 MM  
 FLANGE DIAM.-25 MM

**2437**

(22535007)

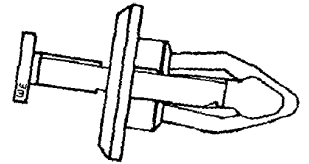

**PUSH TYPE RIVET  
 BUMPER FASCIA  
 GM- '87 & UP  
 UNIT PKG.-25**

HOLE SIZE-9.5 MM  
 SHOULDER DIAM.-12.7 MM  
 FLANGE DIAM.-25 MM  
 PANEL RANGE-7-10 MM

**2438**

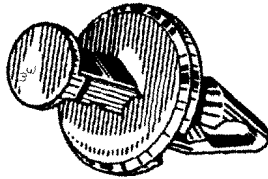

(14103461)  
**PUSH TYPE BUMPER  
 FASCIA RIVET  
 GM-'87 & UP  
 UNIT PKG.-25**

FOR 9.5MM HOLE; FLNG DIA. 22MM  
 SHOULDER DIAM.-12.7 MM  
 PANEL RANGE-4-10 MM

**2453**

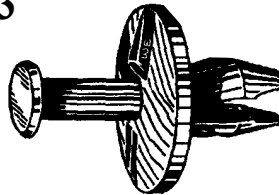

(14045480), (55074801)  
**PLASTIC FASCIA RETAINER  
 (NO SHOULDER)  
 GM & CHRYSLER  
 UNIT PKG.-25**

HOLE SIZE-8MM; HD. DIAM.-25 MM  
 PANEL RANGE-UP TO 6.3 MM

**2458**

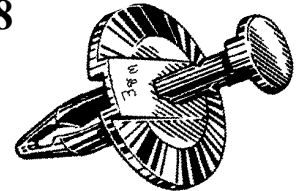

(N803421S), (0650590)  
**SPLASH SHIELD/ FASCIA  
 RETAINER  
 FORD & CHRYSLER  
 UNIT PKG.-25**

HOLE SIZE-6 MM; SHOULDER -8 MM

**2478**

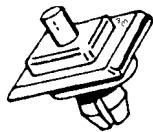

(90678-SAO-003)  
 (90853-671-003)  
**PLASTIC DRIVE RIVET-  
 HONDA**

**UNIT PKG.-15**

HOLE SIZE-8 MM  
 HD.DIAM.-12 X 18 MM  
 SHOULDER-2 MM

**2550**

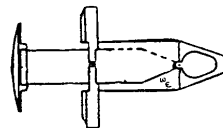

(CHRYSLER-6503598)  
 (GM-21030249,15969147)  
 (FORD-807389S)  
**NYLON PUSH RIVET  
 GM (SATURN), C, K TRUCK,  
 FORD & CHRYSLER**

**UNIT PKG.-25**

HOLE SIZE-8MM  
 HD.DIAM.-20MM  
 PANEL RANGE-3-8 MM

**2551**

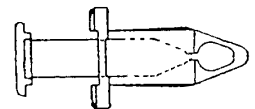

(21075686)  
**NYLON PUSH RIVET  
 GM (SATURN), TRUCK**

**UNIT PKG.-25**

HOLE SIZE-8MM  
 HD.DIAM.-15MM  
 PANEL RANGE-3-8 MM

**PLASTIC RETAINERS- PUSH TYPE**

**2599**

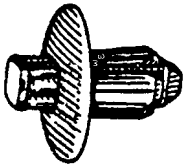

(01553-06721)  
**PUSH RIVET  
 BUMPER COVER  
 NISSAN MAXIMA  
 INFINITY  
 UNIT PKG.-15**

HOLE SIZE-8 MM; HD. DIAM.-20 MM

**2612**

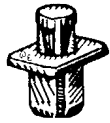

(68814-01G00)  
**PUSH RIVET-COWL  
 GRILLE RETAINER  
 NISSAN TRUCKS  
 '86 & UP  
 UNIT PKG.-25**

HOLE SIZE-5 MM  
 (SQUARE HOLE)

**2614**

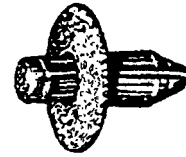

(NISSAN-809905N07),  
 (01553-00755)  
 (TOYOTA-90467-07043)  
**BUMPER PUSH RIVET  
 UNIT PKG.-15**

HOLE SIZE-7 MM  
 HD. DIAM.-18 MM

**2615**



(HONDA- 91545-SEO-0030-W1)  
 (NISSAN-63848-01G00)

**PUSH RIVET-HONDA, NISSAN  
 UNIT PKG.-15**

HOLE SIZE-8 MM  
 HD.DIAM.-20MM

**2617**



(66824-01G00)

**PUSH RIVET NISSAN  
 UNIT PKG.-15**

HOLE SIZE-6 MM  
 HD. DIAM.-12 MM

**2701**

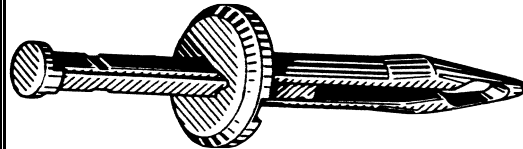

(15959832)  
**PLASTIC DRIVE RIVET  
 LICENSE PLATE BRACKET  
 RETAINER  
 GM TRUCKS**

**UNIT PKG.-5**

HOLE SIZE-10 MM; HD. DIAM.-25 MM  
 SHOULDER-12.7 MM; STEM-41 MM

**2699**

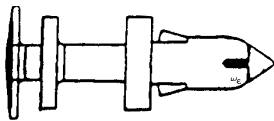

(15960325)  
**DOOR PANEL RETAINER  
 PUSH RIVET  
 GM TRUCKS- '95 & UP  
 UNIT PKG.- 25**

HOLE SIZE-7 MM  
 TOP HD.DIAM.-16 MM  
 OVERALL LENGTH-35 MM

**2717**

(4630253)

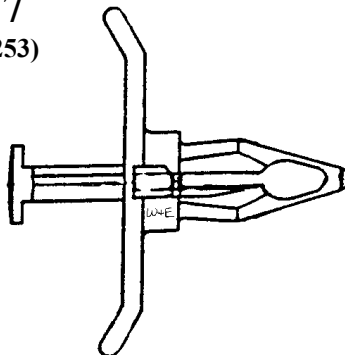

**PLASTIC DRIVE RIVET-REAR  
 FASCIA TO QUARTER PANEL  
 CHRYSLER-1993 & UP  
 UNIT PKG.- 15**

**2729**

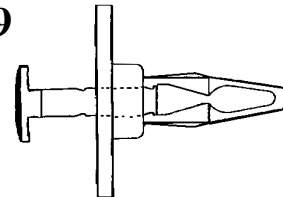

(GM-22587036)  
**PLASTIC DRIVE RIVET  
 FRONT & REAR  
 BUMPER COVERS  
 '95- CHEVY CAVALIER  
 & PONTIAC SUNFIRE  
 UNIT PKG.- 25**

HOLE SIZE-3/8"; HD. DIAM.-1"  
 SHOULDER HT.-5/32"



## PLASTIC RETAINERS- PUSH TYPE

**2739**

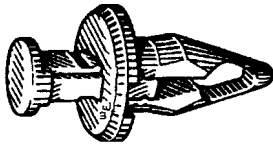

(10157900)  
(REPLACES-15993201)  
**PUSH TYPE PLASTIC RIVET  
BUMPER FASCIA  
FRONT/REAR  
GM-SATURN & OLDS-'90 & UP  
UNIT PKG.-25**

HOLE SIZE-9.5 MM; HD. DIAM.-  
18 MM ;PANEL RANGE-4-7 MM

**2757**

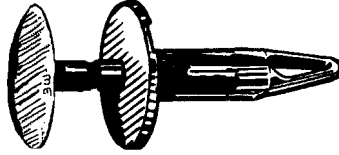

(21095797)  
**PLASTIC DRIVE RIVET  
REAR BUMPER  
GM SATURN-'96 & UP**

**UNIT PKG.-15**

HOLE SIZE-8 MM; HD. DIAM.-20 MM

**2883**

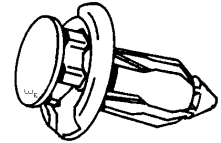

(91503-SZ3-003)  
(REP.-91503-S7A-003)  
**PLASTIC PUSH RIVET  
FRONT GRILLE & BUMPER  
HONDA- '96 & UP**

**UNIT PKG.-10**

HOLE SIZE-10 MM  
FLANGE O.D.-20 MM  
STEM-13 MM

**2885**



(REP.-52161-02020)  
(52161-16010)  
**PLASTIC PUSH RIVET  
REAR BUMPER COVER  
RETAINER  
TOYOTA-TERCEL-'88 & UP  
UNIT PKG.-5**

HOLE SIZE-9 MM;  
HD. DIAM.-18 MM  
STEM LENGTH-28 MM

**2886**



(91501-SO4-003)  
**PLASTIC PUSH RIVET  
FRONT FENDER LINER  
HONDA-CIVIC & DEL SOL  
'93 & UP**

**UNIT PKG.-10**

HOLE SIZE-8 MM; HD. DIAM.-20 MM

**2887**

(15149708)  
(6506008AA)

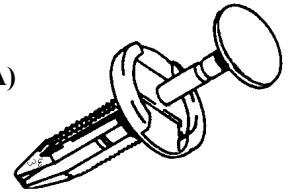

**PUSH RIVET  
RETAINER-RADIATOR,  
FENDER & WHEELHOUSE  
GM C,K TRUCK- '99 & UP**

**UNIT PKG.-25**

HOLE SIZE-6 MM;  
HEAD DIAM.-17 MM

**2889**

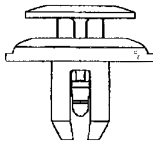

(HONDA 91512-SXO-003)  
(MITSUBISHI MU000319)  
(GM11519949)  
**PLASTIC PUSH RIVET  
FRONT FENDER & BUMPER  
HONDA/ ACURA-'94 & UP  
MITSUBISHI-'02 & UP  
GM/GMC-'07-UP  
UNIT PKG.-25**

HOLE SIZE-8MM  
HEAD DIAM.-20MM  
OVERALL LENGTH- 13.4 MM

**2898**

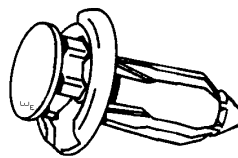

(91503-SZ5-003)  
**PLASTIC PUSH RIVET  
FRONT GRILLE AND BUMPER  
HONDA- '98 & UP**

**UNIT PKG.-10**

HOLE SIZE-10 MM  
FLANGE OD-20 MM  
STEM-17 MM

**2902**

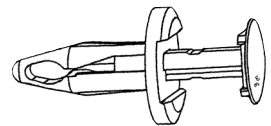

(21077123;W705436-S300)  
**NYLON PUSH RIVET  
WHEEL OPENING, COWL VENT  
& BUMPER COVER  
GM-(SATURN), FORD  
UNIT PKG.-25**

HOLE SIZE-6.3 MM  
FLANGE OD-15 MM  
PANEL RANGE-2-6 MM



**PLASTIC RETAINERS- PUSH TYPE**

**2912**

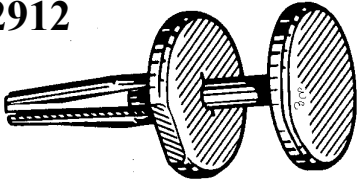

(6503106)  
**PLASTIC PUSH RIVET  
 LOWER MOULDING  
 LIC.Plate BRACKET  
 CHRYSLER JEEP- '93 & UP  
 UNIT PKG.-15**

HOLE SIZE-6.3 MM  
 HD. DIAM.-22 MM

**2931**



(CHRYSLER/DODGE-6504521)  
**PLASTIC DRIVE RIVET  
 FRONT & REAR FASCIA  
 '98-UP  
 UNIT PKG.-25**

HOLE SIZE-8.5 MM  
 HD.DIAM.-16 MM  
 STEM LENGTH-23 MM

**2932**

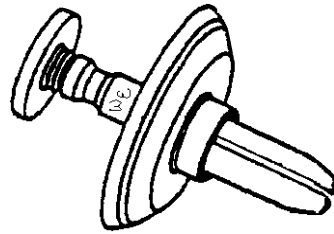

(4805405AA)  
**PLASTIC DRIVE RIVET  
 FRONT BUMPER FASCIA  
 CHRYSLER-CONCORD & INTREPID  
 UNIT PKG.-15**

HOLE SIZE-8.5 MM  
 HD.DIAM.-34 MM;STEM LENGTH- 22 MM

**2953**

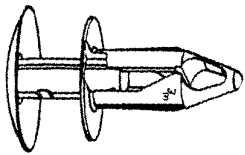

(15153415)  
**PLASTIC PUSH RIVET  
 REAR BUMPER COVER  
 GM C, K TRUCKS-'99 & UP  
 UNIT PKG.-25**

HOLE SIZE-8.5 MM  
 HEAD. DIAM.-20 MM  
 FLANGE O.D.-17 MM

**2958**

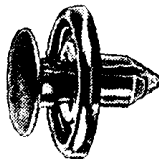

(90467-07166)  
**PUSH TYPE RETAINER  
 FRONT FENDER  
 TOYOTA TERCEL-'94 & UP  
 UNIT PKG.-15**

HOLE SIZE-7 MM  
 HD. DIAM.-20 MM,STEM-8 MM

**2959**



(01553-09321)  
**PUSH TYPE RETAINER  
 FRONT FENDER  
 NISSAN MAXIMA, 300ZX-'94 & UP  
 UNIT PKG.-15**

HOLE SIZE-8 MM  
 HEAD. DIAM.-20 MM  
 STEM-9 MM; PANEL RANGE-4 MM

**2974**

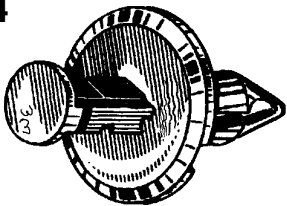

(10077283)  
**PLASTIC DRIVE RIVET  
 BUMPER FASCIA  
 GM- '82 & UP**

UNIT PKG.-25

HEAD DIAM.-1"  
 SHOULDER DIAM.-1/2"

**2985**



(21035345)  
**BLACK PLASTIC PUSH RIVET  
 MOULDING RETAINER  
 GM (SATURN)- '93 & UP**

UNIT PKG.-10

HOLE SIZE-7 MM  
 HD.DIAM.-16 MM  
 STEM LENGTH- 12 MM

**2986**

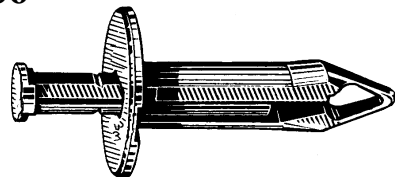

(21077131)  
**PLASTIC DRIVE RIVET  
 BUMPER FASCIA  
 GM-'91 & UP  
 UNIT PKG.-10**

HOLE SIZE-7/16"  
 HD.DIAM.-1-3/16"  
 STEM LENGTH- 2"

## PLASTIC RETAINERS- PUSH TYPE

**2987**

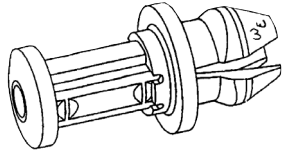

(XL3Z-17E971-AA; XL34-17E971-AA)  
**PLASTIC DRIVE RIVET  
 FRONT BUMPER COVER  
 FORD TRUCKS  
 '99 & UP  
 UNIT PKG.-25**

HOLE SIZE-10 MM; HD.DIAM.-16 MM  
 STEM LENGTH- 12.5 MM

**2991**

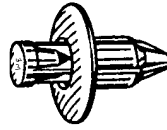

(TOYOTA-90467-07076-CO)  
 REPL.(GEO 96057846)  
**PUSH RIVET-COWL &  
 EXTERIOR TRIM  
 TOYOTA AVALON-2000 & UP  
 SIENNA-1998 & UP  
 GEO METRO/TRACKER-'89 & UP  
 UNIT PKG.-10**

HEAD DIAMETER-15 MM  
 STEM LENGTH-13 MM  
 FOR 6.3 MM HOLE

**3018**

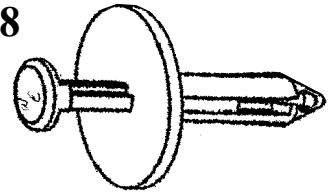

(622A2-9E000)  
**PLASTIC PUSH RIVET  
 BUMPER COVER RETAINER  
 NISSAN ALTIMA-'97 & UP  
 UNIT PKG.-10**

HOLE SIZE-7 MM  
 HEAD DIAM-25 MM  
 OVERALL LENGTH-32 MM

**3019**



(HONDA-90657-SBO-0030)  
 (REPL.91533-SG0-0000)  
**PLASTIC PUSH RIVET  
 BUMPER COVER,  
 SPLASH SHIELD & FENDER SEAL  
 HONDA - ACCORD, ODYSSEY,  
 PRELUDE; ACURA - LEGEND  
 1991 & UP  
 UNIT PKG.-10**

HOLE SIZE-8 MM  
 FLANGE O.D.-11 MM  
 STEM LENGTH-10 MM

**3023**

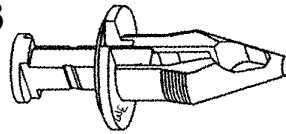

(11519444;11517803)  
**PLASTIC PUSH RIVET  
 BUMPER COVER RETAINER  
 GM-'97 & UP  
 UNIT PKG.-25**

HOLE SIZE-10 MM  
 HEAD. DIAM.-18 MM  
 STEM-26 MM  
 PANEL RANGE-6.2-8.7 MM

**3038**

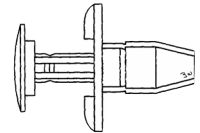

(10301966;10425306)  
**NYLON PUSH RIVET  
 COWL PANEL RETAINER  
 GM "U" VAN, CHEVY,  
 PONTIAC, OLDSMOBILE  
 & BUICK -2001 & UP  
 UNIT PKG.-10**

HOLE SIZE-8 MM  
 HEAD DIAM.-18 MM

**3040**

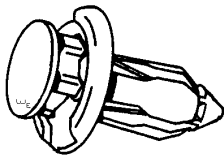

(01553-09241)  
 (Repl. SUBARU-57728-AC-090)  
**PLASTIC PUSH  
 RIVET RETAINER  
 FRONT GRILLE AND BUMPER  
 NISSAN- '94 & UP  
 UNIT PKG.-10**

HOLE SIZE-10 MM  
 HEAD DIAM-18 MM  
 STEM LENGTH-15 MM

**3078**

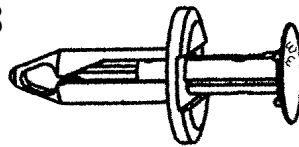

(GM-11518017)  
 (FORD-W 708530-S300)  
**PLASTIC PUSH RIVET  
 BUMPER COVER & FENDER SHIELD  
 GM & FORD-'97 & UP  
 UNIT PKG.-25**

HOLE SIZE-8 MM  
 FLANGE DIAM.-20MM  
 PANEL RANGE-3- 12 MM

**3079**

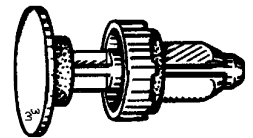

(91508-SM4-003)  
**PLASTIC PUSH RIVET  
 COWL PANEL  
 HONDA ACCORD-'90 & UP  
 ACURA- '96 & UP  
 UNIT PKG.-10**

HOLE SIZE-8 MM  
 HEAD DIAM.-18 MM

## PLASTIC RETAINERS- PUSH TYPE

**3093**

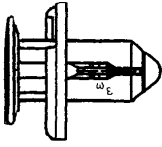

(01553-09611)  
**PLASTIC PUSH RIVET  
 GRILLE & BUMPER FASCIA  
 NISSAN- '94 AND UP  
 UNIT PKG.-15**

HOLE SIZE-8 MM  
 HEAD DIAMETER-18 MM  
 STEM LENGTH-10 MM

**3109**

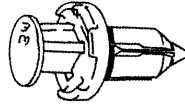

(MR 200300)  
**PLASTIC PUSH RIVET  
 BUMPER COVER &  
 TRIM RETAINER  
 HONDA, MITSUBISHI,  
 CHRYSLER-'97 & UP**

**UNIT PKG.-15**

HOLE SIZE-9 MM  
 FLANGE DIAMETER-18 MM  
 STEM LENGTH-13 MM

**3132**



(25695687)  
**REUSABLE PLASTIC PUSH RIVET  
 RADIATOR SUPPORT  
 & SIGHT SHIELD  
 CADILLAC 2000 & UP  
 UNIT PKG.-10**

HOLE SIZE-9 MM  
 HD.DIAM.-27 MM  
 PIN LENGTH-26 MM

**3133**

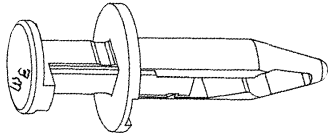

(15994165)  
**PLASTIC PUSH RIVET  
 BUMPER & REAR WHEEL SKIRT  
 GM- SATURN "L" SERIES-2000-UP**

**UNIT PKG.-25**

HOLE SIZE-8 MM  
 HD.DIAM.-16.5 MM  
 STEM LENGTH-27 MM

**3171**

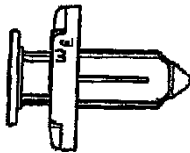

(11296-AG000)  
**PLASTIC PUSH RIVET  
 BUMPER & RADIATOR  
 NISSAN- 2002 & UP  
 UNIT PKG.-25**

HOLE SIZE-8 MM  
 HD. DIAM.-20 MM  
 STEM:-13 MM

**3182**

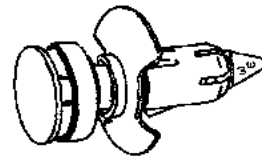

(W704958-S300)  
**PLASTIC PUSH RIVET  
 LOWER DOOR TRIM  
 FORD/LINCOLN TOWN CAR  
 1998 & UP  
 UNIT PKG.-10**

HOLE SIZE-9 MM  
 FLANGE-23 MM  
 OVERALL LENGTH-33 MM

**3187**

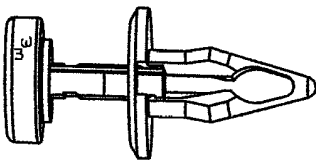

(4857345-AA)  
**PLASTIC PUSH RIVET  
 TAIL LAMP HOUSING RETAINER  
 CHRYSLER-DODGE MINIVANS  
 2002 & UP**

**UNIT PKG.-25**

HOLE SIZE-9.5 MM  
 BASE HD.DIAM.-21 MM  
 STEM LENGTH-23 MM

**3194**

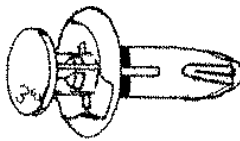

(90505-SX0-003)  
**PLASTIC PUSH TYPE RIVET  
 GARNISH MOULDING  
 RETAINER  
 HONDA-CRV & ODYSSEY  
 2002 & UP**

**UNIT PKG.-20**

HOLE SIZE-8 MM  
 HEAD DIAM.-18 MM  
 STEM LENGTH-15 MM

**3202**

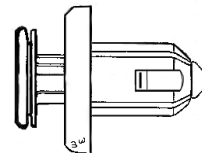

(91505-S9A-0032)  
**PLASTIC BUMPER  
 COVER RETAINER-  
 (WITH METAL INSERT)  
 HONDA-ACCORD, CIVIC,  
 CRV & ELEMENT-  
 ACURA 2006 & UP  
 UNIT PKG.-10**

HOLE SIZE-10 MM  
 FLANGE DIAM.-20 MM  
 PIN LENGTH-25.5 MM



## PLASTIC RETAINERS— PUSH TYPE

**3210**

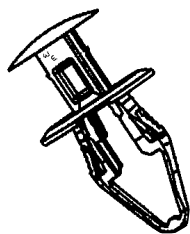

(11561368, 6508712)  
**PLASTIC PUSH RIVET  
 FENDER LINER RETAINER  
 GM, CHRYSLER- 2006 & UP**

**UNIT PKG.-25**

HOLE SIZE-9.5 MM  
 HEAD DIAM.-18 MM  
 BASE STEM LENGTH-20 MM

**3212**

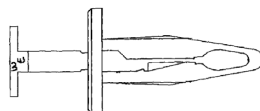

(GM-15681408, 25642453)  
 (FORD-N803709)  
 (CHRYSLER-4857108)  
**PLASTIC FASCIA RETAINER  
 GM, FORD & CHRYSLER  
 1986 & UP**

**UNIT PKG.-25**

HOLE SIZE-6.3 MM  
 HEAD DIAM.-15 MM  
 STEM LENGTH-23 MM

**3214**

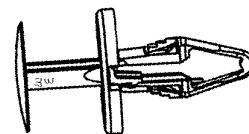

(11589290)  
**PLASTIC PUSH RIVET  
 COWL VENT &  
 BUMPER FASCIA RETAINER  
 GM- 2002 & UP**

**UNIT PKG.-50**

HOLE SIZE-6.5 MM  
 HEAD DIAM.-18 MM  
 STEM LENGTH-20 MM

**3215**

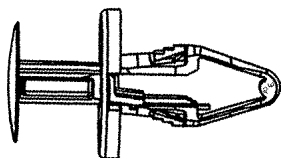

(11589293)  
**PLASTIC PUSH RIVET  
 COWL VENT &  
 FENDER LINER RETAINER  
 GM- 2004 & UP**

**UNIT PKG.-25**

HOLE SIZE-8.5 MM  
 HEAD DIAM.-20 MM  
 STEM LENGTH-22 MM

**3216**

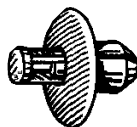

(90467-07117)  
**PLASTIC PUSH RIVET  
 SEAL RETAINER,  
 RADIATOR, BUMPER & COWL  
 TOYOTA-LEXUS  
 1990 & UP**

**UNIT PKG.-10**

HOLE SIZE-7 MM  
 HEAD DIAM.-17 MM  
 STEM LENGTH-8 MM

**3224**

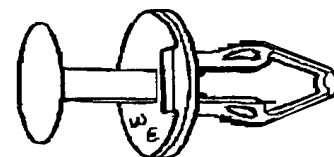

(11589294)  
**PLASTIC PUSH RIVET  
 RADIATOR SITE SHIELD  
 RETAINER, HOOD BRACKET  
 GM-2007 & UP**

**UNIT PKG.-25**

HOLE SIZE-8.5 MM  
 HEAD DIAM.-20 MM  
 STEM LENGTH-24 MM

**3229**

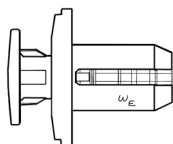

(91503-S0K-A01)  
**PLASTIC PUSH RIVET GRILLE &  
 AIR DEFLECTOR RETAINER  
 HONDA CIVIC, PILOT, &  
 ELEMENT-'03-'08**

**UNIT PKG.-15**

HOLE SIZE-10 MM  
 HD. DIAM.-20 MM; STEM-14 MM

**3232**



(53879-60010)  
**PLASTIC PUSH RIVET  
 FENDER LINER  
 TOYOTA-LAND CRUISER, RAV 4  
 LEXUS-LX 470- 1998 & UP**

**UNIT PKG.-10**

HOLE SIZE-7 MM  
 HEAD DIAMETER-18 MM  
 STEM LENGTH-7 MM

**3235**



(52161-20010)  
**PLASTIC PUSH RIVET  
 BUMPER COVER  
 TOYOTA-2000 & UP  
 (LONGER THAN W&E #2885)**

**UNIT PKG.-10**

HOLE SIZE-9 MM  
 FLANGE DIAMETER-18 MM  
 BASE LENGTH-35 MM

## PLASTIC RETAINERS- PUSH TYPE

**3242**



(OE-91505-ST7-003ZA)  
(OE 90467-08180)  
PLASTIC PUSH RIVET  
HONDA 2000 & UP  
TOYOTA 2004 & UP  
UNIT PKG.- 10

HOLE SIZE-8 MM  
FLANGE DIAM.-17 MM  
PIN LENGTH-26 MM

**3244**

(6506132AA)

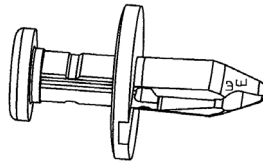

PLASTIC PUSH RIVET-FENDER  
LINER & RADIATOR SHIELD  
RETAINER, CHRYSLER-300,  
SEBRING & STRATUS-2001 & UP  
UNIT PKG.- 25

HOLE SIZE-7 MM  
FLANGE-20 MM  
OVERALL LENGTH-33 MM

**3245**

(11589289)  
(6508863AA)  
(W610713S300)

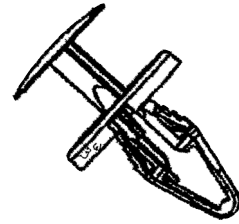

PLASTIC PUSH RIVET-INTERIOR  
TRIM, RADIATOR, SIDE SHIELD,  
& AIR DEFLECTOR RETAINER  
GM, FORD, CHRYSLER-2002 & UP  
UNIT PKG.- 25

HOLE SIZE-6.5 MM  
FLANGE-18 MM  
OVERALL LENGTH-31 MM

**3246**

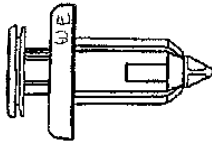

(91506-S9A-003)  
PLASTIC PUSH RIVET  
W/METAL INSERT GRILLE,  
BUMPER COVER, FENDER  
LINER & SPLASH SHIELD  
(LONGER THAN W & E # 3202)  
HONDA/ACURA-2006 & UP  
UNIT PKG.- 10

HOLE SIZE-10 MM  
HEAD DIAM.-20 MM  
PIN LENGTH-30 MM

**3254**



(90467-07211)  
PLASTIC PUSH RIVET  
RADIATOR SEAL, SIGHT  
SHIELD, & GRILLE RETAINER  
TOYOTA/LEXUS-2005 & UP  
UNIT PKG.-10

HOLE SIZE-7 MM  
FLANGE-19 MM  
OVERALL PIN LENGTH-18 MM

**3260**

(5116530AA)  
(GM-15296830)  
(W714415-S300)

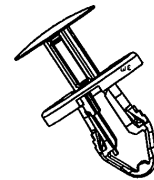

PLASTIC PUSH RIVET  
BUMPER COVER & DOOR  
GM, FORD, CHRYSLER-'07 & UP  
UNIT PKG.- 25

HOLE SIZE-8 MM  
HEAD DIAM.-19 MM  
STEM LENGTH-16 MM

**3263**

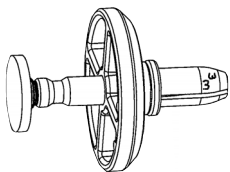

(4806334AA)  
PLASTIC PUSH RIVET  
W/SEALER, BUMPER  
COVER RETAINER  
CHRYSLER, JEEP  
'07 & UP  
UNIT PKG.- 10

HOLE SIZE-8.5 MM  
HEAD DIAMETER-34 MM  
STEM -17 MM, SHOULDER-11 MM

**3273**

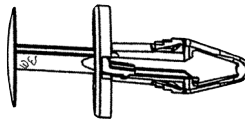

(11589291)  
(W713331-S300)  
PLASTIC PUSH RIVET  
ROCKER MOULDING,  
RADIATOR SIGHT SHIELD,  
BUMPER COVER  
GM, FORD 2006 & UP  
UNIT PKG.- 25

HOLE SIZE-6.5 MM  
HEAD DIAM.-18 MM  
STEM LENGTH- 22 MM

**3275**



(91561-SJD-003)  
PLASTIC PUSH RIVET  
INTERIOR TRIM, PILLAR, FLOOR,  
ROCKER PANEL RETAINER  
HONDA CIVIC & PILOT  
ACURA-MDX-2004 & UP  
UNIT PKG.- 10

HOLE SIZE-8.5 MM  
TOP HEAD DIAM.-15 MM  
OVERALL PIN LENGTH- 38 MM

## PLASTIC RETAINERS- PUSH TYPE

**3285**

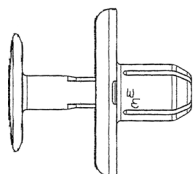

(90467-07214)  
**BLACK PLASTIC PUSH RIVET  
 RADIATOR SPLASH SHIELD  
 RETAINER  
 TOYOTA CAMRY-2007 & UP  
 UNIT PKG.- 20**

HOLE SIZE-7 MM  
 HEAD DIAM.-20 MM  
 OVERALL BASE HEIGHT- 12 MM

**3295**



(90467-07201)  
**PLASTIC PUSH RIVET  
 ENGINE UNDER COVER  
 TOYOTA/LEXUS  
 2002 & UP  
 UNIT PKG.-10**

HOLE SIZE-7 MM  
 HEAD DIAM.-20 MM  
 STEM LENGTH- 10 MM

**3304**



(90467-07164)  
**PLASTIC PUSH RIVET  
 FENDER LINER, &  
 SPLASH SHIELD  
 TOYOTA/LEXUS- 2002 & UP  
 UNIT PKG.-10**

HOLE SIZE-7 MM  
 HEAD DIAM.-20 MM  
 STEM LENGTH- 10 MM

**3306**

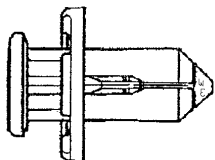

(90914-0007)  
**PLASTIC PUSH RIVET RETAINER  
 FENDER LINER, BUMPER  
 COVER & GRILLE  
 SUBARU-2005 & UP  
 UNIT PKG.-10**

HOLE SIZE-10 MM  
 HEAD DIAM.-21 MM  
 OVERALL LENGTH- 29 MM

**3307**

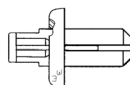

(90914-0059)  
**PLASTIC PUSH RIVET  
 RETAINER, BUMPER COVER  
 SUBARU FORESTER &  
 IMPREZA- 2008 & UP  
 UNIT PKG.-10**

HOLE SIZE-5 MM  
 HEAD DIAM.-10 MM  
 OVERALL BASE HT.- 11 MM

**3326**

(GM 11589295)  
 (FORD  
 W712665-S300)



**PLASTIC PUSH RIVET-FUEL  
 TANK SHIELD, BUMPER COVER,  
 FENDER SHIELD, & INT. PANELS  
 GM & GMC PICK-UP'S  
 CHEVY-COBALT & HHR  
 C/K TRUCKS-PONTIAC G5 & G6  
 UNIT PKG.- 25**

HOLE SIZE-10.5 MM  
 25 MM HEAD DIAMETER  
 3-6 MM PANEL THICKNESS

**3327**

(11589296)

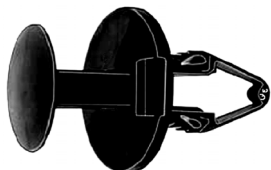

**BLACK PLASTIC PUSH RIVET  
 BUMPER COVER & GENERAL  
 PANEL ATTACHMENT  
 GM-BUICK ENCLAVE  
 GMC-ACADIA- 2008 & UP  
 UNIT PKG.-25**

HOLE SIZE-10.5 MM  
 HEAD DIAM.-25 MM  
 6-9 MM PANEL THICKNESS

**3367**



(11609417)  
**PLASTIC PUSH RIVET  
 FENDER LINER RETAINER  
 GM-CADILLAC & SUV'S  
 2003-UP  
 UNIT PKG.-25**

HOLE SIZE-8.5 MM  
 HEAD DIAM.-19 MM  
 STEM LENGTH- 14 MM

**3369**

(W710250-S300)



**PLASTIC SCREW RIVET  
 BUMPER COVER & ROCKER  
 MOULDING RETAINER  
 FORD EDGE & EXPLORER  
 LINCOLN MKS, MKT & MKX  
 2008-UP  
 UNIT PKG.-20**

HOLE SIZE-8 MM  
 HEAD DIAM.-18 MM  
 STEM LENGTH- 18 MM

## PLASTIC RETAINERS- PUSH/ SCREW TYPE

**3308**



(90467-10183), (88970767)  
**PLASTIC PUSH RIVET  
 FENDER LINER  
 TOYOTA/LEXUS- 2007 & UP  
 GM-PONTIAC VIBE  
 UNIT PKG.-10**

HOLE SIZE-7 MM  
 HEAD DIAM.-18 MM  
 STEM LENGTH- 7 MM

**3346**

(01553-05323)



**PLASTIC PUSH RIVET  
 ROCKER MOULDING, FENDER LINER,  
 RADIATOR SPLASH SHIELD,  
 & INTERIOR TRIM PANEL  
 INFINITY & NISSAN  
 2003 & UP  
 UNIT PKG.-10**

HOLE SIZE-8 MM  
 HEAD DIAM.-20 MM  
 STEM LENGTH- 12 MM

**3362**



(90467-07188)  
**PLASTIC PUSH RIVET  
 FENDER LINER AND  
 MUD FLAP RETAINER  
 TOYOTA-CAMRY,  
 4-RUNNER & TACOMA  
 2002-UP  
 UNIT PKG.-15**

HOLE SIZE-7 MM  
 HEAD DIAM.-15 MM  
 STEM LENGTH- 17 MM

**2361**

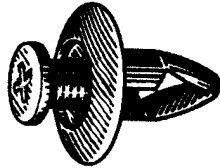

(63844-01A00)  
**EXPANSION SCREW RIVET  
 INNER FENDER SHIELD  
 NISSAN & UNIVERSAL  
 UNIT PKG.-15**

HOLE SIZE-8 MM; HD.DIAM.-20

**2366**



(90467-06017-20), (9926-50-625)  
 (repl.90607-SA5-003)  
**EXPANSION SCREW RIVET  
 PANEL RETAINER  
 TOYOTA,MAZDA,HONDA  
 UNIT PKG.-15**

HOLE SIZE-7 MM  
 FLANGE-15 MM; STEM- 12

**3371**

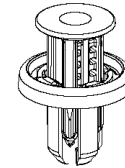

(91505-TM8-0030)  
**PLASTIC PUSH RIVET-GRILLE  
 & BUMPER COVER RETAINER  
 HONDA-ACCORD, INSIGHT  
 & CROSSTOUR-2012-UP  
 UNIT PKG.-15**

HOLE SIZE-10 MM  
 FLANGE DIAM.-20 MM  
 STEM LENGTH-14 MM

**2415**

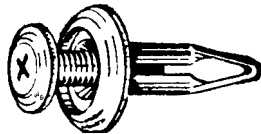

(6502871), (N803946S)  
 (W706350-S300), (20664091)  
**PLASTIC SCREW RIVET  
 EXT. COMPONENT RETAINER  
 FORD, GM & CHRYSLER  
 UNIT PKG.-25**

HOLE SIZE-6.3 MM  
 HD.DIAM.-16 MM

**2237**

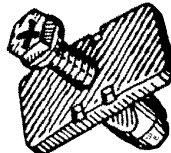

(GM-14013241;12337831)  
 (CHRYSLER-4216535)  
 (VW-175-853-695)  
**GRILLE ATTACHING SCREW  
 AND NUT-PLASTIC  
 UNIT PKG.-25**

HOLE SIZE-9 MM (3/8")  
 HEAD-14 X 26 MM

**3372**

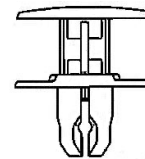

(91501-TR0-003)  
**PLASTIC PUSH RIVET  
 FENDER LINER & GRILLE CLIP  
 HONDA/ACURA-RDX, CIVIC  
 & ACCORD-2012-UP  
 UNIT PKG.-25**

HOLE SIZE-8 MM  
 HD.DIAM.-20 MM  
 STEM LENGTH-10 MM

**2405**



(N803494S)  
**PLASTIC SCREW RIVET  
 FASCIA/GRILLE  
 FORD - '85 & UP  
 UNIT PKG.-25**

HOLE SIZE-6 MM

**2460**





(GM-20664092)  
 (FORD- 804570S)  
 (W705848-S300)  
 (CHRYSLER- 06502790)  
**TRIM RETAINER**

GM, FORD,  
 CHRYSLER  
 UNIT PKG.-25

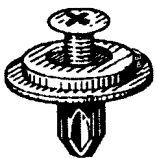
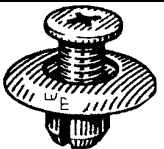
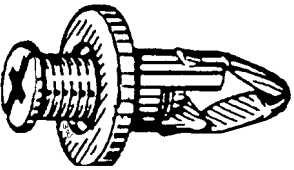
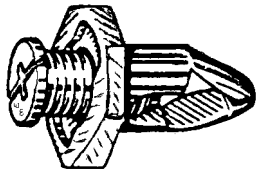
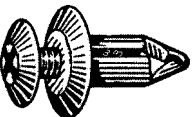
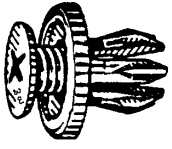
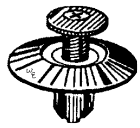
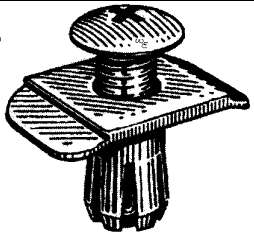

HOLE SIZE-6.3MM  
 HD.DIAM.-18 MM

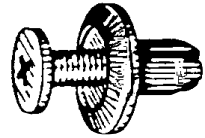
## PLASTIC RETAINERS— SCREW TYPE

<p><b>2475</b></p>  <p>(90688-SB0-003)  <b>PLASTIC SCREW RIVET            &amp; COWL VENT            HONDA            UNIT PKG.-15</b></p> <div style="border: 1px solid black; padding: 2px; margin-top: 5px;">             HOLE SIZE-6 MM; FLANGE-18 MM              PANEL RANGE-2-6 MM           </div>	<p><b>2477</b></p>  <p>(01553-03101)  <b>BUMPER FASCIA RETAINER            NISSAN- '86 &amp; UP            UNIT PKG.-15</b></p> <div style="border: 1px solid black; padding: 2px; margin-top: 5px;">             HOLE SIZE-8 MM; HD.DIAM.-22 MM              PANEL RANGE-2-10 MM              SHOULDER DIAM.-11 MM           </div>	<p><b>2491</b></p>  <p>(90675-SB3-003), (90675-SB0-003)            (63876-D5596), (FB01-56-964)  <b>NYLON SCREW RIVET            HONDA, NISSAN, MAZDA            UNIT PKG.-10</b></p> <div style="border: 1px solid black; padding: 2px; margin-top: 5px;">             HOLE SIZE-8 MM              HEAD DIAM.-20 MM           </div>
<p><b>2548</b></p>  <p>(91502-SM4-000)  <b>SCREW RIVET-BUMPER FASCIA            HONDA -'90 &amp; UP            UNIT PKG.-10</b></p> <div style="border: 1px solid black; padding: 2px; margin-top: 5px;">             HOLE SIZE-10 MM              HD.DIAM.-20 MM; STEM-27 MM           </div>	<p><b>2549</b></p>  <p>(91504-SM4-000)  <b>SCREW RIVET-BUMPER FASCIA            OCTAGONAL HEAD            HONDA -'90 &amp; UP            UNIT PKG.-10</b></p> <div style="border: 1px solid black; padding: 2px; margin-top: 5px;">             HOLE SIZE-10 MM           </div>	<p><b>2592</b>            (66860-01W01)</p>  <p><b>SCREW RIVET- COWL PANEL            TO REINFORCEMENT PLATE            NISSAN            UNIT PKG.-25</b></p> <div style="border: 1px solid black; padding: 2px; margin-top: 5px;">             HOLE SIZE-6 MM              HD.DIAM.-14 MM           </div>
<p><b>2609</b></p>  <p>(91503-SP0-0030)  <b>SCREW RIVET            BUMPER STRIP RETAINER            ACURA-'91 &amp; UP            UNIT PKG.-10</b></p> <div style="border: 1px solid black; padding: 2px; margin-top: 5px;">             HOLE SIZE-10MM; HD.DIAM.-20 MM              STEM LENGTH- 15 MM           </div>	<p><b>2619</b></p>  <p>(NISSAN-80915-29A66, 23270-3895)            (NISSAN-75775-41300)            (MAZDA-1395-68-676, 9926-50-635)            (ISUZU-8942431900, 8941690750)  <b>PLASTIC SCREW RIVET            NISSAN, MAZDA, ISUZU            UNIT PKG.-15</b></p> <div style="border: 1px solid black; padding: 2px; margin-top: 5px;">             HOLE SIZE-6 MM              HEAD DIAM.-20 MM           </div>	<p><b>2624</b></p>  <p>(01553-01393), (BF-82-50-233)  <b>BUMPER COVER CLIP            NISSAN &amp; MAZDA            UNIT PKG.-5</b></p> <div style="border: 1px solid black; padding: 2px; margin-top: 5px;">             HOLE SIZE-10 MM              HEAD SIZE-20 X 30 MM           </div>
<p><b>2613</b>            (90505-SM4-003)</p>  <p><b>SCREW RIVET            SILL PLATE            MOULDING            HONDA ACCORD            '90 &amp; UP</b></p> <div style="border: 1px solid black; padding: 2px; margin-top: 5px;">             HOLE SIZE-8 MM              HEA DIAM.-18 MM           </div> <p><b>UNIT PKG.-10</b></p>	<p><b>2627</b>            (10998-3880)            (8942981190)            (90684-SA5-0030)</p>  <p><b>PLASTIC SCREW RIVET            NISSAN, HONDA, ISUZU            UNIT PKG.-25</b></p> <div style="border: 1px solid black; padding: 2px; margin-top: 5px;">             HOLE SIZE-6 MM; HEAD DIAM.-15 MM           </div>	<p><b>2655</b></p>  <p>(90467-09145)  <b>BUMPER COVER            RETAINER-PUSH RIVET            TOYOTA CAMRY            UNIT PKG.-10</b></p> <div style="border: 1px solid black; padding: 2px; margin-top: 5px;">             HOLE SIZE-9 MM; HD DIAM.              15 MM; STEM - 12 MM           </div>



## PLASTIC RETAINERS— SCREW TYPE

**2682**

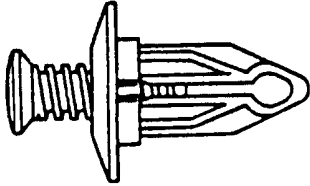

(GM-10140480)  
 (CHRY-06502625)  
 (FORD-309414, W708325S300)  
 SCREW RIVET-BUMPER/GRILLE  
 TRUCKS & VANS-'90 & UP  
 UNIT PKG.-25

HOLE SIZE-12 MM  
 HD.DIAM.-21 MM  
 SHOULDER- 3 MM

**2686**

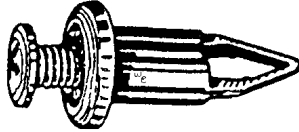

(90467-09093)  
 RETAINER- BUMPER COVER  
 TOYOTA & LEXUS  
 UNIT PKG.-10

HOLE SIZE-9 MM  
 HD.DIAM.-15 MM  
 STEM- 27 MM

**2716**

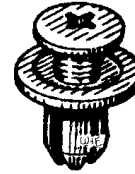

(OE-90657-SA6-0030)  
 (OE-N304-13-356A)  
 PLASTIC SCREW RIVET  
 HONDA, MAZDA  
 UNIT PKG.-25

HOLE SIZE-7 MM; HD.DIAM.-14 MM  
 STEM LENGTH-11 MM

**2718**

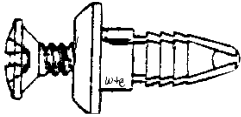

(GM-10195515)  
 (FORD-N805026S)  
 (CHRYSLER-4696488)  
 PLASTIC SCREW RIVET  
 UNIT PKG.-25

HOLE SIZE-17/64"; HD.DIAM.-1/2"  
 PANEL RANGE-17/32"-21/32"  
 LENGTH UNDER HEAD-1-13/64"

**2719**

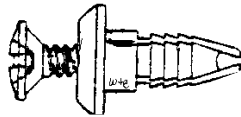

(6502573)  
 PLASTIC SCREW RIVET  
 CHRYSLER-'93 & UP  
 UNIT PKG.-15

HOLE SIZE-1/4" (SQUARE HOLE)  
 HEAD DIAM.-15/32"  
 LENGTH UNDER HEAD-37/64"

**2758**

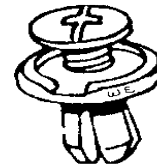

(91512-SM4-003)  
 SCREW RIVET  
 FENDER SPLASH SHIELD  
 HONDA ACCORD '90 & UP  
 UNIT PKG.-15

HOLE SIZE-8 MM  
 HD.DIAM.-20 MM  
 STEM LENGTH- 9 MM

**2882**

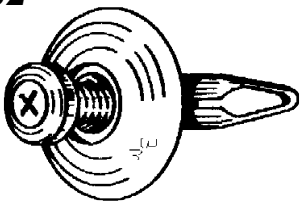

(N804837S)  
 PLASTIC SCREW RIVET  
 INTERIOR PANEL RETAINER  
 FORD-TAURUS/SABLE

UNIT PKG.-25

HOLE SIZE-1/4"; HD. DIAM.-1"

**2884**

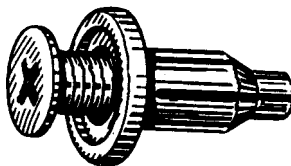

(91502-SPO-003)  
 PLASTIC SCREW RIVET  
 FRONT AND REAR BUMPER  
 HONDA-'90 & UP

UNIT PKG.-5

HOLE SIZE-10 MM  
 HD. DIAM.-20 MM



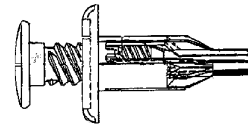

**2897**

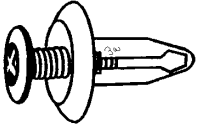
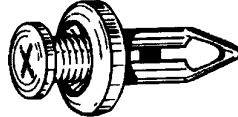
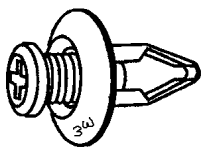
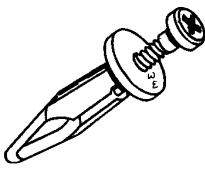
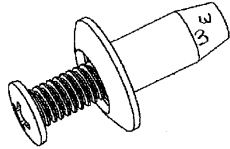
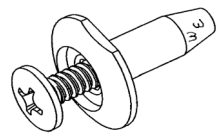

(91561-S84-A00-M1)  
 PLASTIC SCREW RIVET  
 HONDA  
 UNIT PKG.-10

HOLE SIZE-8MM  
 HD.DIAM.-16MM  
 P.R.3-7 MM  
 OVERALL LENGTH-24MM

## PLASTIC RETAINERS- SCREW TYPE

<p><b>2942</b></p>  <p>(96FG16K262AA) SCREW RIVET WHEELHOUSE LINER/ GRILLE FORD FOCUS-2000-2001</p> <p style="text-align: center;">UNIT PKG.-25</p> <div style="border: 1px solid black; padding: 2px; margin-top: 5px;"> <p>HOLE SIZE-6 MM HD. DIAM.-16 MM; STEM-18 MM</p> </div>	<p><b>2977</b></p>  <p>(10053182) (W706264S300) (6503163)</p> <p style="text-align: center;">PLASTIC SCREW RIVET COWL, DOOR TRIM, BUMPER COVER, SPLASH SHIELD GM, FORD &amp; CHRYSLER-'88 &amp; UP</p> <p style="text-align: center;">UNIT PKG.-25</p> <div style="border: 1px solid black; padding: 2px; margin-top: 5px;"> <p>HOLE SIZE-8- 8.5 MM HEAD DIAM.-15 MM</p> </div>	<p><b>3013</b></p>  <p>(W706713-S300) PLASTIC SCREW RIVET BUMPER COVER RETAINER FORD ESCAPE-2001 &amp; UP</p> <p style="text-align: center;">UNIT PKG.-25</p> <div style="border: 1px solid black; padding: 2px; margin-top: 5px;"> <p>HOLE SIZE-8 MM HD. DIAM.-18 MM; STEM-18 MM</p> </div>
<p><b>3024</b></p>  <p>(10246149) PLASTIC SCREW RIVET ROCKER PANEL MOULDING GM- "N" BODIES-'99 &amp; UP</p> <p style="text-align: center;">UNIT PKG.-25</p> <div style="border: 1px solid black; padding: 2px; margin-top: 5px;"> <p>HOLE SIZE-6 MM FLANGE DIAM.-11 MM PANEL RANGE-4.5- 7.5 MM STEM LENGTH-18 MM</p> </div>	<p><b>3112</b></p>  <p>(W706494-S300) PLASTIC SCREW RIVET CLOSED END FENDER WELL LINER RETAINER FORD-TAURUS &amp; SABLE-'99 &amp; UP</p> <p style="text-align: center;">UNIT PKG.-25</p> <div style="border: 1px solid black; padding: 2px; margin-top: 5px;"> <p>HOLE SIZE-8 MM HEAD DIAM.-18 MM; STEM-8 MM</p> </div>	<p><b>3113</b></p>  <p>(N811283-S) PLASTIC SCREW RIVET CLOSED END INTERIOR TRIM &amp; MAT RETAINER FORD-EXPEDITION &amp; NAVIGATOR-'97 &amp; UP</p> <p style="text-align: center;">UNIT PKG.-25</p> <div style="border: 1px solid black; padding: 2px; margin-top: 5px;"> <p>HOLE SIZE-6.3 MM HEAD DIAM.-18 MM STEM-18 MM; SHOULDER- 9.5 MM</p> </div>
<p><b>3226</b></p>  <p>(BC1D-56-145) PLASTIC PUSH RIVET BUMPER COVER FENDER LINER, MUD GUARDS MAZDA-2004 &amp; UP</p> <p style="text-align: center;">UNIT PKG.-15</p> <div style="border: 1px solid black; padding: 2px; margin-top: 5px;"> <p>FOR 8 MM HOLE HEAD DIAMETER-20 MM STEM LENGTH-9 MM,</p> </div>	<p><b>3241</b></p>  <p>(90467-09166) PLASTIC SCREW RIVET (PHILLIPS HEAD) FENDER LINER CLIP TOYOTA-2007 &amp; UP</p> <p style="text-align: center;">UNIT PKG.-15</p> <div style="border: 1px solid black; padding: 2px; margin-top: 5px;"> <p>HOLE SIZE-9 MM SQUARE HOLE FLANGE DIAM.-20 MM PIN LENGTH-20 MM</p> </div>	<p><b>3272</b></p>  <p>(0G032-50037A) PLASTIC SCREW RIVET BUMPER COVER, LOWER AIR DEFLECTOR GRILLE, INTERIOR AND EXTERIOR TRIM KIA- 2000 &amp; UP</p> <p style="text-align: center;">UNIT PKG.-15</p> <div style="border: 1px solid black; padding: 2px; margin-top: 5px;"> <p>FOR 8.5 MM HOLE FLANGE O.D.-18 MM OVERALL BASE LENGTH-15 MM</p> </div>

## RETAINERS—PUSH/ SCREW TYPE, DOOR PANEL, BUMPER

**3274**

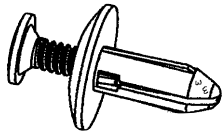

(6508197AA)  
(W706092-S300)  
PLASTIC SCREW RIVET  
GRILLE, FENDER LINER  
REAR QUARTER PANEL  
CHRYSLER, FORD-2007 & UP  
UNIT PKG.- 25

FOR 6.4-6.9 MM HOLE  
HEAD DIAMETER-18 MM  
3-5 MM THICK PANEL

**3287**



(90467-05090-B1)  
BLACK PLASTIC  
SCREW RIVET  
BUMPER COVER RETAINER  
TOYOTA-COROLLA,  
MATRIX, & SCION - 2008 & UP  
UNIT PKG.- 10

FOR 5 MM HOLE  
HEAD DIAMETER-18 MM  
OVERALL BASE LENGTH-10 MM

**3277**



(86590-28000)  
PLASTIC SCREW RIVET  
FENDER LINER, BUMPER  
COVER, GRILLE, & SPLASH  
SHIELD RETAINER  
HYUNDAI- KIA- 2005 & UP  
UNIT PKG.- 15

FOR 8 MM HOLE  
FLANGE O.D.-18 MM  
OVERALL LENGTH-18 MM

**3347**



(90467-05063-C0)  
PLASTIC SCREW RIVET  
HOOD SEAL RETAINER  
TOYOTA CELICA,  
COROLLA & SCION TC  
2000 & UP  
UNIT PKG.-15

FOR 5 MM HOLE  
HEAD DIAM.- 11 MM  
STEM LENGTH- 8 MM

**999**



WIRE ATTACHING CLIP-  
GENERAL USE  
UNIT PKG.-50

**1210**



(OE- 388033-S101)  
DOOR PANEL FASTENER  
REGULAR LONG THROAT  
FORD & UNIVERSAL  
UNIT PKG.-50

**1212**



(OE- 1629341, 4114785)  
DOOR PANEL FASTENER  
CHRYSLER &  
UNIVERSAL  
UNIT PKG.-50

**1213**



DOOR PANEL  
FASTENER REGULAR  
LONG THROAT  
FORD, CHRYSLER &  
RAMBLER  
UNIT PKG.-50

**1220**



HOG RINGS- #5 SIZE  
TO ATTACH SEAT  
CUSHIONS AND SEAT  
BOTTOMS  
ALSO CLIP FOR  
CUSHION SPRING  
UNIT PKG.-500

**3356**

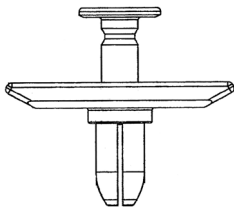

(55157112-AB,-AA)  
PLASTIC PUSH RIVET  
BMPR COVER RETAINER  
JEEP GRAND CHEROKEE  
2005 & UP

UNIT PKG.-15

FOR 9.5 MM HOLE  
HEAD-25X45 MM  
SHOULDER-3 MM

**2200**

(VW-N143893, 3100005)  
(VOLVO-3104426)  
DOOR PANEL FASTENER  
VW & OTHER FOREIGN CARS  
UNIT PKG.-25

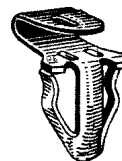







**3359**

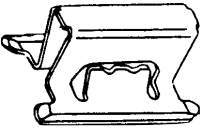

90914-0055  
PLASTIC PUSH RIVET  
W/SEALER-ROCKER  
MOULDING RETAINER  
SUBARU-B9 TRIBECA,  
FORRESTER, LEGACY  
OUTBACK & IMPREZA  
2008 & UP  
UNIT PKG.-5

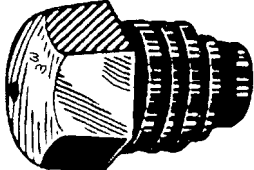
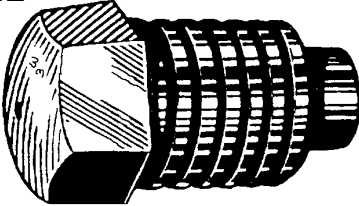
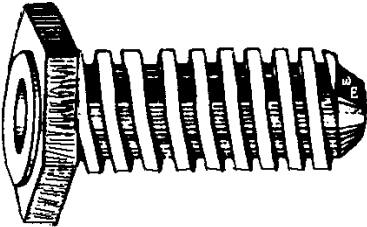
FOR 11 MM HOLE  
FLANGE DIAM.-25 MM  
O/A LENGTH-19 MM

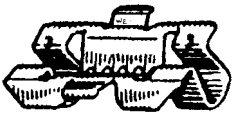
## RETAINERS- DOOR PANEL, BUMPER, HOOD, TRUNK

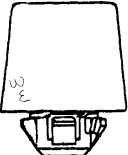
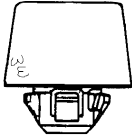
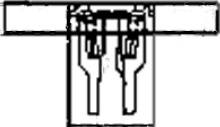
<p><b>2387</b></p>  <p>(OE-90183-03001) BUMPER CUSHION RETAINER TOYOTA- '82 &amp; UP UNIT PKG.-10</p>	<p><b>2440</b></p>  <p>(OE-90468-04030) BUMPER STRIP RETAINER (STAINLESS STEEL) 15 MM WIDE X 27 MM LONG TOYOTA UNIT PKG.-25</p>	<p><b>2441</b></p>  <p>(388378), (1717924) RUBBER TRUNK LID/BUMPER FORD &amp; GM- '79 &amp; UP UNIT PKG.-5</p> <div style="border: 1px solid black; padding: 2px; text-align: center;"> <p>DIAMETER-11/16" OVERALL LENGTH-1-1/4"</p> </div>
<p><b>2442</b></p>  <p>(472450) RUBBER HOOD BUMPER-GM UNIT PKG.-5</p> <div style="border: 1px solid black; padding: 2px; text-align: center;"> <p>DIAMETER-15/16" OVERALL LENGTH- 1-29/32"</p> </div>	<p><b>2443</b> (34201347), (4103165)</p>  <p>NYLON HOOD BUMPER CHRYSLER- '81 &amp; UP UNIT PKG.-5</p> <div style="border: 1px solid black; padding: 2px; text-align: center;"> <p>DIAMETER-18 MM OVERALL LENGTH- 47 MM</p> </div>	<p><b>2560</b></p>  <p>(6501352) DOOR PANEL FASTENER CHRYSLER UNIT PKG.-50</p>
<p><b>2607</b></p>  <p>(62228-61A00) BUMPER CUSHION RETAINER NISSAN UNIT PKG.-10</p>	<p><b>2767</b></p>  <p>(53455-14020) HOOD PROP ROD CLIP TOYOTA UNIT PKG.- 15</p> <div style="border: 1px solid black; padding: 2px; text-align: center;"> <p>HOLE SIZE-14 MM ROD DIAMETER-8 MM</p> </div>	<p><b>2676</b></p>  <p>(FORD-N803749-S32B) (REPLACES GM-22520702, 15594541) (REPLACES- CHRYSLER 6032268) RETAINER-DOOR &amp; QUARTER PANEL TRIM, COWL VENT COVER, INSTRUMENT PANEL &amp; CENTER CONSOLE TRIM UNIT PKG.-25</p>
<p><b>3206</b></p>  <p>(90084-54011) RUBBER HOOD BUMPER TOYOTA-CAMRY &amp; AVALON 2004 &amp; UP UNIT PKG.-10</p> <div style="border: 1px solid black; padding: 2px; text-align: center;"> <p>HOLE SIZE-9 MM OVERALL HEIGHT- 20 MM</p> </div>	<p><b>3209</b></p>  <p>(90084-54012) RUBBER DOOR &amp; TRUNK LID BUMPER TOYOTA 2003 &amp; UP UNIT PKG.-10</p> <div style="border: 1px solid black; padding: 2px; text-align: center;"> <p>HOLE SIZE-9 MM OVERALL HEIGHT- 17 MM</p> </div>	<p><b>3343</b></p>  <p>(11609697, REPL. 11588643) DOOR PANEL &amp; COWL TRIM RETAINER WITH SEALER GM-CADILLAC SRX, CHEVY EQUINOX, GMC TERRAIN 2010 &amp; UP UNIT PKG.-10</p> <div style="border: 1px solid black; padding: 2px; text-align: center;"> <p>FOR 6X20 MM HOLE HEAD 15X30 MM STEM LENGTH-17 MM</p> </div>

## DOOR LOCK ROD END CLIPS/ RETAINERS

<u>PART #</u>	<u>SIDE</u>	<u>DESCRIPTION</u>	
2505	RH	(3454220) CHRYSLER-'71 & UP	
2506	LH	(3454221) CHRYSLER-'71 & UP	
2507	RH	(N805350S) FORD-'69 & UP; (2945108) CHRYSLER-'69 & UP (16601263) GM-'69 & UP; (4003672) AMC-'69 & UP	
2508	LH	(N804344S) FORD-'69 & UP; (2945109) CHRYSLER-'69 & UP (4003673) AMC-'69 & UP	
2509	RH	(20582532)-GM (SUB FOR CHRYSLER-4717165)	
2510	LH	(20582533)-GM (SUB FOR CHRYSLER-4717164)	
2625	RH	(5257478, 4658676)-CHRYSLER (16630688)-GM EACH NUMBER UNIT PKG.-25	

**1290**  
(2811852)



RETAINER FOR  
GLASS GUIDE-PLASTIC  
CHRYSLER & UNIVERSAL  
UNIT PKG.-25

**2538**



(16606936), (166066936)  
DOOR LOCK CLIP  
BUICK, CADILLAC, OLDSMOBILE  
PONTIAC & SATURN  
UNIT PKG.-50

**2273**

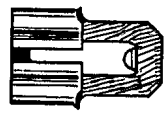

(4234830), (9711304)  
METAL DOOR LOCK CLIP  
GM, GENERAL USE  
UNIT PKG.-25

**2941**



(15685073)  
DOOR LOCK ROD END CLIP  
RIGHT AND LEFT HAND  
FOR 5/32" ROD  
CHEVY S & T AND  
S-10 PICK UP-'95 & UP  
UNIT PKG.-25

**2951**

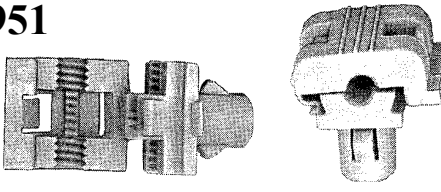

(16675980), (REPLACES-16629990)  
ROD END CLIP  
DOOR & TAIL GATE LOCKS  
GM, FORD, FORD TRUCKS-'90 & UP  
UNIT PKG.-10

**2956**



(91512-SEO-003)  
WINDSHIELD WASHER  
HOSE CLIP  
HONDA ACCORD-'86 & UP  
UNIT PKG.-15

**3012**

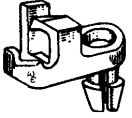

REPLACES-(3081052, 469716)  
DOOR LOCK ROD END CLIP  
GM, CHEV VANS-'77 & UP  
UNIT PKG.-25

**3080**







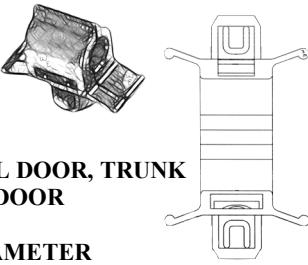



(90652-SB2-023)  
RETAINER- WINDSHIELD  
WASHER HOSE  
FOR 7 MM SQUARE HOLE  
5 MM OD HOSE  
HONDA-'86 & UP  
UNIT PKG.-15

**3328**  
(91558-SE3-003)

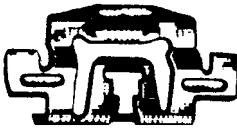

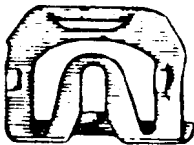
RELEASE CABLE  
RETAINER-BLACK  
PLASTIC; HOOD, FUEL DOOR, TRUNK  
LID, & SLIDING SIDE DOOR  
FOR 7 MM HOLE  
FITS 5 MM CABLE DIAMETER  
HONDA-ACURA, ACCORD,  
CIVIC & CRV- 1991 & UP  
UNIT PKG.-25

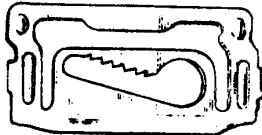
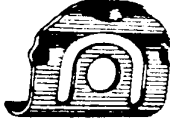
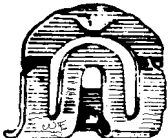
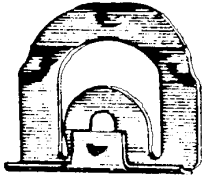
## WINDSHIELD AND REAR WINDOW MOULDING CLIPS

<p><b>3335</b> (69293-30030)</p>  <p><b>DOOR LOCK ROD END CLIP (FOR 8 MM HOLE; 6 MM ROD) TOYOTA-LEXUS-'93 &amp; UP UNIT PKG.-10</b></p>	<p><b>353</b></p>  <p><b>(OE-9731301, 4005540) PLASTIC CLIP-WINDSHIELD, REVEAL MOULDING GM-'74 &amp; UP; AMC '75 &amp; UP UNIT PKG.-50</b></p>	<p><b>354</b></p>  <p><b>(OE-1654048) WINDSHIELD REVEAL MOULDING CLIP GM '75 &amp; UP UNIT PKG.-50</b></p>
<p><b>355</b></p>  <p><b>(OE- 1654047) PLASTIC WINDSHIELD REVEAL MOULDING CLIP- GM COMPACTS (SMALLER SIZE THAN W&amp;E #353) UNIT PKG.-50</b></p>	<p><b>371</b></p>  <p><b>(OE-9808241) REVEAL MOULDING CLIP WINDSHIELD OR BACK WINDOW-CHEVY CAMARO, PONTIAC TEMPEST, BUICK AND CADILLAC- '70-'71 UNIT PKG.-50</b></p>	<p><b>373</b></p>  <p><b>(OE-9854717, 8717859) REVEAL MOULDING CLIP WINDSHIELD (UPPER) &amp; REAR WINDOW GENERAL MOTORS UNIT PKG.-50</b></p>
<p><b>378</b></p>  <p><b>(OE-9662950, 20603072) REVEAL MOULDING CLIP WINDSHIELD (UPPER)-GM UNIT PKG.-100</b></p>	<p><b>379</b></p>  <p><b>(OE-9895598) WINDSHIELD REVEAL MOULDING CLIP-GM UNIT PKG.-50</b></p>	<p><b>384</b></p>  <p><b>(OE-4422660, 4474354) (OE-8736588, 8736589) (OE-8736590) WINDSHIELD AND REAR WINDOW-GM UNIT PKG.-100</b></p>
<p><b>385</b></p>  <p><b>(OE-4506041, 4533669) WINDSHIELD &amp; REAR WINDOW-GM UNIT PKG.-50</b></p>	<p><b>386</b></p>  <p><b>(OE-7634583) REAR WINDOW- GM UNIT PKG.-50</b></p>	<p><b>387</b></p>  <p><b>(OE-D1AB-6542413-AB) (OE-C5ZZ-6542413-B) WINDSHIELD &amp; REAR WINDOW FORD MUSTANG &amp; DATSUN UNIT PKG.-100</b></p>

## WINDSHIELD MOULDING CLIPS/ GLASS GUIDES

**389**



(7693140, 8736586)  
**REVEAL MOULDING CLIP  
 WINDSHIELD AND  
 BACK GLASS  
 GM  
 UNIT PKG.-50**

**390**

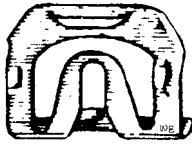

(OE-7698976)  
**UPPER & LOWER REVEAL  
 MOULDING CLIP  
 WINDSHIELD & REAR  
 WINDOW; USED WITH  
 ALUM. MOULDINGS  
 CHEVELLE, F-85  
 TEMPEST, BUICK SPECIAL  
 UNIT PKG.-50**

**672**



**#8 X 3/8"**  
**PHILLIPS HEAD SHEET  
 METAL SCREW  
 (LOW PROFILE HEAD)  
 USED FOR ATTACHING  
 WINDSHIELD &  
 WINDOW REVEAL  
 MOULDING CLIPS  
 UNIT PKG.-100**

**2176**

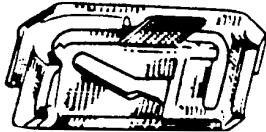

(OE-20169887)  
**PLASTIC WINDSHIELD  
 REVEAL MOULDING CLIP  
 GM- '80 & UP  
 (SIZED BETWEEN W&E #353  
 AND W& E #355 )  
 UNIT PKG.-50**

**2298**



(OE-E3SB-6342413AB)  
**BACK WINDSHIELD  
 REVEAL MOULDING CLIP  
 FORD T-BIRD '83 & UP  
 UNIT PKG.-50**

**2371**

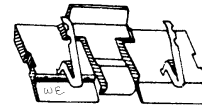

(PICTURE NOT ACTUAL SIZE)  
 (OE-90674-SA6-0030)  
**PLASTIC WINDSHIELD REVEAL  
 MOULDING CLIP- SELF ADHESIVE  
 HONDA-( LIGHT BLUE)  
 UNIT PKG.-10**

**2376**

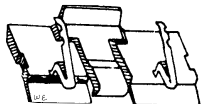

(PICTURE NOT ACTUAL SIZE)  
 (OE-90674692-0030)  
**PLASTIC WINDSHIELD REVEAL  
 MOULDING CLIP- SELF  
 ADHESIVE  
 HONDA-BLACK  
 UNIT PKG.-10**

**2280**

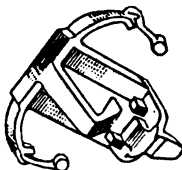

(OE-3066259)  
 (PICTURE NOT EXACT SIZE)  
**GARNISH MOULDING CLIP  
 REAR GLASS- LOWER- GM  
 UNIT PKG.-15**

**2703**

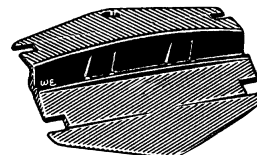

(PICTURE NOT ACTUAL SIZE)  
 (10051034, 10114597,  
 12338011, 20123070,  
 20328600)  
**WINDOW GUIDE  
 FRONT DOOR -GM-'80& UP  
 UNIT PKG.-25**

**2908**

(10142872)  
**GLASS GUIDE  
 FRONT DOOR WINDOW  
 GM-"A" BODIES-'90 & UP  
 UNIT PKG.-10**

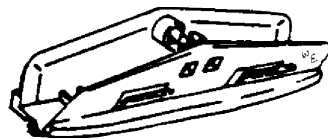

# DOOR GLASS GUIDES, WINDOW REGULATOR, HANDLE PARTS

**2955**

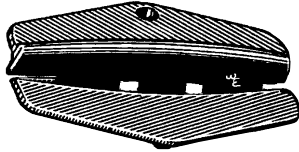

(PICTURE NOT ACTUAL SIZE)  
(20747509, 20478732)  
**GLASS GUIDE  
FRONT DOOR WINDOW  
(REAR GUIDE)  
GM-"C" & "H" BODY  
'85&UP  
UNIT PKG.-25**

**2975**

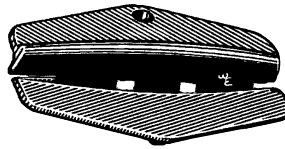

(PICTURE NOT ACTUAL SIZE)  
(20162174, 22543363)  
**WINDOW GUIDE  
FRONT DOOR  
GM-"J" BODIES-'92 & UP  
UNIT PKG.-25**

**2979**

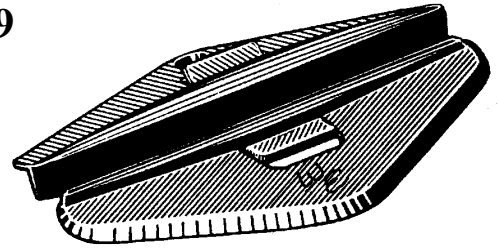

(PICTURE NOT ACTUAL SIZE)  
(12353912, 20487630, 20712172, 20712176)  
**FRONT DOOR WINDOW GUIDE  
(FRONT GUIDE)  
GM-"C" BODIES-'85 & UP  
"U" MINIVANS-'90 & UP  
UNIT PKG.-15**

**3045**

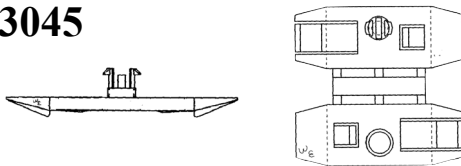

(10274778)  
(PICTURES NOT ACTUAL SIZE)  
**PLASTIC FRONT SIDE DOOR WINDOW  
GUIDE:GM MINVANS, OLDS  
SILHOUETTE, PONTIAC MONTANA,  
TRANSPORT, CHEVY VENTURE &  
LUMINA-1997 & UP  
UNIT PKG.-10**

**3002**

(20369894)  
**RIGHT SIDE**

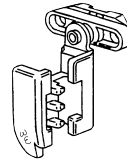

**3003**

(20369895)  
**LEFT SIDE**

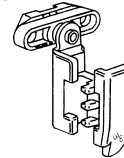

(PICTURES NOT ACTUAL SIZE)  
**WINDOW REGULATOR  
GUIDE  
ASSEMBLY-FRONT DOOR  
"C" & "N" BODY STYLES  
GM-'85 & UP**

**EACH UNIT PKG.-2**

**WINDOW RISER KNOB  
STUD & WASHER**

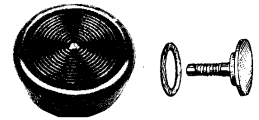

PART #	COLOR	MFG.
2249	CLEAR	GM
2250	BLACK	GM
2251	CLEAR	FORD

**EACH UNIT PKG.-4**

**2579**

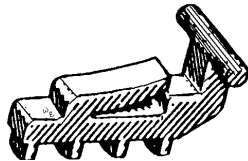

**WINDOW REGULATOR  
TAPE DRIVE BLOCK-GM-'80 & UP  
UNIT PKG.-25**

**2938** *SAVE THE PRICE  
OF A MOTOR, CHANGE PINS!*



(NOT SUPPLIED BY OE)  
**NYLON TORQUE PINS FOR  
WINDOW REGULATOR  
GEARS  
PIN DIAMETER-.492"  
PIN LENGTH-.432"  
FORD & CHRYSLER-'64 & UP**

**UNIT PKG.-15**

**2954**

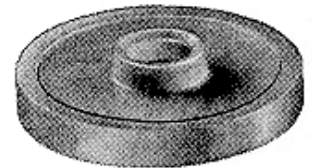

(D9AZ-54234A46-AA)  
**WINDOW GLASS RETAINER  
FRONT/REAR DOORS;  
TAIL GATE BRACKET  
FORD/ LINCOLN-'79 & UP**

**UNIT PKG.-25**

**1262**



**INSIDE DOOR HANDLE  
RETAINING CLIP-GM & FORD**

**UNIT PKG.-100**



## GLASS, WINDOW REGULATOR, SPECIALIZED RIVETS

**2121**

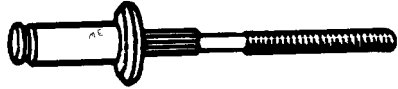

(9436175-GM), (385189-FORD),  
(6031115-CHRYSLER)  
SUPER SPLIT  
ALUM. RIVET/ STEEL MANDREL  
WINDOW REGULATOR RIVET 1/4"  
DIAMETER  
.032-.140" GRIP RANGE  
.257-.261" HOLE REQUIRED  
GM, FORD, CHRYSLER-'76 & UP  
UNIT PKG.-25

**2122**

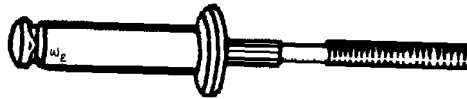

(385323-S100-FORD)  
(6031091-CHRYSLER)  
SUPER-SPLIT "GLASS STOP" RIVET  
ALUM. RIVET/ STEEL MANDREL  
1/4" DIAMETER  
.520-.620" GRIP RANGE  
.257-.261" HOLE REQUIRED  
FORD, CHRYSLER-'76 & UP  
UNIT PKG.-25

**2123**

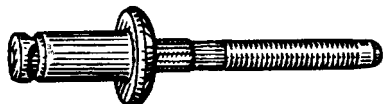

(388047-S100)  
SUPER-SPLIT OUTSIDE DOOR  
HANDLE RIVET- 1/4" DIAM.  
ALUM. RIVET/  
STEEL MANDREL  
.090-.115" GRIP RANGE  
257-.261" HOLE REQUIRED  
FORD, LINCOLN/MERC.-'78 & UP  
UNIT PKG.-25

**2452**

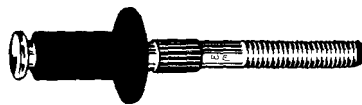

(OE-388047-S102)  
DOOR HANDLE RIVET  
PEEL TYPE-1/4" DIAMETER  
.090-.115" GRIP RANGE  
ZINC & BLACK PHOS.-FORD  
UNIT PKG.-25

**2563**



(9437552)  
3/16" SUPER SPLIT RIVET  
ALUM. RIVET/ STEEL  
MANDREL  
DOOR LATCH ASSEMBLY  
.079-.109" GRIP RANGE-GM  
UNIT PKG.-50

**2622**

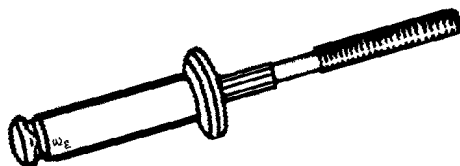

(20184399, 389268-S100)  
WINDOW REGULATOR RIVET  
1/4" DIAMETER; 1/2" FLANGE  
.638-.75" GRIP RANGE  
(ALUM. RIVET/STEELMANDREL)  
GM & FORD  
UNIT PKG.-25

**2728**

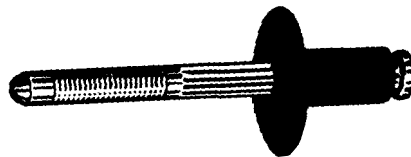

(N804193-S100)  
DOOR HANDLE & LOCK  
RIVET  
1/4" DIAM., 3/4" HEAD, .03-.14"  
GRIP RANGE  
ALUM. RIVET/ STEEL  
MANDREL  
FORD-'84 & UP, BLACK  
UNIT PKG.-25

**2774**



(15715058), (22643056)  
WINDOW REGULATOR  
RIVET  
(1/4" STEEL RIVET/  
MANDREL)  
1/2" FLANGE DIAMETER  
.057"-.157" GRIP RANGE  
GM- '95 & UP  
UNIT PKG.-25

## GLASS, WINDOW REGULATOR, SPECIALIZED RIVETS

**2775**

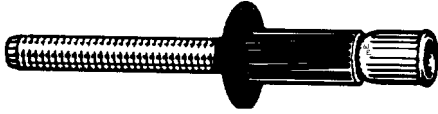

(22578214), (25630258)  
 1/4" DOOR HANDLE &  
 WINDOW REGULATOR RIVET  
 STEEL RIVET/STEEL MANDREL  
 1/2" FLANGE DIAMETER  
 .08-.375" GRIP RANGE  
 GM-'91 & UP  
 BLACK  
 UNIT PKG.-15

**2776**

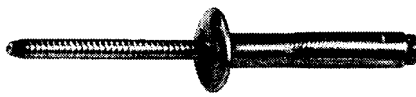

(22579423), (22569178)  
 3/16" DOOR WINDOW/  
 SASH ATTACHMENT RIVET  
 ALUM. RIVET/STEEL MANDREL  
 7/16" FLANGE DIAMETER  
 .312"-.437" GRIP RANGE  
 GM-'92 & UP  
 UNIT PKG.-25

**2890**



(W525170-S417)  
 3/16" SPLIT ALUMINUM  
 RIVET/STEEL MANDREL  
 DOOR HANDLE/WINDOW  
 REGULATOR  
 1/2" FLANGE DIAM.  
 .031-.250" GRIP RANGE  
 FORD-'95 & UP  
 BLACK  
 UNIT PKG.-25

**2891**

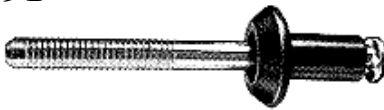

(W525172-S417)  
 1/4" ALUMINUM RIVET  
 STEEL MANDREL  
 (DOOR HANDLE & MISC.)  
 1/2" FLANGE DIAM.; .031-.219" GRIP  
 FORD-'95 & UP  
 BLACK  
 UNIT PKG.-15

**3027**



(22641917, 22585836)  
 3/16" DOOR HANDLE RIVET  
 ALL STEEL  
 3/8" FLANGE O.D.  
 .063-.266" GRIP RANGE  
 GM-'J' & "K" BODIES-'94 & UP  
 BLACK  
 UNIT PKG.-25

**2321**



(GM-9432137)  
 (CHRYSLER-6032138)  
 5/32" ALUMINUM RIVET/  
 STEEL MANDREL  
 COUNTERSUNK HEAD  
 TRUNK LOCK-SEALED END  
 SWIVEL EMBLEM  
 UNIT PKG.-25

**2330**



(372820-S36, S40)  
 1/4" RIVET -1/2" FLANGE  
 FORD STEEL BUMPER RIVET  
 ZINC/YELLOW  
 UNIT PKG.-50

**2353**

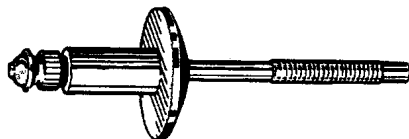

(388442-S100, 6032881)  
 1/4" RIVET- BUMPER ASSEMBLY  
 ALL STEEL- 3/4" FLANGE O.D.  
 .125-.250" GRIP RANGE  
 FORD-'81 & UP, CHRYSLER  
 BLACK  
 UNIT PKG.-20

**2354**

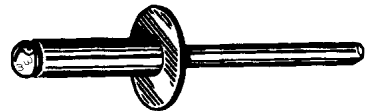

(388664-S100)  
 3/16" RIVET  
 GRILLE RETAINING  
 ALL ALUMINUM  
 3/8-1/2" GRIP RANGE  
 9/16" LARGE FLANGE  
 FORD-'79 & UP  
 BLACK  
 UNIT PKG.-25

## SPECIALIZED BLIND RIVETS

**2480**



(N805592-S100)  
(GM-25618730)  
3/16" RIVET-ALL ALUMINUM  
(SCUFF PLATE TO SILL)  
(7/16" FLANGE)-.078-.236"  
GRIP RANGE-BLACK  
GM, FORD-LINCOLN-'89 & UP  
UNIT PKG.-20

**2630**

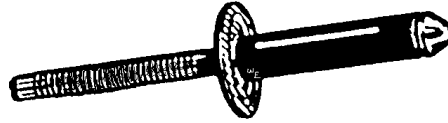

CHRYSLER-(6035201), FORD-(N806830-S100)  
1/4" ALL ALUMINUM RIVET  
BUMPER COVER AND  
LICENSE PLATE BRACKET  
11/16" FLANGE DIAM., .187-.375" GRIP RANGE  
BLACK  
UNIT PKG.-15

**2688**



REPLACES-(N805759-S100)  
1/8" ALL ALUMINUM RIVET  
FOR WINDSHIELD  
SIDE RAIL  
3/8" FLANGE DIAMETER  
.063-.125" GRIP RANGE  
FORD-'89 & UP  
BLACK  
UNIT PKG.-50



PART #

DESCRIPTION

**2749** (N803933-S101) 1/8" CLOSED END  
ALL ALUMINUM RIVET-BLACK  
(15/64" HEAD DIAMETER)  
(3/16-1/4" GRIP RANGE)  
LUGGAGE RACK ATTACHMENT  
FORD & UNIVERSAL  
UNIT PKG.-50

**2750** (390428-S100) 3/16" CLOSED END  
ALL ALUMINUM RIVET-BLACK  
(3/8" HEAD DIAMETER)  
(3/8-1/2" GRIP RANGE)  
LUGGAGE RACK ATTACHMENT  
FORD & UNIVERSAL  
UNIT PKG.-25

**2852**



(N804851-S100)  
1/4" ALL ALUMINUM RIVET  
9/16" FLANGE; UP TO .250" GRIP RANGE  
TAURUS-SABLE '96 & UP  
BLACK  
UNIT PKG.-15

**2858**

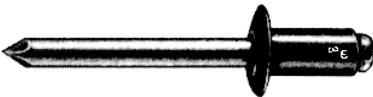

(N808426-S100)  
1/4" ALL ALUMINUM RIVET  
(1/2" FLANGE DIAMETER)  
(1/16-1/4" GRIP RANGE)  
BUMPER FASCIA  
FORD- BLACK  
UNIT PKG.-25

**2888**





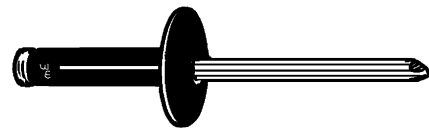

(15022087)  
HEADLIGHT RETAINER  
1/4" ALL STEEL  
SHOULDER RIVET  
(19/32" FLANGE DIAM., 25/64"  
SHOULDER DIAM.)  
(.047-.079" GRIP RANGE)  
GM BLAZER- '98 & UP  
ZINC  
UNIT PKG.- 10

**3332**

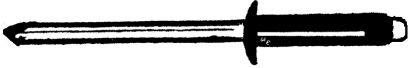
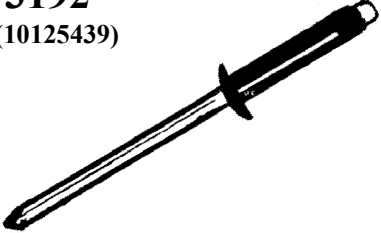
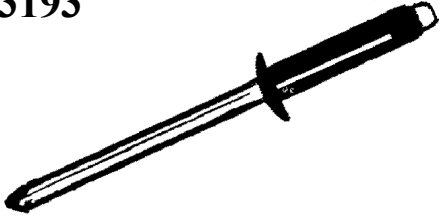
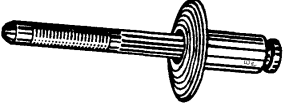
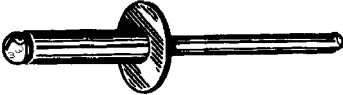

(11516807)  
3/16"-BLACK- ALL ALUMINUM  
SPLIT TYPE- RIVET  
BMPR FASCIA/LICENSE PLATE  
BRACKET-5/8" FLANGE  
.047-.359" GRIP RANGE  
GM '90 & UP-UNIVERSAL  
UNIT PKG.-25

## SPECIALIZED BLIND RIVETS

<p><b>3190</b></p>  <p>(GM-10131511) (REPL. FORD-N807620-S100) (CHRYSLER-6034212) 5/32" ALL ALUMINUM SPECIAL SPLIT RIVET-5/16" FLANGE, .04- .275" GRIP RANGE WHEEL OPENINGS, BUMPERS, ROOF RACKS BLACK UNIT PKG.-25</p>	<p><b>3192</b> (10125439)</p>  <p>3/16" ALL ALUMINUM SPECIAL SPLIT RIVET BODY PANEL &amp; MOULDINGS 3/8" FLANGE .04-.354" GRIP RANGE GM VANS-1990 &amp; UP BLACK UNIT PKG.-25</p>	<p><b>3193</b></p>  <p>(10201332) 3/16" ALL ALUMINUM SPECIAL SPLIT RIVET 3/8" FLANGE;.150-.472"GRIP RANGE DOOR LOCK, MOULDINGS, DASH INSULATION BLACK GM -1990 &amp; UP UNIT PKG.-25</p>
<p><b>3217</b></p>  <p>(N803138-S), (REPL-N804523S, 9442361, 25609048) 3/16" SPLIT RIVET LARGE FLANGE (ALUMINUM RIVET/ STEEL MANDREL) (9/16" FLANGE DIAMETER) (.046-.203" GRIP RANGE) FORD, GM UNIT PKG.-25</p>	<p><b>3219</b></p>  <p>(N900-845-01) 5/32" ALUMINUM RIVET/ STEEL MANDREL LARGE FLANGE (15/32"DIAM.) 1/4"-3/8" GRIP RANGE WHEELHOUSE MOULDING RETAINER-BLACK VW &amp; UNIVERSAL UNIT PKG.-25</p>	<p><b>3220</b></p>  <p>(11610383) 1/4" STEEL RIVET/ STEEL MANDREL 1/2" DOME HEAD, 1/64"-1/8" GRIP RANGE GM &amp; UNIVERSAL ZINC PLATED UNIT PKG.-25</p>
<p><b>3288</b></p>  <p>(9439719) 3/16" LARGE FLANGE RIVET STEEL RIVET/STEEL MANDREL 5/8" FLANGE DIAMETER .250-.375" GRIP RANGE BUMPER FASCIA RETAINER GM BLACK UNIT PKG.-50</p>	<p><b>3289</b></p>  <p>(20325696) 1/8" RIVET ALUMINUM RIVET/ STEEL MANDREL .325" FLANGE DIAMETER .125-.187" GRIP RANGE REAR WINDOW GASKET RETAINER-GM UNIT PKG.-50</p>	<p><b>3298</b></p>  <p>(979878-6) ALL ALUMINUM RIVET SPECIAL SPLIT TYPE BLACK PLASTIC HEAD BUMPER COVER &amp; WHEELHOUSE MOULDING 5 MM RIVET, 12 MM FLANGE VOLVO UNIT PKG.-15</p>

**PLASTIC CAPPED BLIND RIVETS ALUMINUM RIVET/ STEEL MANDREL  
TOYOTA/ LEXUS 1998 AND UP**

**3247**

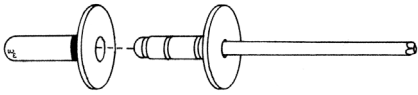

**(90269-04006)  
DOOR DRIP MOULDING RETAINER  
UNIT PKG.- 15**

DIAMETER-3.2 MM (1/8")  
HOLE SIZE-4 MM (5/32")  
FLANGE-8 MM (5/16")  
GRIP RANGE-1.2- 4 MM ( 3/64-5/32")

**3248**

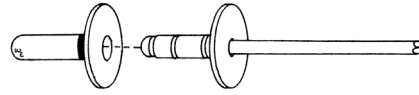

**(90269-04050)  
WINDSHIELD/ TRUNK MOULDING RETAINER  
GS & SC MODELS  
UNIT PKG.- 15**

DIAMETER-3.2 MM (1/8")  
HOLE SIZE-4.3 MM (11/64")  
FLANGE-8 MM (5/16")  
GRIP RANGE-1.4- 3.2 MM ( 1/16-1/8")

**3249**

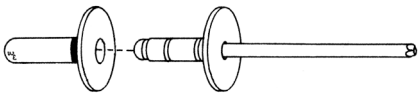

**(90269-04051)  
(REPLACES-90269-A0006)  
DOOR WINDOW MOULDING RETAINER  
CAMRY / ES & IS  
UNIT PKG.- 15**

DIAMETER-3.2 MM (1/8")  
HOLE SIZE-4.4 MM (11/64")  
FLANGE-6 MM (15/64")  
GRIP RANGE-TO 3.4 MM ( 9/64")

**3250**

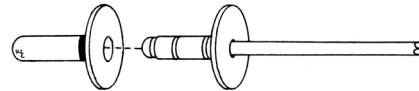

**(90269-04053)  
MOULDING RETAINER  
LAND CRUISER / LX-470  
BLACK RIVET  
UNIT PKG.- 10**

DIAMETER-3.2 MM (1/8")  
HOLE SIZE-4.3 MM (11/64")  
FLANGE-8 MM (5/16")  
GRIP RANGE-1- 3.2 MM ( 1/32-1/8")

**3251**

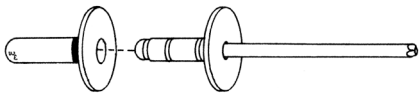

**(90269-05054)  
GAS FILLER DOOR/WINDSHIELD  
SIDE MOULDING CAMRY & SIENNA  
UNIT PKG.- 10**

DIAMETER-4 MM (5/32")  
HOLE SIZE-5.2 MM (13/64")  
FLANGE-14 MM (9/16")  
GRIP RANGE-1.4 MM ( 1/32-11/64")

**3252**

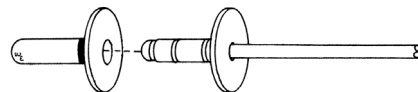

**(90269-05065)  
BUMPERS / GENERAL USE ALL MODELS 2004 & UP  
UNIT PKG.- 10**

DIAMETER-4 MM (5/32")  
HOLE SIZE-5.2 MM (13/64")  
FLANGE-12 MM (15/32")  
GRIP RANGE-4- 6.5 MM ( 5/32-7/64")

**3253**

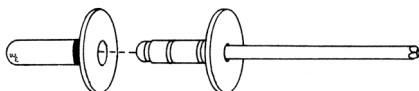

**(90269-06013)  
GAS FILLER DOOR, CAMRY/ IS-300  
UNIT PKG-15**

DIAMETER-4.8 MM (3/16")  
HOLE SIZE-6.2 MM (1/4")  
FLANGE-14 MM (35/64")  
GRIP RANGE-1- 3 MM ( 1/32-1/8")

## STANDARD BLIND RIVETS

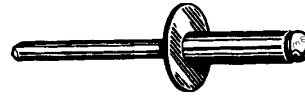

UNIT		RIVET			
PANEL PART #	PKG.	HEAD	MATERIAL	DIAM.	THICKNESS
1250 (ABA 4-3)	250	*Narrow Flange	Aluminum Rivet/Aluminum Mandrel	1/8"	Up to 1/4"
2130 (SBS 4-2)	250	Dome	Steel Rivet/Steel Mandrel	1/8"	Up to 1/8"
2131 (SBS 4-4)	250	Dome	Steel Rivet/Steel Mandrel	1/8"	1/8 to 1/4"
2132 (SBS 4-6)	100	Dome	Steel Rivet/Steel Mandrel	1/8"	1/4 to 3/8"
2133 (SBS 5-6)	100	Dome	Steel Rivet/Steel Mandrel	5/32"	1/4 to 3/8"
2134 (SCS 4-2)	100	Countersunk	Steel Rivet/Steel Mandrel	1/8"	Up to 1/8"
2135 (SCS 4-4)	100	Countersunk	Steel Rivet/Steel Mandrel	1/8"	1/8 to 1/4"
2136 (FBS 4-3)	100	*Narrow Flange	Stainless Steel Rivet/Steel Mandrel	1/8"	Up to 3/16"
2137 (ABA 6-2)	100	Dome	Aluminum Rivet/Aluminum Mandrel	3/16"	Up to 1/8"
2138 (ABA 6-4)	100	Dome	Aluminum Rivet/Aluminum Mandrel	3/16"	1/8 to 1/4"
2139 (ABA 6-6)	100	Dome	Aluminum Rivet/Aluminum Mandrel	3/16"	1/4 to 3/8"
2162 (ABA 66L)	100	Large Flange	Aluminum Rivet/Aluminum Mandrel	3/16"	1/4 to 3/8"
2928 (ABA68L)	50	Large Flange	Aluminum Rivet/Aluminum Mandrel	3/16"	3/8 to 1/2"
2263 (ABA 610L)	50	Large Flange	Aluminum Rivet/Aluminum Mandrel	3/16"	1/2 to 5/8"
2470 (ABA 44L)	250	Large Flange	Aluminum Rivet/Aluminum Mandrel	1/8"	1/8 to 1/4"
2537(OE9432552)	100	Large Flange	Aluminum Rivet/Steel Mandrel	1/8"	1/8 to 3/16"
2471 (ABA 4-6)	250	Dome	Aluminum Rivet/Aluminum Mandrel	1/8"	5/16 to 3/8"
2472 (ABA 4-8)	100	Dome	Aluminum Rivet/Aluminum Mandrel	1/8"	3/8 to 1/2"
2536 (ABA 4-4)	250	Dome	Aluminum Rivet/Aluminum Mandrel	1/8"	3/16 to 1/4"
2792 (SCS43)	100	Countersunk	Stainless Steel Rivet/Steel Mandrel	1/8"	Up to 3/16"
2856 (ABA 64L)	50	Large Flange	Aluminum Rivet/Aluminum Mandrel	3/16"	1/8 to 1/4"
2929 (SBS68L)	50	Large Flange	Steel Rivet/Steel Mandrel (OE-547609)	3/16"	3/8 to 1/2"
2857 (SBS 8-8)	25	Dome	Steel Rivet/Steel Mandrel	1/4"	3/8 to 1/2"

\*Use to Replace Welded Studs on Body- For plastic Clips

### BLACK RIVETS- ALUMINUM RIVET/ ALUMINUM MANDREL



<u>PART #</u>	<u>DESCRIPTION</u>	<u>UPKG</u>
2688 (ABA42L)BA	1/8" DOME HEAD (3/8" FLANGE DIAM.) (1/16 - 1/8" PANEL THICKNESS)	50
2590 (ABA46) BA	1/8" DOME HEAD (5/16 - 3/8" PANEL THICKNESS)	100
2588 (ABA66L) BA	3/16" DOME HEAD (LARGE FLANGE-5/8" DIAM.) (1/4- 3/8" PANEL THICKNESS)	50
2589 (ABA66) BA	3/16" DOME HEAD (1/4 - 3/8" PANEL THICKNESS)	50

### STEEL RIVET BACKUP WASHERS- PLATED

<u>Part #</u>	<u>Size</u>	<u>Upkg.</u>	<u>Part #</u>	<u>Size</u>	<u>Upkg.</u>
985	1/8"	500	2194	3/16"	500
986	1/8"	1000	2521	13/64"	250

(47/64"-O.D.; 3/64" THICK)

## NYLON BLIND RIVETS

(FOR PLASTIC RIVET TOOL SEE NK-5 (PG. 136) (FOR PLASTIC RIVET ASSORTMENTS SEE NKS-50- (PG.152); NRA-60-(PG.152)

**2264**

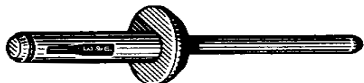

(FORD-8048635), (GM-20432975)  
 (CHRYSLER-6500899,6500859)  
 (VW-175-853-577), (AMC-34202855)  
 NYLON BLIND RIVET  
 HOLE DIAM: 5 MM (3/16")  
 PANEL RANGE- 3 MM- 6 MM  
 (1/8-1/4")  
 HEAD DIAM.- 12 MM (1/2")  
 UNIT PKG.-25

**2266**

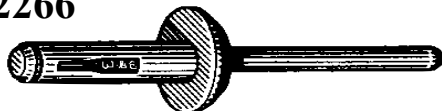

(FORD-N803043S), (KA01500Z1)  
 (GM-15506827, 15506921)  
 (14063981; REPL. GM-15614746)  
 (CHRY.-6500911; REP-34201631)  
 (AMC-8934-201-631)  
 NYLON BLIND RIVET  
 HOLE DIAM: 6.3 MM (1/4")  
 PANEL RANGE- 4 MM- 10 MM (5/32-3/8")  
 HEAD DIAM.- 17 MM (11/16")  
 UNIT PKG.-25

**2267**

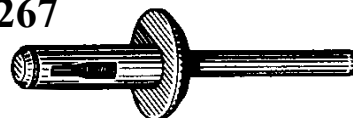

(GM-20433026, 14070914)  
 (CHRYSLER-4370132)  
 (VW-175-553-577A)  
 NYLON BLIND RIVET  
 HOLE DIAM: 6.3 MM (1/4")  
 PANEL RANGE- 2.5 MM- 5 MM  
 (3/32-3/16")  
 HEAD DIAM.- 18 MM (45/64")  
 UNIT PKG.-25

**2265**

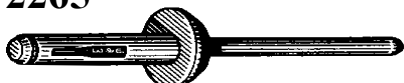

(CHRYSLER-6500898)  
 NYLON BLIND RIVET  
 HOLE DIAM: 5 MM (3/16")  
 PANEL RANGE- 6 MM- 10 MM  
 (1/4-3/8")  
 HEAD DIAM.- 12 MM (1/2")  
 UNIT PKG.-25

**2641**

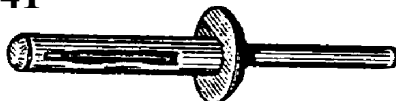

(GM-25524005)  
 NYLON BLIND RIVET  
 HOLE DIAM: 6 MM (1/4")  
 PANEL RANGE- 4 MM- 8.5 MM  
 (5/32-21/64")  
 HEAD DIAM.- 13 MM (1/2")  
 UNIT PKG.-25

**2640**



(GM-20465395, 20612732)  
 (CHRY-6004212,  
 FORD-W712991S300)  
 NYLON BLIND RIVET  
 HOLE DIAM: 5 MM (3/16")  
 PANEL RANGE- 3 MM- 4 MM  
 (1/8-5/32")  
 HEAD DIAM.- 9 MM (23/64")  
 UNIT PKG.-25

**2642**

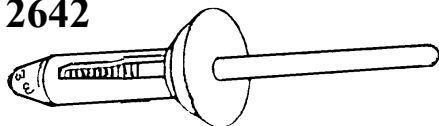

(15732202), (4630088)  
 (REPLACES-4630660)  
 COUNTERSUNK NYLON BLIND RIVET  
 HOLE DIAM: 6.3 MM (1/4")  
 PANEL RANGE-.07 MM-4.5 MM  
 (1/32-11/64")  
 2 MM SHOULDER  
 HEAD DIAM.- 17 MM (11/16")  
 UNIT PKG.-25

**2485**

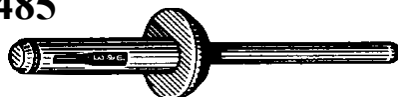

(GM-20452072, 10184895)  
 (FORD-N803862S, W70432-S300)  
 (CHRY-6501559)  
 NYLON BLIND RIVET  
 HOLE DIAM: 6.3 MM (1/4")  
 PANEL RANGE- 4 MM- 10 MM  
 (5/32-3/8")  
 HEAD DIAM.- 13 MM (1/2")  
 UNIT PKG.-25

**2653**

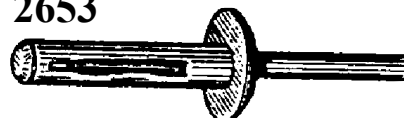

(CHRYSLER-6503860, 4370138)  
 (FORD-N804675S)  
 NYLON BLIND RIVET  
 HOLE DIAM: 6.3 MM (1/4")  
 PANEL RANGE- 8 MM- 12 MM  
 (5/16-1/2")  
 HEAD DIAM.- 16.8 MM (21/32")  
 UNIT PKG.-25

**2270**



(PICTURE SMALLER THAN ACTUAL SIZE)  
 (GM-20421672, 15955172)  
 NYLON BLIND RIVET  
 HOLE DIAM: 6.3MM (1/4")  
 PANEL RANGE- 2.5 MM- 5 MM  
 (3/32-3/16")  
 HEAD DIAM.- 13.08 MM (1/2")  
 UNIT PKG.-25

**2439**

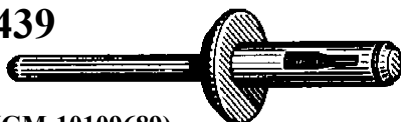





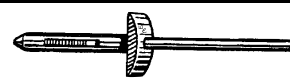

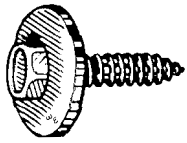
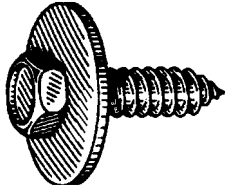
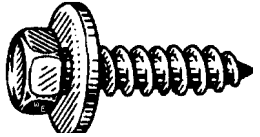
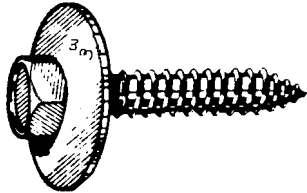

(GM-10109689)  
 NYLON BLIND RIVET  
 HOLE DIAM: 7 MM (9/32")  
 PANEL RANGE- 2.5 MM- 6 MM  
 (3/32-15/64")  
 HEAD DIAM.- 18 MM (45/64")  
 UNIT PKG.-25

**2355**

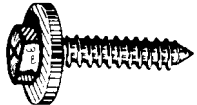

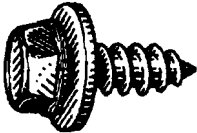
(PICTURE SMALLER THAN ACTUAL SIZE)  
 (N804583-S)  
 NYLON BLIND RIVET  
 HOLE DIAM.-3.96MM(5/32")  
 PANEL RANGE- 6 MM-10.5 MM  
 RECTANGULAR HD-8X15MM  
 COWL VENT GRILLE  
 FORD AEROSTAR-'86 & UP  
 UNIT PKG.-25

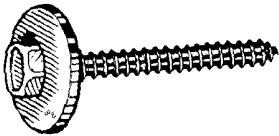
## HEX HEAD SCREWS-LOOSE WASHER

<p><b>2193</b></p>  <p>(11503892), (11503403) (sub for 11514314) 4.2-1.41 X 20 MM UNSLOTTED-INDENTED HEX HD SCREW WITH LOOSE WASHER (16 MM WASHER; 7 MM HEX) PANEL TO FRAME, ALSO GRILLE GM AND UNIVERSAL UNIT PKG.-50</p>	<p><b>2256</b></p>  <p>(11507083) 6.3 MM X 25 MM HEX HD SCREW (24 MM LOOSE WASHER) GM &amp; UNIVERSAL BLACK UNIT PKG.-25</p>	<p>HEX HEAD SHEET METAL SCREW (11/16" LOOSE WASHER; 3/8" HEAD)-AB</p>  <p><b>2328</b>-1/4 X 3/4" <b>2329</b>-1/4 X 1"  ZINC PLATED EACH UNIT PKG.-50</p>
<p><b>2287</b></p>  <p>(REPLACES- 11503436) 6.3 X 35 MM (1/4 X 1-3/8") HEX HEAD SCREW WITH 24 MM (15/16") LOOSE WASHER BLACK GM &amp; UNIVERSAL  UNIT PKG.-25</p>	<p><b>2322</b></p>  <p>(11504056), (11503396) (11503483) 4.2-1.41 X 20 MM (#8 X 3/4") UNSLOTTED HEX HD SCREW (7 MM HEX; WITH 12 MM LOOSE WASHER) GM- "J" &amp; "X" BODIES BLACK UNIT PKG.-100</p>	<p><b>2514</b></p>  <p>(6033801)  #8 X 1" INDENTED HEX HEAD PHILLIPS TAPPING SCREW WITH 7/16" LOOSE WASHER CHRYSLER &amp; UNIVERSAL BLACK PHOSPHATE  UNIT PKG.-50</p>
<p><b>2342</b></p>  <p>#8 X 3/4" HEX HEAD SCREW WITH 1/2" LOOSE WASHER "HI-LOW" THREAD (USE FOR PLASTIC OR FIBERGLASS) UNIT PKG.-50</p>	<p><b>2423</b></p>  <p>(11505022) 6.3 X 20 MM HEX WASHER HEAD SCREW WITH 17 MM LOOSE WASHER (10 MM HEX) GM &amp; UNIVERSAL-BLACK UNIT PKG.-25</p>	<p><b>2489</b></p>  <p>(11503397, 11514377) (REPLACES 11514845) 4.2 X 25 MM HEX HEAD SCREW WITH 12.5 MM LOOSE WASHER (7 MM HEX) GM AND UNIVERSAL-BLACK UNIT PKG.-50</p>
<p><b>3317</b> (11518755)</p>  <p>4.2-1.4 X 35 MM INDENTED HEX HEAD SCREW-AB (7 MM HEX) WITH 17 MM LOOSE WASHER-BLACK UNIT PKG.-50</p>	<p><b>3373</b></p>  <p>6.3-1.81 X 20 MM PHILIPS HEX SCREW WITH 13 MM FREE SPINNING WASHER-(10 MM HEX) BLACK ZINC UNIT PKG.-50</p>	



## HEX HEAD SCREWS-LOOSE WASHER

**2634**

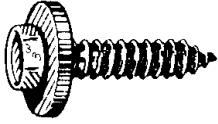

(11505023), (11500996)  
**6.3 X 25 MM HEX HEAD SCREW  
 WITH 17 MM LOOSE WASHER  
 (10 MM HEX)  
 BLACK  
 GM & UNIVERSAL  
 UNIT PKG.-50**

**2684**



(11513895)  
**6.3 X 35 MM HEX HEAD SCREW  
 WITH 12 MM LOOSE WASHER  
 (10 MM HEX)  
 GM & UNIVERSAL  
 BLACK PHOSPHATE  
 UNIT PKG.-25**

**2730**



**#10 X 1"  
 HEX HEAD SCREW-AB  
 WITH 5/8" LOOSE WASHER  
 BLACK  
 UNIT PKG.-50**

**2746**



(11505204)  
**4.2 X 20 MM TORX PAN HEAD  
 SEMS SCREW  
 STAINLESS STEEL  
 (8 MM LOOSE FLAT WASHER)  
 BLACK  
 UNIT PKG.-50**

**2782**

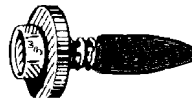

(25640776)  
**4.2-1.41 X 20 MM  
 UNSLOTTED-INDENTED  
 HEX HEAD SCREW  
 LOOSE WASHER  
 (15 MM WASHER; 7 MM HEX)  
 GM-BLACK WITH SEALER  
 UNIT PKG.-50**

**2800**

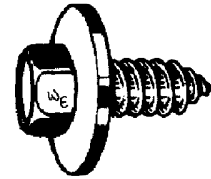

(GM 11501003)  
**8 MM X 20 MM HEX HD  
 SHEET METAL SCREW WITH  
 24 MM LOOSE WASHER  
 (13 MM HEX)  
 BLACK  
 UNIT PKG.-25**

**2853**



**5 MM X 16 MM PHILLIPS  
 TRUSS HEAD SCREW  
 16 MM LOOSE WASHER  
 JAPANESE CARS/ UNIVERSAL  
 BLACK/ ZINC  
 UNIT PKG.-50**

**2920**

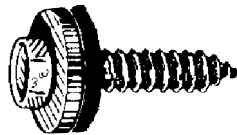

(10016640)  
**6.3 X 25 MM HEX HEAD  
 SEMS-AB  
 WITH SEALER 10 MM HEX  
 16.5 MM WASHER-BLACK  
 UNIT PKG.-50**

**2940**



**4.2 X 30 MM (#8 X 1-3/16")  
 PHILLIPS (POZI) PAN HEAD SHEET METAL  
 SCREW WITH 8 MM LOOSE WASHER  
 MARKER LENS, TAIL LENS  
 GM & UNIVERSAL-FOR EXTERNAL USE  
 BLACK  
 UNIT PKG.-50**

**3316**

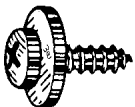







**4.2-1.4 X 13 MM  
 PHILLIPS PAN HEAD-SCREW-AB  
 WITH 12 MM ATTACHED  
 FREE SPINNING WASHER  
 (#8 X 1/2"; 1/2" WASHER)-BLACK  
 UNIT PKG.-100**

**STAY UP TO DATE WITH NEW ITEMS  
 BULLETIN AND SPECIALS**

**EMAIL, CALL OR FAX NEW ITEM SUGGESTIONS**

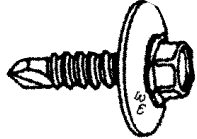
**WWW.WESALES.COM**

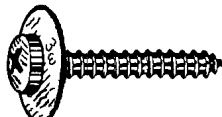
## HEX HEAD SCREWS-LOOSE WASHER-BLACK

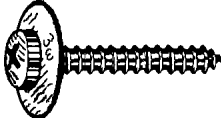
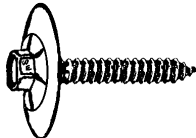
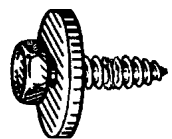
<p><b>2981</b></p>  <p>(GM 11514415) 4.2-1.41 X 35 MM UNSLOTTED INDENTED HEX HEAD SCREW WITH 7 MM HEX; 12 MM LOOSE WSHR BLACK UNIT PKG.-50</p>	<p><b>3015</b></p>  <p>4.2-1.41 X 20 MM INDENTED HEX WASHER HEAD SELF DRILLING SCREW WITH ATTACHED 12 MM LOOSE WASHER 7 MM HEX BLACK UNIT PKG.-50</p>	<p><b>3016</b></p>  <p>4.2-1.41 X 20 MM INDENTED HEX WASHER HEAD SELF DRILLING SCREW WITH ATTACHED 16 MM LOOSE WASHER; 7 MM HEX BLACK UNIT PKG.-50</p>
<p><b>3050</b></p>  <p>(FORD-W707484-S900) 4.2-1.41 X 35 MM (#8 X 1-3/8") PHILLIPS POZIDRIVE SCREW AB WITH 16 MM FREE SPINNING WASHER ZINC/BLACK UNIT PKG.-50</p>	<p><b>3051</b></p>  <p>(GM-15967438) 4.8-1.59 X 35 MM (#10 X 1-3/8") PHILLIPS POZIDRIVE SCREW AB WITH 12 MM FREE SPINNING WASHER ZINC/BLACK UNIT PKG.-50</p>	<p><b>3101</b></p>  <p>(N806088-S58) (4.2-1.41 X 25 MM) (#8 X 1") PHILLIPS PAN HEAD SHEET METAL SCREW-AB WITH ATTACHED FREE SPINNING WASHER (11 MM WASHER O.D) FORD BLACK UNIT PKG.-50</p>
<p><b>3110</b></p>  <p>(N808592-S100) 4.2-1.41 X 25 MM (#8 X 1") PHILLIPS PAN HEAD SCREW-AB WITH 16 MM ATTACHED FREE SPINNING WASHER FORD BLACK UNIT PKG.-50</p>	<p><b>3111</b></p>  <p>(W710441-S) 4.2-1.41 X 25 MM UNSLOTTED-INDENTED HEX WASHER HEAD SCREW WITH LOOSE WASHER (22 MM WASHER; 7 MM HEX) FORD &amp; UNIVERSAL BLACK UNIT PKG.-50</p>	<p><b>3117</b></p>  <p>4.8-1.59 X 16 MM (#10 X 5/8") HEX HEAD SHEET METAL SCREW-AB WITH 19 MM LOOSE WASHER 8 MM HEX FORD &amp; UNIVERSAL ZINC/BLACK UNIT PKG.-50</p>

## SHEET METAL SCREWS-BLACK

**3118**

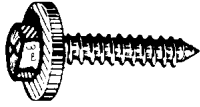

(11588286)  
4.2-1.4 X 20 MM (#8 X 3/4")  
PHILLIPS INDENTED HEX HEAD  
SHEET METAL SCREW-AB  
17 MM LOOSE WASHER; 7 MM HEX  
GM  
BLACK  
UNIT PKG.-50

**3238**

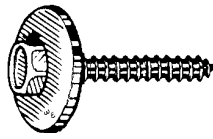

(25655545), (REPL.-11515354)  
4.2-1.4 X 25 MM  
HEX HEAD SCREW-AB  
(17 MM LOOSE WASHER)  
(7 MM HEX)- BLACK  
UNIT PKG.- 50

**3257**

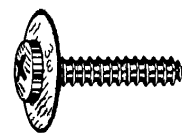

(FORD W710921-S; repl.N801603-S2)  
4.2-1.41 X 20 MM  
(#8 X 3/4"; 5/8" WASHER)  
PHILLIPS-POZI DR- PAN HD  
SCREW-AB;W/ 16 MM WASHER  
BLACK  
UNIT PKG.- 50

### PHILLIPS FLAT HEAD SCREWS-BLACK



<u>PART#</u>	<u>SIZE</u>
2557	#8 X 1/2"
2558	#8 X 3/4"
2584 (# 6 HEAD)	#8 X 3/4"

EACH NUMBER UNIT PKG.-100

**2225**



(OE-11501903)  
PHILLIPS FLAT WASHER HD. SCREW  
POZIDRIVE  
4.2 MM X 10 MM (11 MM, 7/16" WASHER)  
GM & UNIVERSAL  
BLACK  
UNIT PKG.-100

**2859**

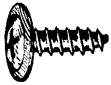

(REPLACES-  
GM-11505104, 11514970)  
4.2 X 13 MM (#8 X 1/2")-AB  
(11 MM WASHER DIAMETER)  
PHILLIPS FLAT WASHER HEAD  
SHEET METAL SCREW  
POZIDRIVE  
NICKEL/ BLACK  
UNIT PKG.-50

**2226**

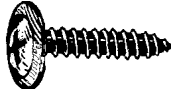

(OE-11501884)  
PHILLIPS FLAT WASHER  
HEAD SCREW  
4.2 MM X 20 MM-POZIDRIVE  
(7/16" WASHER)  
GM & UNIVERSAL  
BLACK  
UNIT PKG.-100

**2881**



(GM-11514281)  
4.2-1.41 X 25 MM  
(11 MM WASHER O.D.)  
PHILLIPS FLAT WASHER HEAD  
SHEET METAL SCREW  
BLACK  
UNIT PKG.-100

**2777**

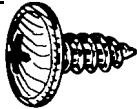

4.8-1.59 X 15 MM (#10 X 5/8")  
PHILLIPS WASHER HEAD  
(14 MM WASHER O.D.)  
SHEET METAL SCREW-AB  
NISSAN BUMPER &  
UNIVERSAL-BLACK  
UNIT PKG.-50

**2778**

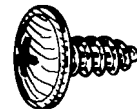

6.3-1.81 X 16 MM (#14 X 5/8")  
PHILLIPS WASHER HEAD  
(15.5 MM WASHER DIAM.)  
SHEET METAL SCREW-AB  
JAPANESE CARS & UNIVERSAL- BLACK  
UNIT PKG.-50

## SHEET METAL SCREWS-BLACK

### ROUND (FLAT TOP) WASHER HEAD SHEET METAL SCREWS- AB-BLACK



<u>PART #</u>	<u>OE #</u>	<u>DESCRIPTION</u>	<u>UPKG.</u>
2325	(FORD-56901-S2) (GM-11503569)	4.2 X 10 MM (#8 X 3/8") (25/64" WASHER O.D.) POZI DRIVE	100
2585	(FORD-56902-S2)	#8 X 1/2" (3/8" WASHER O.D.)	100
2227	(FORD-56902) (GM-11501896)	4.2 X 13 MM(#8 X 1/2") (21/64" WASHER O.D.) POZI DRIVE	100
2665	(GM-11503421) (CHRYSLER-9422202)	4.2 X 13 MM (#8 X 1/2") POZIDRIVE (10 MM/25/64" WASHER O.D.)	100
3256	(FORD-59303-S2)	#8-18-5/8" (3/8" WASHER O.D.)	100
2787	(FORD-56912-S2)	#8-18 X 3/4" (1/2" WASHER O.D.)	100
2345	(CHRYSLER 9428738, 6032723) (FORD-56904-S2)(GM-11504766)	#8-15 X 3/4" (13/32" WASHER O.D.)	100
3255		#8-18 X 3/4" (3/8" WASHER O.D.)	100
2840	(FORD-56913-S2)	#8-18 X 7/8" (1/2" WASHER O.D.)	100
2575	(GM-11509237)	#8 X 1"(4.2 X 25MM) (11/32" WASHER O.D.) POZI DRIVE	100
2623		#8 X 1" (27/64" WASHER O.D.)	100
2841	(FORD-56914-S2)	#8-18 X 1" (1/2" WASHER O.D.)	100
2788	(FORD-56915-S2)	#8 X 1-1/4" (1/2" WASHER O.D.)	50
2586	(FORD-56916-S2)	#8 X1-1/2" (1/2" WASHER O.D.)	50
2921		#10-16 X 3/4" (1/2" WASHER O.D.)	50
2922		#10-16 X 1" (1/2" WASHER O.D.)	50

## SHEET METAL SCREWS-BLACK

### PHILLIPS OVAL HEAD- A



<u>PART</u>	<u>SIZE</u>	<u>UPKG.</u>
673	#8 X 1/2" (#6 HD)	100
2331	#8 X 1/2"	100
674	#8 X 3/4" (#6 HD)	100
2332	#8 X 3/4"	100
675	#8 X 1" (#6 HD)	100
2333	#8 X 1"	100
676	#8 X 1-1/4" (#6 HD)	100
2334	#8 X 1-1/4"	100
2762	#8 X 1-1/2"	100
	(11503555) (4.2-1.41X 40MM)	
2715	#8 X 2-1/2" (#6 HD)	50
2335	#10 X 3/4"	100
2149	#10 X 1"	100
2743	#10 X 1" (#8 HD)	100

### PHILLIPS PAN HEAD- AB



<u>PART #</u>	<u>SIZE</u>
2742	#6 X 1"
2838	#8 X 3/8" (OE-55926-S424)
2148	#8 X 1/2"
2319	#8 X 3/4"(type A)
2320	#8 X 1"
2839	#8 X 1-1/4" (OE-55930-S2)
2804	#10 X 1/2" (OE-154804)
2805	#10 X 5/8" (OE-6032899,W504262)
2424	#10 X 3/4"
2401	#10 X 1"
2905	#14 X 1" (6.3 X 25 MM) (OE-11514331)

EACH UNIT PKG.-100

### PHILLIPS OVAL HEAD FINISHING SCREWS-SEMS- AB-BLACK (All #6 Head)



<u>PART #</u>	<u>SIZE</u>	<u>WASHER TYPE</u>	<u>UPKG.</u>
2343	#8 X 1/2"	FLUSH	50
2344	#8 X 3/4"	FLUSH	50
2296	#8 X 3/4"	COUNTERSUNK	100
2297	#8 X 1"	COUNTERSUNK	100
2528	#10 X 3/4"	COUNTERSUNK	50
2529	#10 X 1"	COUNTERSUNK	50

## 2685



#8 X 1/2" SELF DRILLING  
SHEET METAL SCREW  
PHILLIPS ROUND  
WASHER HEAD  
(3/8" WASHER O.D.)  
BLACK OXIDE

UNIT PKG.-100

## 2340



#8 X 1/2" PHILLIPS FLAT WASHER HEAD SCREW-SELF DRILLING  
(4.2MM X 13MM), (7/16" WASHER O.D.)  
GM, FORD, CHRYSLER, FOREIGN & UNIVERSAL  
ZINC/BLACK  
UNIT PKG.-100

## SHEET METAL SCREWS-BRIGHT

### PHILLIPS OVAL HEAD NICKEL PLATED-A



<u>PART NO.</u>	<u>SIZE</u>	<u>UNIT PACKAGE</u>
629	#4 X 3/4"	100
627	#6 X 3/4"	100
628	#6 X 1"	100
2410	#8 X 3/8" (#6 HD)	100
631	#8 X 1/2"	100
2411	#8 X 1/2" (#6 HD)	100
633	#8 X 5/8" (#6 HD)	100
635	#8 X 3/4"	100
636	#8 X 1" (#6 HD)	100
637	#8 X 1"	100
638	#8 X 1-1/4"	100
639	#8 X 1-1/4" (#6 HD)	100
641	#8 X 1-3/4" (#6 HD)	100
643	#8 X 2" (#6 HD)	100
646	#8 X 2-1/2" (#6 HD)	50
654	#10 X 3/4"	100
2597	#10 X 3/4" (#6 HD)	100
655	#10 X 3/4" (#8 HD)	100
656	#10 X 1"	100
657	#10 X 1-1/4" (#6 HD)	100
658	#10 X 1" (#6 HD)	100
659	#10 X 1" (#8 HD)	100
660	#10 X 1-1/2" (#6 HD)	100
2412	#10 X 1-3/4" (#6 HD)	100
663	#10 X 2-1/2" (#8 HD)	50
670	#12 X 1"	100

### PHILLIPS PAN HEAD-ZINC-A/AB



<u>PART NO.</u>	<u>SIZE</u>	<u>UNIT PACKAGE</u>
680	#6 X 1/2"	100
2389	#6 X 1"	100
682	#8 X 1/2"	100
2390	#8 X 3/4"	100
2802	#8 X 3/4"	50
(CHROME PLATED WITH SEALER)		
3115	#8 X 3/4"	100
(OE-11501929) (CHROME PLATED)		
667	#8 X 1"	100
2454	#8 X 1"	100
(CHROME PLATED)		
2260	#8 X 1-1/8" (#6 HD.)	100
(CHROME PLATED)		
2781	#10 X 3/8"	100
(4.8 X 9.5MM) POZIDRIVE (OE-W504260) ZINC/YELLOW		
684	#10 X 1/2"	100
685	#10 X 5/8"	100
686	#10 X 3/4"	100
689	#10 X 1"	100
2391	#10 X 1-1/2"	100
3096	#10 X 1-3/4"	100
2392	#10 X 2"	100
687	#12 X 1/2"	100
2393	#12 X 3/4"	100
2394	#12 X 1"	100
2395	#12 X 1-1/2"	100
2396	#14 X 3/4"	100
2397	#14 X 1"	100
683	#14 X 1-3/4"	50

### PHILLIPS FLAT HEAD NICKEL PLATED-A



<u>PART NO.</u>	<u>SIZE</u>	<u>UNIT PACKAGE</u>
620	#6 X 3/8" (#5 HD)	100
621	#6 X 1/2"	100
622	#8 X 3/8" (#5 HD) (ZINC PLATED)	100

### SLOTTED PAN HEAD-ZINC PLATED-A



<u>PART NO.</u>	<u>SIZE</u>	<u>UNIT PACKAGE</u>
501	#6 X 3/8"	100
505	#6 X 1"	100
509	#8 X 3/8"	100
537	#14 X 3/4"	100

## SHEET METAL SCREWS-BRIGHT

**PHILLIPS OVAL FINISHING SEMS-AB  
SHEET METAL SCREWS-CHROME PLATED  
COUNTERSUNK WASHER (All #6 Head)**



<u>PART #</u>	<u>SIZE</u>
1651	#8 X 5/8"
1652	#8 X 3/4"
1653	#8 X 1"
1659	#10 X 1"

EACH NUMBER UNIT PKG.-100

**PHILLIPS OVAL CHROME  
SHEET METAL SCREWS**



<u>PART #</u>	<u>SIZE</u>	<u>UPKG.</u>
2498	#8 X 3/4" (#6 HD.)-AB	100
2499	#8 X 3/4"-A	100
2500	#8 X 1" (#6 HD.)-AB	100
2763	#8 X 1"-AB (OE-11501867)	100
2513	#8 X 1-1/4" (#6 HD.)-A	100
2501	#8 X 1-1/2" (#6 HD.)-A	100

### METRIC TORX HEAD TAPPING SCREWS-AB



<u>PART #</u>	<u>SIZE</u>	<u>HEAD STYLE</u>	<u>OE NUMBER</u>	<u>FINISH</u>	<u>UPKG.</u>
2744	4.2 X 13MM	PAN	11504646	BRIGHT	50
2745	4.2 X 16MM	PAN	11508879	BLACK	50
2184	4.2 X 20MM	OVAL	11504069	CHROME	50
2185	4.2 X 20MM	OVAL	11504659	BLACK OXIDE	50
2186	4.2 X 20MM	PAN	11504647	CHROME	50
2187	4.2 X 20MM	PAN	11504665	BLACK OXIDE	50
2746	4.2 X 20MM	PAN	11505204	BLACK	50
3314	4.2 X 30MM	OVAL	11504522	CHROME	50
				(STAINLESS STEEL)	
2189	4.2 X 30MM	OVAL	11504656	BLACK OXIDE	50
2240	4.2 X 50MM	PAN	11504654	BLACK OXIDE	25
3236	#10-16 X 3/4"	PAN	6034912	BLACK	100

### SHEET METAL SCREWS STAINLESS STEEL

**3052**



6-2.54 X 16 MM (#14 X 5/8")  
PHIL. OVAL HEAD  
SHEET METAL SCREW  
TYPE "A"  
STAINLESS STEEL-BLACK  
UNIT PKG.-50

**2842**



#8 X 1"  
PHIL. OVAL HEAD  
SHEET METAL SCREW-TYPE "AB"  
STAINLESS STEEL  
CHROME  
UNIT PKG.-50

**2843**



#8 X 1-1/2"  
PHIL. OVAL HEAD  
SHEET METAL SCREW  
TYPE "AB"  
STAINLESS STEEL  
CHROME  
UNIT PKG.-50

## SHEET METAL SCREWS - SELF DRILLING

**UNSLOTTED HEX WASHER HEAD  
SELF DRILLING, SELF TAPPING  
ZINC PLATED**



<u>PART #</u>	<u>SIZE</u>	<u>UPKG.</u>
2409	#8 X 1/2"	100
2150	#8 X 3/4"	100
2659	#8 X 1"	100
2620	#10 X 1/2"	100
2660	#10 X 3/4"	100
2275	#10 X 1"	50
2764	#12 X 3/4"	100
2765	#14 X 3/4"	100
2486	#14 X 1"	25
3068	#14 X 1-1/4"	25
3069	#14 X 1-1/2"	25

**PHILLIPS OVAL HEAD-SELF DRILLING  
FINISHING SCREWS WITH LOOSE  
COUNTERSUNK WASHER**

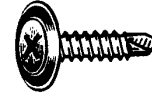

<u>PART #</u>	<u>SIZE</u>	<u>FINISH</u>
2996	#8 X 3/4"	CHROME
2997	#8 X 3/4"	BLACK
2998	#8 X 1"	CHROME
2999	#8 X 1"	BLACK
3000	#10 X 1"	CHROME
3001	#10 X 1"	BLACK

EACH NUMBER UNIT PKG.-50

**PHILLIPS PAN HEAD  
SELF DRILLING POINT  
ZINC**

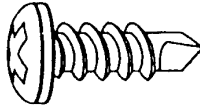

<u>PART #</u>	<u>SIZE</u>	<u>UPKG.</u>
2657	#8 X 1/2"	100
2658	#8 X 1"	100

**PHILLIPS FLAT TOP  
WASHER HEAD  
SELF DRILLING-BLACK  
( 11 MM WASHER DIAM.)**

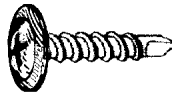

<u>PART #</u>	<u>SIZE</u>	<u>UPKG.</u>
2796	4.2 X 16	100
2797	4.2 X 19	100
2798	4.2 X 25	100

**PHILLIPS OVAL HEAD-SELF DRILLING  
FINISHING SCREWS  
WITH LOOSE FLUSH-TYPE WASHER**



2463-4.2 x 20 MM -ZINC(OE11502470)  
(NOTE: 4.2 X 20MM = #8 X 3/4")  
2484-4.2 X 20 MM-BLACK(OE11509707)  
2733- #8 X 1-1/2" (#6 HD.)- BLACK  
2734- #8 X 1-1/2" (#6 HD.)- ZINC  
2735- #10 X 3/4" (#6 HD.)- BLACK  
2736- #10 X 3/4" (#6 HD.)- ZINC  
2738- #10 X 1" (#6 HD.)- ZINC

EACH NUMBER UNIT PKG.-50

**2482**



(9436165)

#8 X 7/8" PHILLIPS ROUND WASHER HEAD SCREW  
(13/32" WASHER O.D.)  
TEKS POINT-ZINC, CHRYSLER & UNIVERSAL  
UNIT PKG.-100

**3015**



4.2-1.41 X 20 MM INDENTED  
HEX WASHER HEAD SELF  
DRILLING SCREW WITH ATTACHED 12 MM  
LOOSE WASHER; 7 MM HEX; -BLACK  
UNIT PKG.-50

**3016**

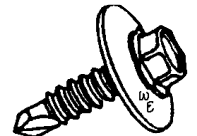

4.2-1.41 X 20 MM INDENTED HEX  
WASHER HEAD SELF DRILLING  
SCREW WITH ATTACHED 16 MM  
LOOSE WASHER; 7 MM HEX; -BLACK  
UNIT PKG.-50



## SHEET METAL SCREWS

### HEX HEAD-A ZINC PLATED



<u>PART #</u>	<u>SIZE</u>	<u>UPKG.</u>
575	#8 X 1/2"	100
593	#10 X 1-1/2" (5/16" HD)	100
579	#12 X 3/4"	100
580	1/4" X 3/4" (7/16" HD)	100
582	1/4" X 1" (7/16" HD)	100
586	1/4" X 1-1/2" (7/16" HD)	100
587	#14 X 2" (3/8" HD)	100
588	5/16" X 3/4" (1/2" HD)	50
590	5/16" X 1" (1/2" HD)	50

### UNSLOTTED HEX WASHER HEAD-AB BLACK

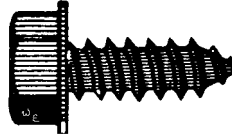

<u>PART #</u>	<u>DESCRIPTION</u>	<u>UPKG.</u>
2488	4.2 X 20 MM (7MM HEX) (9MM WASHER;OE-11503552, 11502836, 11509737)	100
598	#14X 5/8" (3/8" HD)	100
596	5/16" X 5/8"	50
597	5/16" X 7/8"	50

### SLOTTED HEX WASHER HEAD-AB ZINC PLATED



<u>PART #</u>	<u>SIZE</u>	<u>UPKG.</u>
601	#8 X 3/8"- 1/4" HD A/F	100
602	#8 X 3/4"- 1/4" HD A/F	100
605	#10 X 3/8"- 5/16" HD A/F	100
599	#10 X 5/8"- 5/16" HD A/F	100
603	#10 X 1"- 5/16" HD A/F	100
2203	#14 X 3/4"- 3/8" HD A/F	50

### UNSLOTTED HEX WASHER HEAD-A ZINC PLATED

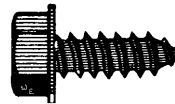

<u>PART #</u>	<u>DESCRIPTION</u>	<u>UPKG.</u>
2520	#8 X 3/8" (1/4" HD-A/F) (OE-9415191) ( 21/64" WASHER O.D.)	100
2783	4.2 X 13MM ( 7MM HEX) (OE-11509185) (STAINLESS STEEL; 9MM WASHER O.D.)	50
2803	#10 X 5/8" (3/32" HEAD) (OE-9417855)	100
2591	#10 X 1-1/2" (5/16" HD A/F) (13/32" WASHER O.D.)	100

2519  
(6033006)













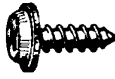

#10 X 5/8" UNSLOTTED HEXWASHER HD  
SCREW W/SEALER(5/16" HEX; 7/16" WASHER)  
CHRYSLER & UNIVERSAL  
BLACK PHOSPHATE  
UNIT PKG.-50

2271  
(OE-943355)

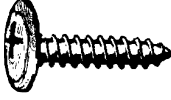

#10 X 3/4"  
HEX WASHER HEAD THREAD CUTTING SCREW-TYPE 25  
FRONT FASCIA, HDLMP&GRILLE MOUNTING  
CHRYSLER-BLACK  
UNIT PKG.-50

## SHEET METAL SCREWS

<p><b>625</b> </p> <p>#8 X 3/8" (#6 HEAD) (3/8" WASHER DIAMETER) PHILLIPS OVAL WSHR HEAD SELF TAPPING SCREW WHEEL OPENING MOULDING SCREW UNIVERSAL ZINC UNIT PKG.-100</p>	<p><b>671</b> </p> <p>#5-20 X 3/8" (7/32" HEAD) PHILLIPS FLAT HD SCREW USE WITH PLASTIC MOULDING CLIPS, LANDAU CLIPS (W&amp;E #345) UNIVERSAL ZINC UNIT PKG.-100</p>	<p><b>672</b> </p> <p>#8 X 3/8" SCREW FOR ATTACHING WINDSHIELD &amp; REAR WINDOW REVEAL MOULDING CLIPS (LOW PROFILE HEAD) CHRYSLER &amp; UNIVERSAL- ZINC UNIT PKG.-100</p>
<p><b>2222</b> </p> <p>(6030539), (9616231) (38439 S47) #8 X 1/2" (3/8" WASHER DIAMETER) PHILLIPS OVAL WASHER HEAD SELF DRILLING SCREW WHEEL OPENING MOULDING SCREW GM &amp; UNIVERSAL ZINC UNIT PKG.-100</p>	<p><b>2259</b> </p> <p>(11501794) 4.2 X 12 MM (#8 X 1/2") (25/64" WASHER DIAM.) PHILLIPS OVAL WASHER HEAD SCREW BODY SIDE MOULDING SCREW/ FRONT END ORNAMENT, WHEELHOUSE CHROME PLATED UNIT PKG.-100</p>	<p><b>2403</b> </p> <p>#8 X 1/2" PHILLIPS ROUND WASHER HEAD SHEET METAL SCREW WITH SEALER (23/64" WASHER OD) ZINC UNIT PKG.-50</p>
<p><b>2382</b> </p> <p>#8 X 1/2" PHILLIPS TRUSS HEAD (TYPE 17 PT.) THREAD CUTTING WHEELHOUSE SCREW ZINC UNIT PKG.-100</p>	<p><b>2404</b> </p> <p>#10 X 1/2" PHILLIPS ROUND WASHER HEAD SHEET METAL SCREW WITH SEALER (27/64" WASHER OD) ZINC UNIT PKG.-50</p>	<p><b>2341</b> </p> <p>4.2 X 20 MM ( #8 X 3/4") PHILLIPS FLAT WASHER HEAD SCREW (7/16" WASHER OD) ZINC UNIT PKG.-100</p>
<p><b>2860</b> </p> <p>(REPLACES GM-11501883) PHILLIPS FLAT WASHER HEAD, SHEET METAL SCREW-AB POZIDRIVE 4.2 X 13 MM (#8 X 1/2")-11 MM WASHER DIAMETER ZINC UNIT PKG.-100</p>	<p><b>2450</b> </p> <p>#8 X 5/16" PHILLIPS ROUND WASHER HEAD SCREW (27/64" WASHER OD) CHROME PLATED UNIT PKG.-100</p>	<p><b>2447</b> </p> <p>#6 X 1/2" PHILLIPS FLAT HEAD SCREW (#4 HEAD SIZE)-ZINC UNIT PKG.-100</p>

## CLIP NUTS

**2346**



"U" TYPE CLIP NUT  
#6 SCREW SIZE  
GENERAL PURPOSE-BLACK  
PANEL RANGE-.025-.150"  
UNIT PKG.-50

**811**

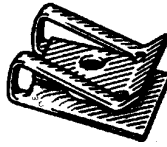

"U" TYPE CLIP NUT  
#8 SCREW SIZE  
GENERAL PURPOSE  
PANEL RANGE-.025-.150"  
UNIT PKG.-50

**814**

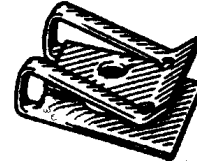

"U" TYPE CLIP NUT  
#14 SCREW SIZE  
GENERAL PURPOSE  
PANEL RANGE-.025-.150"  
UNIT PKG.-50

**846**



"U" TYPE CLIP NUT  
#8A SCREW SIZE  
GENERAL PURPOSE  
PANEL RANGE-.055-.080"  
UNIT PKG.-100

**858**



"U" TYPE CLIP NUT  
#10A SCREW SIZE  
GENERAL PURPOSE  
PANEL RANGE-.025-.064"  
UNIT PKG.-100

**859**



"U" TYPE CLIP NUT  
#10A SCREW SIZE  
HEADLAMP TO FENDER  
PANEL RANGE-.025-.040"  
BUICK  
UNIT PKG.-50

**852**

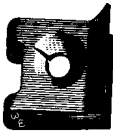

"U" TYPE CLIP NUT  
#8A SCREW SIZE  
HEADLAMP TO FENDER  
PANEL RANGE-.025-.040"  
FORD  
UNIT PKG.-100

**853**

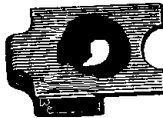

"J" TYPE CLIP NUT  
#8A SCREW SIZE  
FRONT FENDER ASSEMBLY  
AND HEADLAMP TO FENDER  
PANEL RANGE-.025-.040"  
FORD  
UNIT PKG.-50

**855**

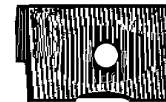

"J" TYPE CLIP NUT  
#10A SCREW SIZE  
HEADLAMP TO FENDER  
PANEL RANGE-.027-.045"  
CHEVY  
UNIT PKG.-50

**860**



"J" TYPE CLIP NUT  
#14A (1/4") SCREW SIZE  
FRONT END ASSEMBLY  
PANEL RANGE-.051-.062"  
GM, CHRYSLER, FORD  
UNIT PKG.-100

**861**







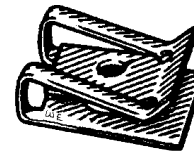

"U" TYPE CLIP NUT  
#1/4-20 SCREW SIZE  
LICENSE PLATE  
PANEL RANGE-.064-.125"  
ALL CARS  
UNIT PKG.-100

**2164**

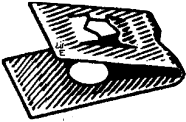

"U" TYPE CLIP NUT  
#10A SCREW SIZE  
GENERAL PURPOSE  
WIDE PANEL RANGE  
PANEL RANGE-.025-.150"  
UNIVERSAL  
UNIT PKG.-50

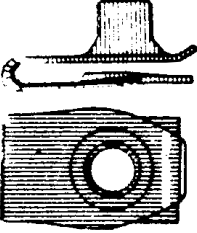
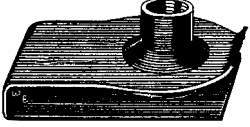
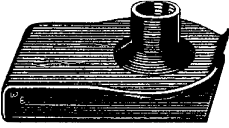
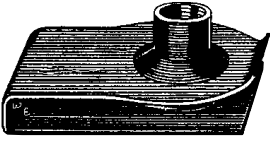
## CLIP NUTS & USS FOLD OVER NUTS

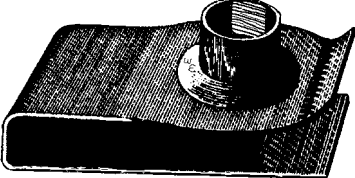
<p><b>2220</b></p>  <p>(10005510) CLIP NUT BUMPER IMPACT STRIP PONTIAC- '78 &amp; UP GM "X" CARS- '80 &amp; UP UNIT PKG.-50</p>	<p><b>2255</b></p>  <p>(9433155) "U" TYPE CLIP NUT LONG THROAT, WIDE RANGE #8A OR 4.2 MM SCREW SIZE PANEL RANGE-.025-.150" GM, FORD &amp; UNIVERSAL UNIT PKG.-50</p>	<p><b>2708</b></p>  <p>(9433159) "U" TYPE CLIP NUT #14 SCREW SIZE WIDE RANGE (.125-.250") GM &amp; UNIVERSAL UNIT PKG.-50</p>
<p><b>2751</b></p>  <p>(N 802538-S301) SPECIAL CLIP NUT #8 SCREW SIZE 1/16"- 5/32" PANEL RANGE FORD TAURUS/ WINDSTAR SILVER DACROMET PLATING UNIT PKG.-50</p>	<p><b>910</b> (FORD- 45263-S2)</p>  <p>1/4-20 USS "U" TYPE SPEED NUT SHORT THROAT GENERAL PURPOSE PANEL RANGE-.06-.09" UNIT PKG.-50</p>	<p><b>911</b></p>  <p>(45267) 1/4"-20 USS "U" TYPE SPEED NUT LONG THROAT GENERAL PURPOSE PANEL RANGE-.025-.150" UNIT PKG.-50</p>
<p><b>915</b></p>  <p>(GM-1494253) (FORD-45264-S2) 5/16"-18 USS "U" TYPE SPEED NUT GENERAL PURPOSE PANEL RANGE-.025-.150" UNIT PKG.-25</p>	<p><b>916</b></p>  <p>(1494258) 5/16"-18 USS "U" TYPE SPEED NUT LONG THROAT GENERAL PURPOSE PANEL RANGE-.025-.150" UNIT PKG.-25</p>	<p><b>2926</b></p>  <p>(CHRYSLER-6023168) "J" TYPE SPEED NUT 1/4-20 USS THREAD, 1/2" THROAT .04-.08" PANEL THICKNESS GENERAL PURPOSE UNIT PKG.-50</p>
<p><b>917</b></p>  <p>(FORD-45269) 3/8"-16 USS "U" TYPE NUT LONG THROAT PANEL RANGE-.050-.200" CENTER HOLE TO EDGE- 1-1/8" UNIT PKG.-10</p>	<p style="text-align: center;">CONTACT US WITH ANY QUESTIONS OR SUGGESTIONS VIA PHONE, FAX OR EMAIL</p> <p style="text-align: center;">VISIT US ON OUR WEBSITE AT:  <b>WWW.WESALES.COM</b></p>	

## METRIC FOLD OVER NUTS-OEM & UNIVERSAL

**5901**

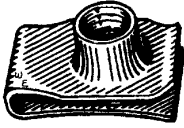

(11500658)  
(11502785)  
6.3-1.0 MM FOLDOVER NUT  
GM CARS - '77 & UP  
UNIT PKG.-50

**5902**

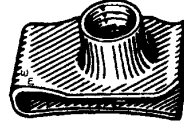

(GM-11508925), (GM-11500660)  
(FORD-N623333-S2, N623333-S100)  
8-1.25 MM METRIC FOLDOVER NUT  
GM, FORD & UNIVERSAL  
UNIT PKG.-25

**5903**

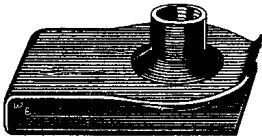

(11500661)  
8-1.25 MM LONG THROAT METRIC  
FOLDOVER NUT  
GM- '77 & UP- UNIVERSAL  
UNIT PKG.-25

**5904**

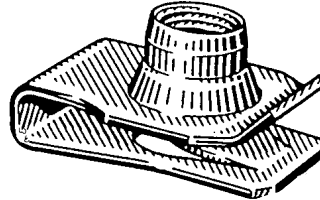

(11500662)  
10-1.5 MM METRIC SPEED NUT  
GM- '77 & UP- UNIVERSAL  
UNIT PKG.-25

**5920**

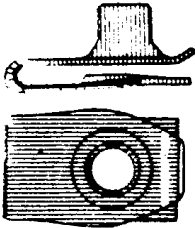

(1016937, 11503957, N623332)  
6-1.0 MM METRIC SPEED NUT  
LONG THROAT  
GM- '79 & UP  
FORD & UNIVERSAL  
UNIT PKG.-50

**5924**

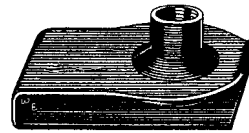

(11506099, 11503715, 11508241)  
6-1.0 MM METRIC SPEED NUT  
LONG THROAT  
GM- "X" & "J" CARS &  
UNIVERSAL  
UNIT PKG.-25

**5936**

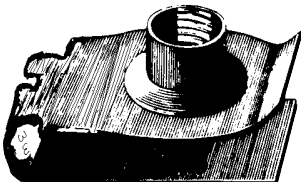



(6500626)  
10-1.5 MM "U" NUT -"HEAVY DUTY"  
ENGINE SUPPORT TO FRONT SIDE RACK  
CHRYSLER & UNIVERSAL  
UNIT PKG.-10

**5989**



(GM-11500656, 11505596)  
(FORD-N623331-S2)  
(CHRYSLER-6100040)  
M5-0.8 METRIC FOLDOVER NUT  
(0.6-3.8 MM PANEL RANGE)  
(11.5 MM THROAT)  
UNIT PKG.-25

## METRIC BODY BOLTS-OEM & UNIVERSAL

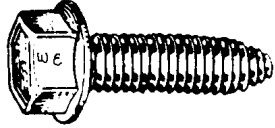
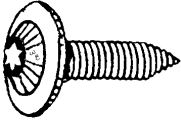
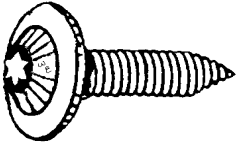
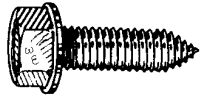
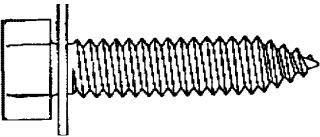
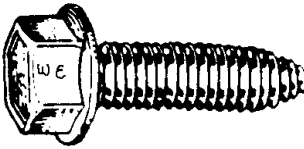
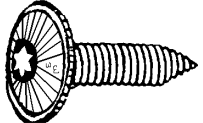
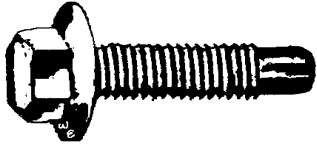
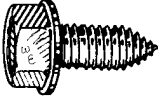
<p><b>3088</b></p>  <p>(GM 20033049) 8-1.25 X 35 MM INDENTED HEX WASHER HEAD BOLT 13 MM HEX 17 MM WASHER CAPTIVE POINT UNIT PKG.-25</p>	<p><b>5905</b></p>  <p>(11500961) 6.3-1.0 X 20 MM HEX WASHER HEAD BODY BOLT- CA PT. 10 MM HEX 13 MM WASHER GM &amp; UNIVERSAL '77 &amp; UP UNIT PKG.-50</p>	<p><b>5906</b></p>  <p>(11500970) (11503632)</p> <p>8-1.25 X 25 MM BODY BOLT HEX WASHER HEAD; CA POINT 13 MM HEX 16 MM WASHER O.D. GM &amp; UNIVERSAL- '77 &amp; UP UNIT PKG.- 50</p>
<p><b>5953</b></p>  <p>6-1.0 X 20 MM TORX WASHER HEAD BODY BOLT- CA POINT 18 MM WASHER ZINC UNIT PKG.- 25</p>	<p><b>5954</b></p>  <p>6-1.0 X 30 MM TORX WASHER HEAD BODY BOLT- CA POINT 18 MM WASHER ZINC UNIT PKG.- 25</p>	<p><b>5967</b></p>  <p>(11503800) 6-1.0 X 20 MM HEX WASHER HEAD BODY BOLT- CA PT. 10 MM HEX 13 MM WASHER GM &amp; UNIVERSAL '77 &amp; UP UNIT PKG.-50</p>
<p><b>5980</b></p>  <p>(11515425) 8-1.25 X 35 MM INDENTED HEX HEAD BODY BOLT 17 MM LOOSE WASHER 13 MM HEX; CA POINT GM &amp; UNIVERSAL-BLACK UNIT PKG.-25</p>	<p><b>5985</b></p>  <p>10-1.5 X 30 MM HEX WASHER HEAD BODY BOLT-CA POINT (15 MM HEX; 19 MM WASHER) BLACK UNIT PKG.-25</p>	<p><b>5987</b></p>  <p>6-1.0 X 20 MM TORX WASHER HEAD BOLT-CA POINT 16 MM WASHER O.D. BLACK UNIT PKG.-25</p>
<p><b>5988</b></p>  <p>(11515791) 8-1.25 X 35 MM HEX FLANGE HEAD (13 MM HEX; 17.5 MM FLANGE O.D.) BODY BOLT-DOG POINT GRADE 10.9 UNIT PKG.-15</p>	<p><b>3258</b></p>  <p>(16600199) 6-1.0 X 13 MM INDENTED HEX WASHER HEAD BODY BOLT-CA POINT (10 MM HEX; 13 MM WASHER O.D.) GM-ZINC UNIT PKG.- 50</p>	<p style="text-align: center;">PLEASE CONTACT US WITH ANY NEW PARTS &amp; ASSORTMENTS VIA EMAIL, PHONE OR FAX</p> <p style="text-align: center;"><a href="http://WWW.WESALES.COM">WWW.WESALES.COM</a></p>

## METRIC BODY BOLTS-OEM & UNIVERSAL

**3053**

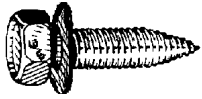

(11509440)  
6-1.0 X 20 MM  
UNSLOTTED HEX HD BODY BOLT  
(12 MM LOOSE WSHR; 10 MM HEX)  
CA POINT; GM  
BLACK  
UNIT PKG.-25

**5947**

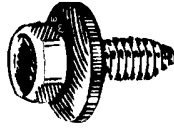

(11503941), (11503823)  
6-1.0 X 20 MM BODY BOLT  
INDENTED HEX HEAD  
(17 MM LOOSE WSHR; 10MM HEX)  
CA POINT- UNIVERSAL  
GM-'82 & UP  
UNIT PKG.-25

**5976**

(11509033)

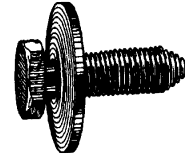

6-1.0 X 20 MM BODY BOLT  
INDENTED HEX HEAD  
(24 MM WASHER; 10 MM HEX)  
CA POINT -BLACK  
GM & UNIVERSAL  
UNIT PKG.- 25

**5923**

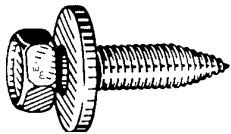

(11503834), (20351035)  
6-1.0 X 25 MM BODY BOLT  
INDENTED HEX HD; (17 MM LOOSE  
WASHER; 10 MM HEX) CA POINT  
(SMALLER WASHER THAN 5921)  
GM, HONDA, NISSAN & TOYOTA  
UNIT PKG.-25

**5921**

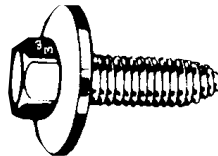

(11503982), (11504493)  
6-1.0 X 25 MM BODY BOLT  
INDENTED HEX HD WITH  
24 MM LOOSE WASHER  
CA POINT  
GM & UNIVERSAL  
UNIT PKG.-25

**5962**

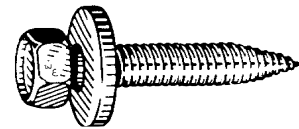

(11505044)  
6-1.0 X 35 MM BODY BOLT  
INDENTED HEX HEAD  
17 MM WASHER; 10 MM HEX  
CA POINT  
GM & UNIVERSAL  
UNIT PKG.- 25

**5927**

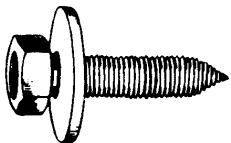

(11502970)  
6.3-1.0 X 25 MM BODY BOLT  
INDENTED HEX HEAD  
WITH 16.5 MM LOOSE WASHER  
CA POINT  
GM-'77 & UP AND UNIVERSAL  
UNIT PKG.-50

**5910**

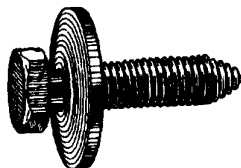

(11501188)  
8-1.25 X 30 MM BODY BOLT  
INDENTED HEX HEAD  
WITH 24 MM LOOSE WASHER  
CA POINT  
GM-'77 & UP AND UNIVERSAL  
UNIT PKG.-25

**5955**

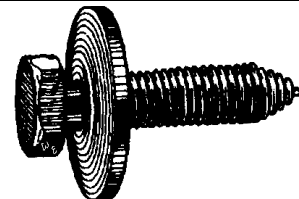

(11501189)  
8-1.25 X 35 MM BODY BOLT  
INDENTED HEX HEAD WITH 24  
MM LOOSE WASHER; CA POINT  
GM AND UNIVERSAL  
BLACK  
UNIT PKG.-15

**5932**

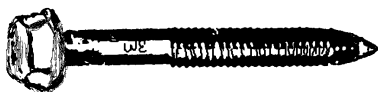

(PICTURE NOT ACTUAL SIZE)  
(6500369)  
8-1.25 X 55 MM BODY BOLT  
HEX WASHER HEAD; CA POINT  
CHRYSLER AND UNIVERSAL  
UNIT PKG.-10

**5911**

(11501193)

10-1.50 X 40 MM BODY BOLT  
INDENTED HEX HEAD  
(15 MM HEX) WITH 28 MM LOOSE WASHER  
CA-POINT  
GM-'77 & UP AND UNIVERSAL  
UNIT PKG.-15

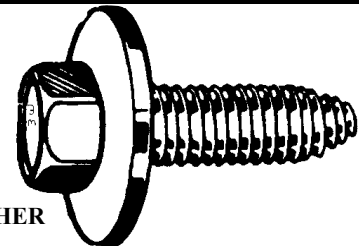

## METRIC BODY BOLTS-OEM & UNIVERSAL

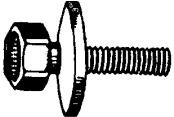
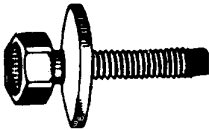
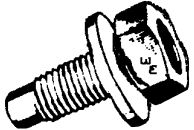
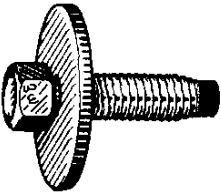
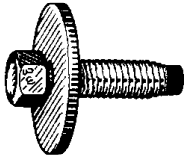
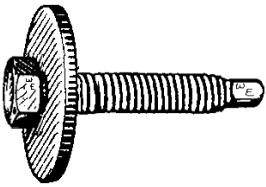
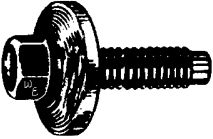
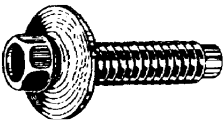
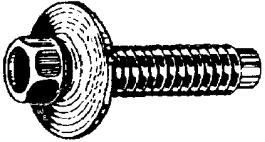
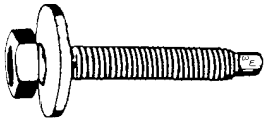
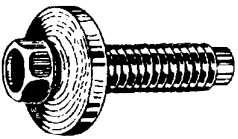
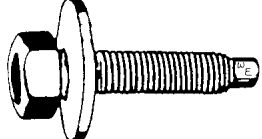
<p><b>5986</b></p>  <p>(10060375) 5-0.8 X 16 MM BODY BOLT INDENTED HEX HEAD 20 MM WASHER; 10 MM HEX-BLACK GM &amp; UNIVERSAL UNIT PKG.- 25</p>	<p><b>5940</b></p>  <p>6-1.0 X 20 MM BODY BOLT INDENTED HEX HEAD WITH LOOSE WASHER 10 MM HEX; 17 MM WASHER DIAM. DOG POINT UNIT PKG.-25</p>	<p><b>5939</b></p>  <p>8-1.25 X 20 MM BODY BOLT INDENTED HEX HEAD 19 MM (3/4") WASHER DOG POINT GM &amp; UNIVERSAL UNIT PKG.- 25</p>
<p><b>3102</b></p>  <p>6-1.0 X 20 MM UNSLOTTED INDENTED HEX HEAD BOLT WITH 24 MM LOOSE WASHER 8 MM HEAD- DOG POINT SILVER DACROMET UNIT PKG.-25</p>	<p><b>3120</b></p>  <p>(GM-11516908) 6-1.0 X 20 MM HEX HEAD BODY BOLT 24 MM LOOSE WASHER 10 MM HEX; DOG POINT ZINC/ OLIVE PLATING UNIT PKG.-25</p>	<p><b>3259</b></p>  <p>6-1.0 X 30 MM INDENTED HEX BOLT (10 MM HEX) WITH 24 MM LOOSE WASHER DOG POINT (THREAD STARTER) BLACK UNIT PKG.- 25</p>
<p><b>5963</b></p>  <p>FORD-(N606676-S2) 6-1.0 X 22 MM BODY BOLT INDENTED HEX HEAD 8 MM HEX 19 MM (3/4") WASHER DOG PT FORD, CHRYSLER &amp; UNIVERSAL UNIT PKG.- 50</p>	<p><b>3089</b></p>  <p>(GM 11515655) 6-1.0 X 25 MM HEX HEAD BOLT WITH 17 MM LOOSE WASHER; 10 MM HEX GM- BLACK UNIT PKG.-25</p>	<p><b>3054</b></p>  <p>(FORD W503925-S36) 6-1.0 X 25 MM UNSLOTTED HEX HEAD BODY BOLT WITH 19 MM LOOSE WASHER; (8 MM HEX) DOG POINT ZINC/YELLOW UNIT PKG.-50</p>
<p><b>3319</b></p>  <p>(W505416) 5-0.8 X 25 MM INDENTED HEX HEAD BOLT (8 MM HEX) WITH 14.5 MM ATTACHED LOOSE WASHER PILOT POINT FORD &amp; UNIVERSAL BLACK UNIT PKG.-25</p>	<p><b>5952</b></p>  <p>(N606677-S36) 6-1.0 X 28 MM BODY BOLT INDENTED HEX HEAD (8 MM HEX) WITH 19 MM LOOSE WASHER DOG POINT-ZINC/YELLOW PLATED; -FORD UNIT PKG.-25</p>	<p><b>5968</b></p>  <p>(6100568) 6-1.0 X 30 MM BODY BOLT INDENTED HEX HEAD (10 MM HEX); (19 MM LOOSE WASHER) DOG POINT-BLACK CHRYSLER &amp; UNIVERSAL UNIT PKG.- 25</p>



## METRIC BODY BOLTS-OEM & UNIVERSAL

**5991**

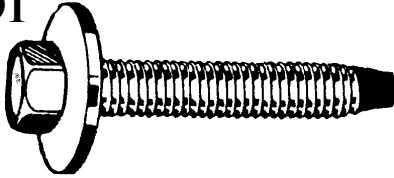

(11515923)  
 8-1.25 X 50 MM BODY BOLT  
 INDENTED HEX HD; (24 MM LOOSE  
 WASHER; 13 MM HEX) -DOG POINT  
 GM & UNIVERSAL  
 ZINC/ORGANIC PLATED

UNIT PKG.- 25

**5977**

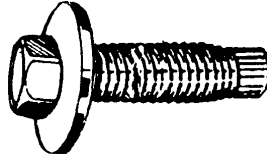

(20729795)  
 10-1.5 X 29 MM BODY BOLT  
 INDENTED HEX HD 28 MM  
 WASHER 15 MM HEX  
 GM & UNIVERSAL  
 BLACK

UNIT PKG.- 25

**3121**

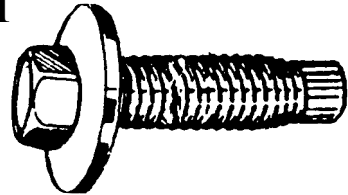

(GM11900338)  
 10-1.50 X 35 MM  
 HEX HEAD BODY BOLT  
 28 MM LOOSE WASHER  
 16 MM HEX; DOG-POINT  
 ZINC ORGANIC  
 UNIT PKG.-10

**3321**

(11517372)

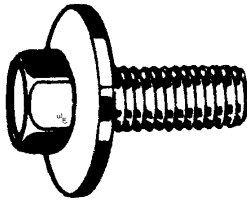

10-1.5 X 25 MM  
 HEX HEAD BODY BOLT (15 MM HEX)  
 WITH 28 MM LOOSE WASHER-ZINC PHOSPHATE-GM &  
 UNIVERSAL  
 UNIT PKG.-25

**3320**

(W505435)

8-1.25 X 30 MM  
 HEX HEAD BODY BOLT  
 (13 MM HEX) WITH 24 MM  
 LOOSE WASHER  
 PILOT POINT  
 FORD & UNIVERSAL  
 ZINC PHOSPHATE  
 UNIT PKG.-25

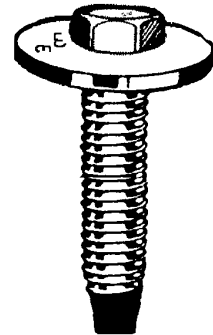

## HEX HEAD BODY BOLTS- USS

**940**

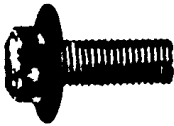

1/4''-20 X 5/8'' USS  
 5/8'' WASHER O.D.  
 HEX WASHER HEAD  
 "GRIP LOCK" BOLT BLACK  
 GENERAL PURPOSE  
 UNIT PKG.-100

**942**

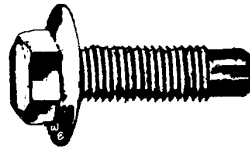

5/16''-18 X 1'' USS HEX WASHER  
 HEAD "GRIP LOCK" BOLT  
 (51/64'' WASHER O.D)  
 DOG POINT-BLACK  
 UNIT PKG.-25

**943**

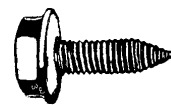

(3960314)  
 5/16''-18 X 13/16'' USS  
 HEX WASHER HEAD BOLT  
 (21/32'' WASHER O.D.)  
 CA POINT  
 BLACK  
 UNIT PKG.-50

**944**

(3986997)  
 (14011722)

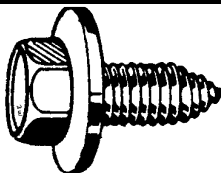

3/8-16 X 1'' USS HEX HEAD BOLT  
 WITH 1'' LOOSE WASHER; CA  
 PT HOOD HINGE TO FENDER  
 GM- '71-'76  
 UNIT PKG.-25

**945**

(407217),  
 (1564180)

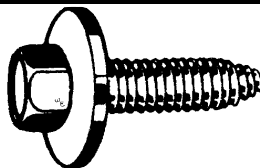





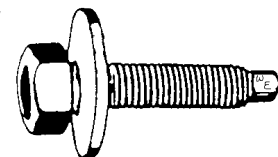

3/8''-16 X 1-1/2'' USS HEX HEAD BOLT  
 CA POINT WITH 1-1/8'' LOOSE  
 WASHER; 9/16'' HEX  
 HOOD HINGE TO FENDER-GM- '71-'76  
 UNIT PKG.-25

**2747**

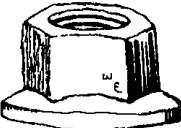

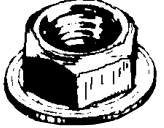
(06025334)  
 1/4''-20 X 1-1/4'' BODY BOLT  
 (7/16'' HEX; 3/4'' LOOSE  
 WASHER)-DOG POINT  
 UNIT PKG.-50

## FLANGE NUTS "GRIP LOCK" -BLACK FINISH

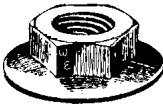
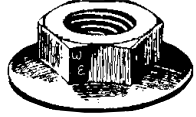
<p><b>5909</b> (11501850)</p>  <p style="text-align: center;"><b>10-1.5 MM HEX FLANGE NUT</b> (15 MM HEX); (21 MM FLANGE) GM &amp; UNIVERSAL UNIT PKG.-25</p>	<p><b>5941</b></p>  <p style="text-align: center;"><b>6-1.0 MM HEX FLANGE NUT</b> (10 MM HEX) (13.5 MM FLANGE ) UNIT PKG.-25</p>	<p><b>5931</b> (6500165) (11501889) (11514596)</p>  <p style="text-align: center;"><b>8-1.25 MM HEX FLANGE NUT</b> (13 MM HEX); (17 MM FLANGE) CHRYSLER, GM AND UNIVERSAL UNIT PKG.-25</p>
<p><b>5938</b> (11502702)</p>  <p style="text-align: center;"><b>5-0.8 MM HEX FLANGE NUT</b> (8 MM HEX); (11.5 MM FLANGE) GM &amp; UNIVERAL UNIT PKG.-50</p>	<p><b>797</b></p>  <p style="text-align: center;"><b>10-24 HEX FLANGE NUT</b> (31/64" FLANGE) UNIT PKG.-100</p>	<p><b>798</b></p>  <p style="text-align: center;"><b>1/4"-20 HEX FLANGE NUT</b> (37/64" FLANGE) UNIT PKG.-100</p>
<p><b>799</b></p>  <p style="text-align: center;"><b>5/16"-18 HEX FLANGE NUT</b> (21/32" FLANGE) UNIT PKG.-100</p>	<p><b>800</b></p>  <p style="text-align: center;"><b>3/8"-16 HEX FLANGE NUT</b> (3/4" FLANGE) UNIT PKG.-50</p>	

## FREE SPINNING WASHER NUTS

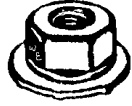
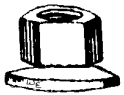
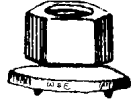
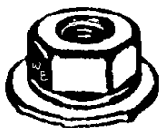
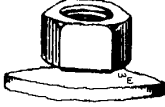
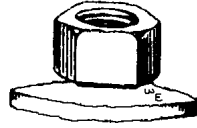
<p><b>5975</b></p>  <p style="text-align: center;">(N621901-S36) <b>4-0.7 MM NUT WITH</b> <b>FREE SPINNING 16</b> <b>MM WASHER; 9 MM</b> <b>HEX-ZINC/YELLOW</b> <b>PLATING FORD &amp;</b> <b>UNIVERSAL</b> UNIT PKG.-25</p>	<p><b>5965</b></p>  <p style="text-align: center;">(N621903), (4200408) (11501099) <b>5-0.8 MM NUT WITH</b> <b>FREE SPINNING 15 MM</b> <b>WASHER; 10 MM HEX</b> <b>PHOS &amp; OIL</b> GM, FORD &amp; UNIV. UNIT PKG.-25</p>	<p><b>5922</b></p>  <p style="text-align: center;">(VW-N90100001) (11503752), (11505329) <b>6-1.0 MM NUT WITH FREE</b> <b>SPINNING 16 MM WSHR</b> <b>10 MM HEX</b> <b>PHOS &amp; OIL</b> VW, GM-'79 &amp; UP UNIT PKG.-25</p>	<p><b>5948</b></p>  <p style="text-align: center;">(11503754), (11503756) (11505214), (6100049) <b>6-1.0 MM NUT WITH FREE</b> <b>SPINNING 19 MM WSHR</b> <b>10 MM HEX</b> <b>PHOS &amp; OIL</b> GM &amp; CHRYSLER UNIT PKG.-25</p>
<p><b>5983</b> (N621907-S55)</p>  <p style="text-align: center;"><b>6-1.0 MM NUT WITH FREE SPIN.</b> <b>24 MM WASHER; 11 MM HEX</b> <b>ZINC &amp; BLACK</b> <b>FORD PRODUCTS</b> UNIT PKG.-25</p>	<p><b>5908</b></p>  <p style="text-align: center;">(11500401), (11503695), (N621940) <b>8-1.25 MM NUT WITH FREE SPINNING 24 MM WASHER;</b> <b>13 MM HEX- PHOS &amp; OIL</b> GM- '77 &amp; UP; - FORD UNIT PKG.-25</p>		

## BUMPER BOLTS LOCKING NUTS, RETAINERS

728 UNIT PKG.-25  
729 UNIT PKG.-100

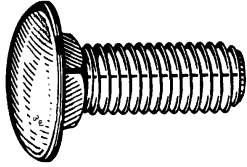

**BUMPER BOLTS**  
3/8"-16 X 1"; ROUND HEAD  
STAINLESS STEEL CAPPED  
RAMBLER, CORVAIR, VALIANT

730 UNIT PKG.-20  
731 UNIT PKG.-100

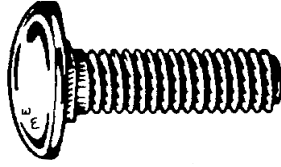

**BUMPER BOLTS**  
7/16"-14 X 1" PAN HEAD  
STAINLESS STEEL CAPPED  
FALCON AND COMET

732 UNIT PKG.-20  
733 UNIT PKG.-100

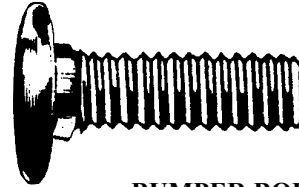

**BUMPER BOLTS**  
7/6"-14 X 1-3/8" PAN HEAD  
STAINLESS STEEL CAPPED  
FALCON AND COMET

740 UNIT PKG.-25  
741 UNIT PKG.-100

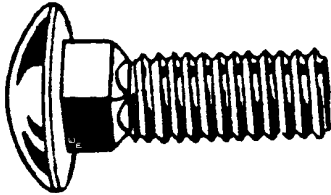

**BUMPER BOLTS**  
1/2-13 X 1-1/2"; ROUND HEAD  
STAINLESS STEEL CAPPED

5945  
(14003784)  
(N800744-S)

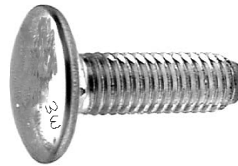

**BUMPER BOLTS**  
8-1.25 X 25 MM  
STAINLESS STEEL CAPPED  
GM, FORD & UNIVERSAL

UNIT PKG.-15

2231

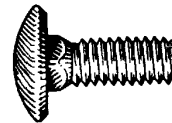

**BUMPER BOLTS**  
1/4"-20 X 3/4"  
STAINLESS STEEL CAPPED  
USE FOR FOREIGN AND  
U.S. COMPACT CARS

UNIT PKG.-25

### REVERSIBLE HEX LOCKING NUTS- PLATED (ESPECIALLY ADAPTED FOR BUMPER BOLTS)

<u>PART NO.</u>	<u>SIZE</u>	<u>UNIT PKG.</u>	<u>PART NO.</u>	<u>SIZE</u>	<u>UNIT PKG.</u>
760	5/16-18	25	764	7/16"-14	25
761	5/16-18	100	765	7/16"-14	100
762	3/8-16	25	766	1/2"-13	25
763	3/8-16	100	767	1/2"-13	100

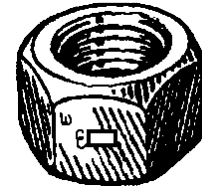

### PUSH NUT BOLT RETAINERS

<u>PART NO.</u>	<u>OE #</u>	<u>BOLT SIZE</u>	<u>O.D.</u>	<u>UPKG.</u>
1050	6026648	3/8"	25/32"	100
1051	6026647	7/16"	27/32"	100
1052		1/2"	15/16"	100
5961	6501178, 6501792, N801192S36	6 MM	17 MM	100
5916		6.3 MM	13 MM	100
5917	11502504, 11502853	8 MM	16 MM	100
5925	10009923	8 MM	24 MM	100
5918		10 MM	20 MM	100
5919		12 MM	22 MM	100
5982	11504119	14 MM	25 MM	50



### HEX MACHINE SCREW NUTS-PLATED

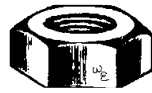

<u>PART #</u>	<u>SIZE</u>	<u>UNIT PKG.</u>
775	6-32	100
776	8-32	100
777	10-24	100
778	10-32	100
779	12-24	100
780	1/4-20	100

### "E" CLIPS EXTERNAL RETAINING RINGS



<u>PART #</u>	<u>SHAFT . DIAM</u>	<u>OUTSIDE DIAMETER</u>
2645	3/16"	.335
2646	1/4"	.527
2647	5/16"	.500
2648	3/8"	.660

EACH UNIT PKG.-100

3067

STUD CAP-WASHER STYLE  
FOR 1/4" STUD, CAP DIAM.-9/32"  
CAP HEIGHT-13/64", WASHER DIAM.-9/16"  
BLACK PHOSPHATE  
UNIT PKG.-100

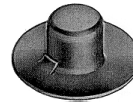

### FLAT NUTS (FOR USE WITH SHEET METAL SCREWS)



<u>PART NO</u>	<u>SCREW SIZE</u>
2572	#6
2573	#8
2574	#10

EACH UNIT PKG.-100

### WASHER LOCKNUTS-PLATED



<u>PART NO.</u>	<u>SIZE</u>	<u>HEX HEAD</u>	<u>O.D.</u>
786	8-32	11/32"	5/8"
787	10-24	3/8"	1/2"
788	10-24	3/8"	3/4"
789	10-32	3/8"	1/2"
793	1/4-20	7/16"	13/16"

EACH UNIT PKG.-100

929

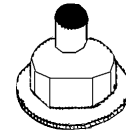

(6026686)  
HEX WASHER HEAD  
SELF THREADING NUT  
1/4" STUD SIZE (3/4" FLANGE)  
CHRYSLER & UNIVERSAL  
UNIT PKG.-25

### UNTHREADED STUD RETAINERS ZINC PLATED



<u>PART NO.</u>	<u>SIZE</u>	<u>(MM)</u>	<u>O.D.</u>	<u>(MM)</u>
2464	3/32"	(2.4)	3/16"	(4.8)
2465	1/8"	(3.2)	3/8"	(9.5)
2466	5/32"	(4.0)	7/16"	(11.1)
2467	3/16"	(4.8)	7/16"	(11.1)
2791	15/64"	(6.0)	17/32"	(13.5)
2468	1/4"	(6.4)	17/32"	(13.5)
2469	3/8"	(9.5)	3/4"	(19.0)

EACH UNIT PKG.-100



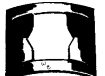









### PUSH-ON CLIPS (FOR NAME PLATES, DUMMY BUMPER BOLTS, ETC.)



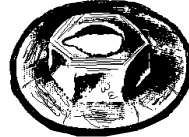

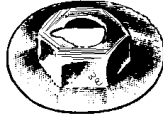

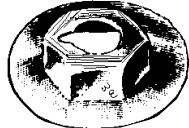



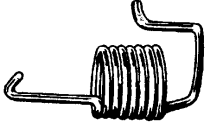
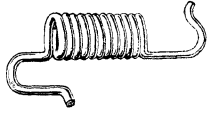

<u>PART NO</u>	<u>STUD SIZE</u>
885	1/16"
886	3/32"
887	1/8"
888	5/32"
889	3/16"
890	1/4"

EACH UNIT PKG.-100

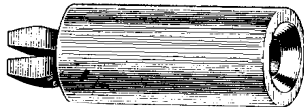
## THREAD CUTTING NUTS/WASHER TYPE LOCK NUTS

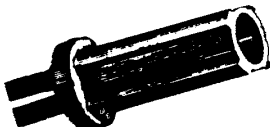
<p><b>920</b></p>  <p style="text-align: center;"> <b>THREAD CUTTING NUT</b>  <b>1/8" STUD</b>  <b>(17/32" FLANGE)</b>  <b>UNIT PKG.-100</b> </p>	<p><b>921</b></p>  <p style="text-align: center;"> <b>THREAD CUTTING NUT</b>  <b>3/16" STUD (9/16" FLANGE)</b>  <b>UNIT PKG.-100</b> </p>	
<p><b>922</b></p>  <p style="text-align: center;"> <b>THREAD CUTTING NUT</b>  <b>1/4" STUD (19/32" FLANGE)</b>    <b>UNIT PKG.-100</b> </p>	<p><b>923</b></p>  <p style="text-align: center;"> <b>THREAD CUTTING NUT</b>  <b>5/32" STUD</b>  <b>(9/16" FLANGE)</b>    <b>UNIT PKG.-100</b> </p>	
<p><b>2562</b> (REPLACES OE 11501836)</p>  <p style="text-align: center;"> <b>THREAD CUTTING NUT</b>  <b>1/4" (6.3 MM) STUD; 7/16" HEX</b>  <b>11/16" (17.5 MM) WASHER O.D.</b>  <b>(WIDER WASHER THAN W&amp;E #922)</b>  <b>ZINC PLATED</b>  <b>UNIT PKG.-100</b> </p>	<p><b>2980</b> (20625733)</p>  <p style="text-align: center;"> <b>WASHER LOCKNUT</b>  <b>M5-1.6 THREAD</b>  <b>DACROMET FINISH-GM</b>  <b>10 MM HEX</b>  <b>14 MM WASHER O.D.</b>  <b>UNIT PKG.-50</b> </p>	<p><b>2790</b></p>  <p style="text-align: center;"> <b>6 MM WASHER TYPE</b>  <b>LOCK NUT WITH SEALER</b>  <b>18 MM FLANGE DIAMETER</b>  <b>BLACK</b>  <b>UNIT PKG.-50</b> </p>
<p><b>5913</b></p>  <p style="text-align: center;"> <b>(11502540)</b>  <b>THREAD CUTTING NUT</b>  <b>4 MM STUD</b>  <b>15 MM FLANGE DIAMETER</b>  <b>UNIT PKG.-100</b> </p>	<p><b>5914</b> (11501835,10062,11501932; SUB FOR 11508900)</p>  <p style="text-align: center;"> <b>THREAD CUTTING NUT</b>  <b>5 MM STUD</b>  <b>15 MM FLANGE DIAMETER</b>  <b>UNIT PKG.-100</b> </p>	<p><b>3184</b> (GM-15709267)</p>  <p style="text-align: center;"> <b>M5-.8 WASHER TYPE LOCK NUT</b>  <b>10 MM HEX</b>  <b>18 MM WASHER DIAMETER</b>  <b>BLACK</b>  <b>UNIT PKG.-50</b> </p>
<p><b>5946</b></p>  <p style="text-align: center;"> <b>(11502507)</b>  <b>THREAD CUTTING NUT</b>  <b>8 MM STUD</b>  <b>(20 MM FLANGE DIAMETER)</b>  <b>BLACK</b>  <b>UNIT PKG.-100</b> </p>	<p><b>5928</b></p>  <p style="text-align: center;"> <b>(11503691)</b>  <b>6 MM WASHER TYPE</b>  <b>LOCK NUT; (18 MM FLANGE)</b>  <b>GM CARS</b>  <b>UNIT PKG.-50</b> </p>	<p><b>5990</b></p>  <p style="text-align: center;"> <b>THREAD CUTTING NUT</b>  <b>FOR 3.2 MM (1/8") STUD</b>  <b>8 MM HEX</b>  <b>14 MM FLANGE DIAMETER</b>  <b>UNIT PKG.-100</b> </p>

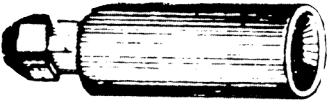
## HEADLAMP SPRINGS, RETAINERS

<p><b>1024</b></p>  <p>(555388, 554459)  <b>HEADLAMP ADJUSTING SPRING</b>          OLDSMOBILE: CUTLASS, DELTA 88          NINETY-EIGHT, TORONADO-'75-'77          UNIT PKG.- 10</p>	<p><b>2178</b></p>  <p>(D4ZZ-13031A)  <b>HEADLAMP ADJUSTING SPRING</b>          FORD: MUSTANG, GRANDA, TORINO-'74-'75          UNIT PKG.-10</p>	
<p><b>840</b></p>  <p>(E25B-13B160AA)  <b>HEADLAMP ADJUSTING RING BEARING</b>          FORD-'74-'76          UNIT PKG.-25</p>	<p><b>2888</b> (15022087)</p>  <p><b>HEADLIGHT RETAINER</b>          1/4" ALL STEEL SHOULDER RIVET-ZINC          (19/32" FLANGE DIAM., 25/64" SHOULDER DIAM.)          (.047-.079: GRIP RANGE)          GM BLAZER- '98 &amp; UP          UNIT PKG.- 10</p>	
<p><b>2179</b> (D5UZ-13031-A)</p>  <p><b>HEADLAMP ADJUSTING SPRING</b>          FORD: PINTO &amp; MAVERICK-'75          UNIT PKG.-10</p>	<p><b>829</b> (3863669)</p>  <p><b>HEADLAMP TO GRILLE RETAINING NUT</b>          CHEVROLET          UNIT PKG.-50</p>	
<p><b>830</b></p>  <p>(2524526)  <b>HEADLAMP DOOR RETAINING NUT</b>          GM AND CHRYSLER          UNIT PKG.-50</p>	<p><b>836</b></p>  <p>(1385235)          REPLACES-(1383497)          REPLACES-(1379013)  <b>HEADLAMP DOOR RETAINER</b>          GM PRODUCTS-'67 TO '72          UNIT PKG.-25</p>	<p><b>842</b> (411847)</p>  <p><b>HEADLAMP DOOR FASTENER &amp; COVER, SPACER- TOGGLE TYPE</b>          .312 SQUARE HOLE, 1/2" COLLAR          GM &amp; UNIVERSAL          UNIT PKG.-25</p>
<p><b>2143</b></p>  <p>(152867)  <b>HEADLAMP SPACER</b>          NYLON-1" LONG          CHRYSLER PRODUCTS-'78 &amp; UP          UNIT PKG.-25</p>	<p><b>2383</b></p>  <p>(D5UB13B-160-AA)  <b>HEADLAMP ADJUSTING RING BEARING</b>          FORD-'75 &amp; UP          UNIT PKG.-50</p>	<p style="text-align: center;">CONTACT US WITH ANY          NEW ITEMS, ASSORTMENTS,          OR SUGGESTIONS</p> <p style="text-align: center;">PLEASE ALSO VISIT OUR          WEBSITE AT:</p> <p style="text-align: center;"><b>WWW.WESALES.COM</b></p>

## HEADLAMP PARTS-NUTS, SCREWS AND RETAINERS

**1011**

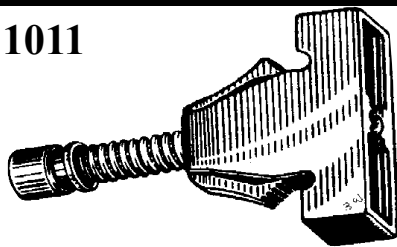

(556359, 557057, 556196)  
**HEADLAMP ADJUSTING  
 NUT AND SCREW**  
 #12-28 X 1-3/4"  
 GM- '77 & UP  
 UNIT PKG.-10

**1012**

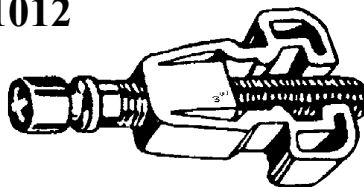

(1600375, 1606642)  
**HEADLAMP ADJUSTING  
 NUT AND SCREW**  
 1/4"-28 X 2"  
 GM-CADILLAC-'72 & UP  
 UNIT PKG.-10

**1013**

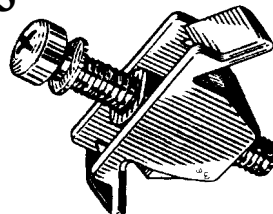

**HEADLAMP ADJUSTING  
 NUT AND SCREW**  
 CHRYSLER- '72 & UP  
 UNIT PKG.-10

**2116**

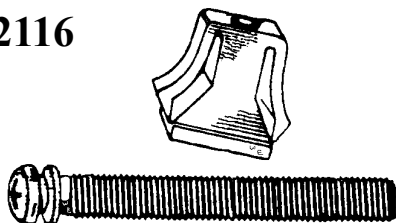

(365266, 365270)  
**HEADLAMP ADJUSTING  
 NUT AND SCREW**  
 1/4"-28 X 2"  
 (USE ON FIBERGLASS BUCKETS)  
 GM- '75 & UP  
 UNIT PKG.-10

**2118**

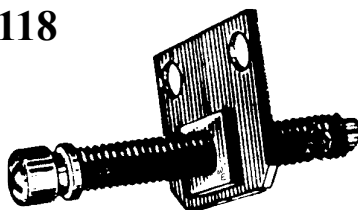

(D3HB-13A093-AB)  
**HEADLAMP ADJUSTING  
 NUT AND SCREW**  
 1/4"-28 X 1-3/4"  
 FORD- '70 & UP  
 UNIT PKG.-10

**2119**

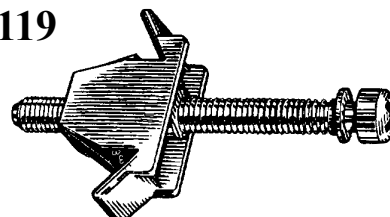

(5201359, 5201269, 3868985)  
**HEADLAMP ADJUSTING  
 NUT AND SCREW**  
 #12-28 X 1-3/4"  
 CHRYSLER- '77 & UP  
 UNIT PKG.-10

**2144**

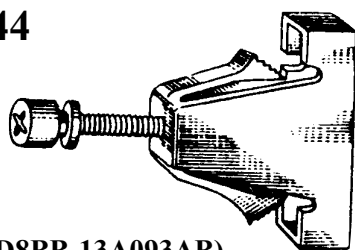

(D8BB-13A093AB)  
**HEADLAMP ADJUSTING  
 NUT AND SCREW**  
 FORD- '78 & UP  
 UNIT PKG.-10

**1025**

(D3AB-138093-AC)

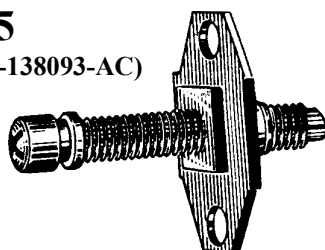

**HEADLAMP ADJUSTING  
 NUT AND SCREW**  
 FORD- '73 & UP  
 UNIT PKG.-10

**1010**



(3691599)  
**HEADLAMP ADJUSTING  
 NUT AND SCREW**  
 (FIBERGLASS HDLMP BUCKETS)  
 CHRYSLER- '74 & UP  
 UNIT PKG.-10

**1034**

(1493541)  
**HEADLAMP ADJUSTING  
 NUT AND SCREW**  
 GM- '69 & UP  
 UNIT PKG.-10

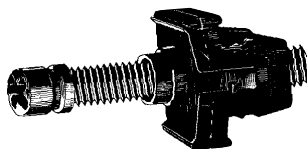

PLEASE CONTACT US  
 WITH ANY QUESTIONS

**WWW.WESALES.COM**

## HEADLAMP PARTS-NUTS, SCREWS AND RETAINERS

**2456**

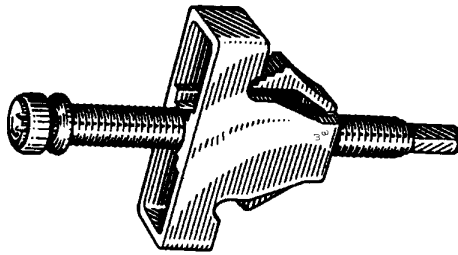

(4388249)  
**HEADLAMP ADJUSTING  
 NUT AND SCREW- TORX DRIVE 12-28 X 2-3/8"**  
 CHRYSLER-VANS, MINIVANS '88 & UP  
 UNIT PKG.-10

**2535**

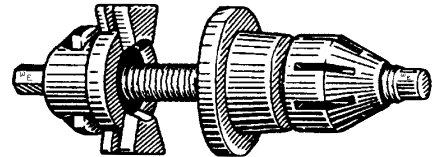

(F24B-13A093-BA)  
 (E9DB-13A093-AA)  
**REPLACES (E9DZ-13032-A)  
 HEADLAMP ADJUSTING  
 NUT AND SCREW**  
 TAURUS & SABLE- '89 & UP  
 UNIT PKG.-5

**2235**

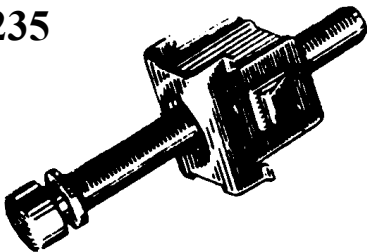

(E1EB 13A093AA)  
 (E1TB 13A093AA)  
**HEADLAMP ADJUSTING  
 NUT AND SCREW**  
 FORD BRONCO, ECONOLINE,  
 LT TRUCKS, ESCORT, RANGER,  
 & LYNX-'77 & UP  
 UNIT PKG.-10

**2268**

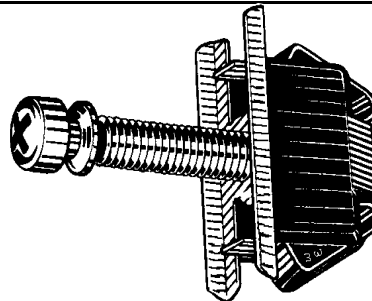

(E3DB-13A093AF), (E3DZ-13032A, 13032C)  
**HEADLAMP ADJUSTING  
 NUT AND SCREW**  
 T-BIRD, COUGAR, FORD LTD,  
 MERCURY MARQUIS, TEMPO &  
 TOPAZ-'83 & UP  
 UNIT PKG.-5

**835**

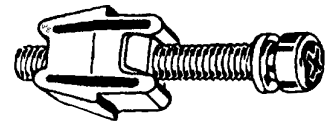

**HEADLAMP ADJUSTING  
 NUT AND SCREW**  
 CHRYSLER PRODUCTS  
 UNIT PKG.-10

**2124**  
 (365270)

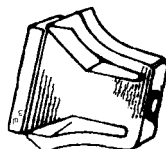

**HEADLAMP  
 ADJUSTING NUT**  
 USE ON FIBERGLASS BUCKETS  
 NYLON-GREEN  
 GM- '75 & UP  
 UNIT PKG.-50

**839**

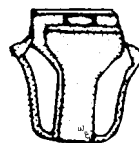

(354076, 343541, 343542)  
**HEADLAMP ADJUSTING NUT**  
 USE WITH W&E #1040  
 GM- '75 & UP  
 UNIT PKG.-25

**837**

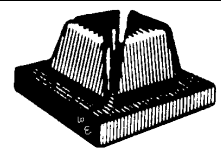

(3921446)  
**HEADLAMP ADJUSTING NUT**  
 THREAD SIZE 1/4-28  
 GM  
 UNIT PKG.-50

**1040**



(343543, 354076)  
**HEADLAMP ADJUSTING SCREW**  
 1/4-28 x 2" (GM & UNIVERSAL)  
 USE WITH W&E #S 837, 839 & 2124  
 UNIT PKG.-25

**1041**



**HEADLAMP ADJUSTING SCREW**  
 #12-28 x 1-3/4"  
 (GM, CHRYSLER & UNIVERSAL)  
 UNIT PKG.-25



## HEADLAMP PARTS-NUTS, SCREWS AND RETAINERS

**2534**

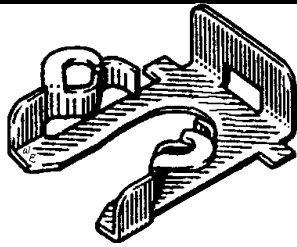

(E9DZ-13N129-A  
F2AB-13N020-AA  
(REPLACES-E9DB-13N020-AA)  
HEADLAMP RETAINER  
TAURUS, SABLE, T-BIRD, TEMPO,  
TOPAZ, ECONOVAN  
UNIT PKG.-15

**2580**



(PICTURE NOT ACTUAL SIZE)  
(16508139, 16504937, 16505374)  
HEADLAMP ADJUSTING  
GEAR ASSEMBLY  
GM-'86 & UP  
UNIT PKG.-1

**3237**

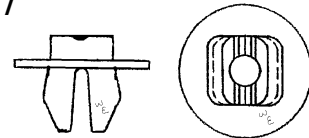

(90189-05142)  
PLASTIC SCREW GROMMET  
HEADLAMP ASSEMBLY  
GRILLE RETAINER  
FOR 9 MM HOLE  
17 MM FLANGE DIAMETER  
TAKES 4.2 MM (#8) SCREW  
TOYOTA LEXUS-2001 & UP  
UNIT PKG.-25

**2700**

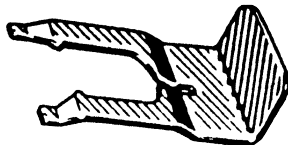

(F37-13N129A)  
HEADLAMP RETAINER  
ADJUSTING BAR TO HEADER PANEL  
FORD RANGER-'93 & UP  
UNIT PKG.-25

**2211**



DATSUN-(26022-H1010)  
TOYOTA-(81131-12150)  
(E3DZ-13032A, 13032C)  
HEADLAMP ADJUSTING SCREW  
5 MM X 40 MM  
UNIT PKG.-25

**2212**



(26023-H1000)  
HEADLAMP ADJUSTING  
NUT-DATSUN  
UNIT PKG.-25

**2610**

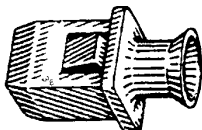

(8131-89103)  
HEADLAMP ADJUSTING NUT  
USES 5 MM SCREW  
TOYOTA TRUCKS- '84 & UP  
UNIT PKG.-10

**2611**

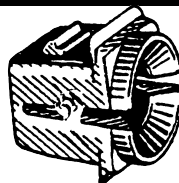

(81132-32121, 81127-01010,  
95900-08025)  
HEADLAMP ADJUSTING NUT  
FOR 13 MM X 16 MM HOLE  
TOYOTA- '88 & UP  
UNIT PKG.-10

**2248**

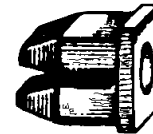

(90189-05013), (MS-480002)  
HEADLAMP ADJUSTING NUT  
12 MM SQUARE HD; #8-10 SCREW  
FOR 9 MM HOLE  
TOYOTA & MITSUBISHI  
UNIT PKG.-25

**832**



(3880632)  
HEADLAMP DOOR  
UPPER RETAINER  
GM  
UNIT PKG.-50

**844**











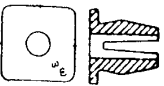

(3986978)  
HEADLAMP BEZEL NUT  
CHEVROLET- '71-'77  
UNIT PKG.-25

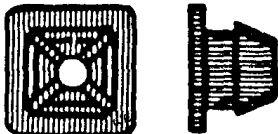
**2338**

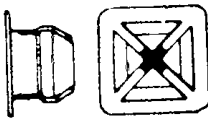

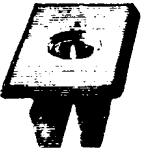
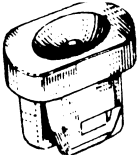
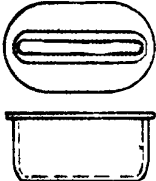
(VW-179-813-883)  
(REP. GM-1355003), (1370853)  
HEADLAMP BEZEL NUT  
9.5 MM SQUARE HD; #6 SCREW  
FOR 6.5 MM HOLE  
VW, GM, RENAULT  
& UNIVERSAL  
UNIT PKG.-50

## NUTS, GROMMETS, RETAINERS

<p><b>815</b> </p> <p>(6010082)  <b>HEADLAMP DOOR NUT</b>            (3/8"SQ.HD; #8-10SCR, .266" HOLE)            FORD, DODGE, PLYMOUTH            DODGE TRUCKS</p> <p style="text-align: center;">UNIT PKG.-100</p>	<p><b>817</b> </p> <p>(3919773, 3893980)  <b>PLASTIC SCREW NUT</b>  <b>GRILLE ATTACHING</b>            .300" HOLE</p> <p style="text-align: center;">UNIT PKG.-100</p>	<p><b>818</b> </p> <p>(3907444), (379046-S)  <b>LICENSE PLATE NUT-UNIVERSAL</b>            (USE #14 SCREWS)            (W&amp;E 537, 2203, 2326, 2547)</p> <p style="text-align: center;">UNIT PKG.-50</p>
<p><b>819</b> </p> <p>(379830-S)  <b>HEADLAMP DOOR NUT</b>  <b>SIDE MIRROR TO DOOR</b>  <b>GRILLE NUT (1/4" HOLE)</b>            (USE #8-10 SCREWS)</p> <p style="text-align: center;">UNIT PKG.-50</p>	<p><b>822</b> </p> <p><b>GRILLE SCREW NUT</b>            (.325" HOLE)            (USE #8-10 SCREWS)            CHEVY, BUICK &amp; UNIVERSAL</p> <p style="text-align: center;">UNIT PKG.-100</p>	<p><b>825</b> </p> <p>(1355603), (3783004), (3783006)  <b>HEADLAMP DOOR NUT</b>  <b>LICENSE PLATE NUT</b>            (USE #10 SCREWS)            GM, RAMBLER            UNIT PKG.-50</p>
<p><b>826</b> </p> <p>(1196781), (4755299)  <b>GRILLE TO RADIATOR, LIC.PLATE,</b>  <b>HDLMP ADJ. NUT</b>            5/8" SQUARE HD; #12-14 SCREW            11/32" OVERALL HEIGHT            FOR 3/8" HOLE            GM, FORD &amp; UNIVERSAL            UNIT PKG.-50</p>	<p><b>2101</b> </p> <p>(6030519)  <b>GRILLE NUT</b>  <b>CHRYSLER &amp; UNIVERSAL</b></p> <p style="text-align: center;">UNIT PKG.-50</p>	<p><b>2173</b> </p> <p>(1377030)  <b>RETAINER-BUMPER TO VALANCE</b>  <b>BAR PANEL RETAINER-PONTIAC</b>  <b>HEADLAMP SCREW -CHEVY</b>            UNIVERSAL            UNIT PKG.-50</p>
<p><b>2208</b> </p> <p>(14013246)  <b>PLASTIC NUT</b>  <b>HEADLAMP DOOR HEADER</b>  <b>PANEL &amp; SIDE LAMP</b></p> <p style="text-align: center;">GM-'80 &amp; UP            UNIT PKG.-50</p>	<p><b>2210</b> </p> <p>(FORD-61A-1808-0019)            (6031138), (6031234)  <b>PLASTIC NUT</b>  <b>HEADLAMP &amp; GRILLE</b>  <b>CHRYSLER-'77 &amp; UP, FORD</b></p> <p style="text-align: center;">UNIT PKG.-50</p>	<p><b>2213</b> </p> <p>(N800503S)  <b>PLASTIC CLIP NUT</b>  <b>FRONT FENDER &amp; DASH</b></p> <p style="text-align: center;">FORD-'79 &amp; UP            UNIT PKG.-50</p>

## NUTS, GROMMETS, RETAINERS

**2214**



(386122S)  
**NYLON NUT**  
 FOR 15/64" HOLE  
 3/8" HEAD O.D.  
 TAKES #8 SCREW  
 (LARGER THAN W&E #819)  
 FORD & UNIVERSAL  
 UNIT PKG.-50

**2236**



(901894042, 95900-04036), (96706B0700)  
 (75522-611-0000), (9991-00412)  
 (MS-480001)  
**PLASTIC NUT- SIDE MARKER LAMP**  
 9.5 MM SQUARE HEAD; #6 SCREW  
 8 MM OVERALL HEIGHT  
 6.4 MM HOLE  
 TOYOTA, NISSAN, HONDA, MAZDA,  
 MITSUBISHI AND UNIVERSAL  
 UNIT PKG.-100

**2244**



(3919773, 347347)  
**PLASTIC SCREW NUT**  
**HEADLAMP BEZEL-GM**  
 UNIT PKG.-50

**2247**



(22514578)  
**PARKING LAMP ASSEMBLY**  
**NUT-PLASTIC**  
 (FOR THIN PANELS)  
 GM & UNIVERSAL  
 UNIT PKG.-25

**2277**

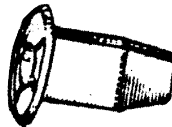

(96706-U0100), (90189-06001)  
 (01281-00023), (MB-098145)  
**PLASTIC SCREW GROMMET**  
 FOR 9 MM SQUARE HOLE  
 18 MM HEAD; #10 SCREW  
 19 MM OVERALL HEIGHT  
 TOYOTA, NISSAN, MITSUBISHI  
 UNIT PKG.-25

**2305**

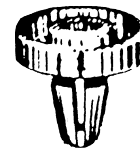

(5118-1852-299)  
**PLASTIC NUT TYPE**  
**FASTENER-BMW**  
 UNIT PKG.-25

**2339**

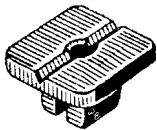

(6825-H 5000)  
 (90662-671-0030)  
 (9991-00-503)  
**PLASTIC NUT**  
 GENERAL USAGE  
 NISSAN, HONDA, MAZDA  
 UNIT PKG.-25

**2374**

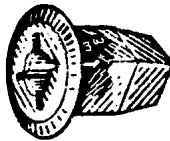

(90661-SC7-0030; 90189-06042; 01651-00481; 74798-S9000; H001-50-841)  
**PLASTIC SCREW GROMMET**  
 FOR 9 MM SQUARE HOLE  
 #10 SCREW; 16 MM HEAD O.D.  
 19 MM OVERALL HEIGHT  
 HONDA, TOYOTA, NISSAN, MAZDA  
 UNIT PKG.-25

**2381**



(90189-04008)  
 (MB029-111), (94841130)  
**GRILLE NUT/ GROMMET**  
 TOYOTA, MITSUBISHI  
 GM-NOVA '85  
 UNIT PKG.-20

**2406**



(14032291)  
**GRILLE NUT-GROMMET**  
 7.5 MM HOLE  
 GM  
 UNIT PKG.-50

**2445**

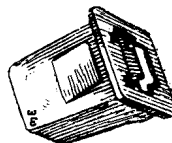





(D9BB-5402316-AA)  
**COWL PANEL RETAINER**  
 FORD- '79 & UP  
 UNIT PKG.-25

**2473**

(90189-04013) 

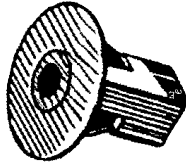
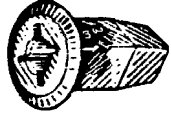
**SCREW GROMMET**  
 7.8 MM HOLE  
 14 MM HEAD DIAMETER  
 16 MM OVERALL LENGTH  
 TOYOTA  
 UNIT PKG.-25

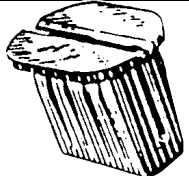
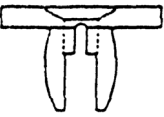
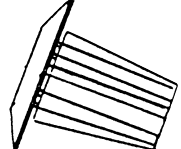
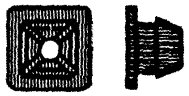
## NUTS, GROMMETS, RETAINERS

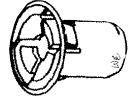
<p><b>2479</b></p>  <p>(171-853-615A)  <b>NAME PLATE GROMMET</b>            7 MM HOLE            10 MM O/A LENGTH            VW-'80 &amp; UP    <b>UNIT PKG.-25</b></p>	<p><b>2494</b>            (90189-06013)</p>  <p>(REPL.-TOYOTA-90189-06065)            (29818-474D3; 96706-W1000)  <b>PLASTIC GROMMET FENDER SHIELD</b>            6.3 MM (#14) SCREW SIZE            20 MM HEAD; 8 X 8 MM HOLE  <b>TOYOTA</b>  <b>UNIT PKG.-20</b></p>	<p><b>2502</b></p>  <p>(96706-H9400, K1300,1351)            (90686-SBO-003), (90189-04033)            (B033-68-805), (MB 106212)  <b>NYLON SCREW GROMMET</b>  <b>FOR 7 MM SQUARE HOLE</b>            13 MM HEAD O.D.            12 MM OVERALL HEIGHT            TAKES #8 SCREW  <b>MDZA,NISS,HONDA,MITS,TOYOTA</b>  <b>UNIT PKG.-25</b></p>
<p><b>2503</b></p>  <p>(9991-00-601), (91619-SA5-003)            (96706-P0105), (901-89-06010)  <b>NYLON SCREW GROMMET</b>            13 MM SQ. HD, #10 SCREW,            10 MM OVERALL HEIGHT,            FOR 9 MM HOLE  <b>MAZDA, HONDA,</b>  <b>NISSAN &amp; TOYOTA</b>  <b>UNIT PKG.-25</b></p>	<p><b>2539</b></p>  <p>(96706-H2500)  <b>SCREW GROMMET</b>            #6 SCREW            6.5 MM HOLE            11.5 MM HEAD DIAMETER            10.5 MM OVERALL LENGTH  <b>NISSAN</b>  <b>UNIT PKG.-25</b></p>	<p><b>2581</b></p>  <p>(GM-10032838, 1264963)            (CHRYSLER-6031869)            (AMC-8934-201-602)  <b>SCREW GROMMET</b>  <b>HOOD HINGE; GRILL AND</b>  <b>FLOOR TRIM CLIP</b>  <b>UNIT PKG.-25</b></p>
<p><b>2681</b></p>  <p>(W700505S300)            (REPLACES-W702438S100)  <b>SCREW GROMMET</b>  <b>GRILLE, RADIATOR SHIELD</b>            #8-10 SCREW            20 MM HD DIAMETER            FITS 8 X 10 MM HOLE  <b>FORD- CONTOUR &amp; MYSTIQUE</b>  <b>UNIT PKG.-50</b></p>	<p><b>2683</b></p>  <p>(W700158S300)  <b>SCREW GROMMET-DOOR TRIM</b>            22.5 MM HD DIAMETER            12 MM HOLE            21 MM OVERALL LENGTH  <b>FORD-CONTOUR &amp; MYSTIQUE</b>  <b>UNIT PKG.-25</b></p>	<p><b>2720</b></p>  <p>(6503108)  <b>SCREW GROMMET W/SEALER</b>  <b>LUGGAGE COMP.</b>  <b>TRUNK TRIM</b>            5/16" HOLE, #8 SCREW  <b>CHRYSLER</b>  <b>UNIT PKG.-25</b></p>
<p><b>2756</b>            (N807994-S)            (REPLACES            W704740S300)</p>  <p><b>PLASTIC GROMMET</b>  <b>GRILLE &amp; SIDE MARKER</b>  <b>FOR 10 MM HOLE</b>  <b>FORD-'94 &amp; UP</b>  <b>UNIT PKG.-25</b></p>	<p><b>2768</b>            (8545-50-786)</p>  <p><b>SCREW GROMMET</b>            7 MM HOLE; FOR #10 SCREW            13 MM HEAD DIAMETER  <b>MAZDA</b>  <b>UNIT PKG.-25</b></p>	<p><b>2850</b></p>  <p>(N807706-S)  <b>RETAINER- TAIL LAMP AND</b>  <b>FRONT FASCIA GROMMET</b>  <b>FOR 10 MM HOLE SIZE</b>  <b>FORD- '95 &amp; UP</b>  <b>UNIT PKG.- 25</b></p>

## NUTS, GROMMETS, RETAINERS

**2866**

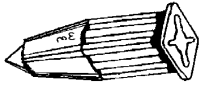

(N804765-S)  
**SCREW GROMMET**  
 WHEEL OPENING  
 FOR #8 SCREW  
 7 MM SQUARE HOLE  
 FORD PRODUCTS  
 UNIT PKG.- 50

**2947**

(W703069-S300)

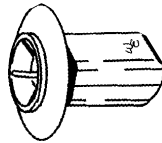

**PLASTIC GROMMET**  
 FRONT GRILLE/ FENDER  
 FOR 8 MM SQUARE HOLE  
 18 MM FLANGE DIAMETER  
 4.2 MM (#8) SCREW  
 FORD FOCUS: 2000-2001  
 UNIT PKG.-50

**2963**



(TOYOTA-90189-05012)  
 (ISUZU-8941340270)  
**SCREW GROMMET**  
 6 MM X 10 MM HOLE  
 16 MM WIDE; 12 MM LONG  
 #6 SCREW  
 TOYOTA, LEXUS, ISUZU  
 UNIT PKG.-50

**2965**

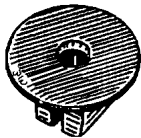

(TOYOTA 90189-06006)  
 (REPL. NISSAN 01281-00111)  
**SCREW GROMMET**  
 FOR #10 SCREW  
 HEAD DIAMETER 17 MM  
 9 MM SQUARE HOLE  
 TOYOTA & NISSAN  
 UNIT PKG.-25

**2969**



(90107-SX0-003)  
**BUMPER GROMMET**  
 FOR #10 SCREW  
 HONDA/ACURA  
 ACCORD & PRELUDE  
 1996 & UP  
 UNIT PKG.-10

**2970**

(90106-SW3-003)

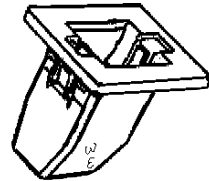

**BUMPER GROMMET**  
 HEAD- 18 X 20 MM  
 20 MM OVERALL HEIGHT  
 FOR 9 X 11 MM HOLE  
 HONDA-ACCORD, PRELUDE  
 & ODYSSEY- 1995 & UP  
 UNIT PKG.-10

**2984**



(10262143)  
 (91517-SEO-0030)  
**GRILLE PANEL GROMMET**  
 AIR INTAKE  
 20 MM HEAD  
 FOR 5 MM STUD  
 GM & HONDA-'96 & UP  
 UNIT PKG.-25

**3020**



(N806334-S)  
**SCREW GROMMET**  
 FOR #8 (M4.2) SCREW  
 FOR 6 MM SQUARE HOLE  
 10 MM SQUARE HEAD  
 11 MM OVERALL HEIGHT  
 FORD-'97 & UP  
 UNIT PKG.-50

**3021**



(N802376-S)  
**SCREW GROMMET**  
 FOR #8 (M4.2) SCREW  
 FOR 6 MM SQUARE HOLE  
 9.5 MM SQUARE HEAD  
 7.5 MM OVERALL HEIGHT  
 FORD  
 UNIT PKG.-25

**3022**



(FORD-N811169S, W705550-S300)  
 (GM-10423331)  
**RETAINER-PARK &**  
**TURN SIGNAL HOUSING**  
 13 MM HEAD DIAMETER  
 11 MM OVERALL HEIGHT  
 FOR 11 MM HOLE  
 FORD- F250,F550-'99 & UP; GM  
 UNIT PKG.-50

**3025**

(4759514AB)





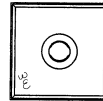
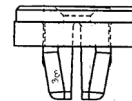

**RUBBER GROMMET**  
 FLOOR PAN PLUG & LUGGAGE  
 AREA CARPET  
 FOR 9 MM HOLE; 15 MM HD DIAM.  
 15 MM OVERALL LENGTH  
 CHRYSLER LH, LHS &  
 CONCORDE-'97 & UP  
 UNIT PKG.-50

**3026**

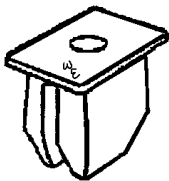
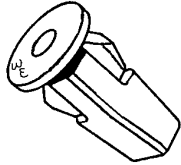
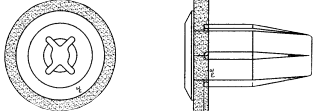

(6505703AA)  
**PLASTIC SCREW GROMMET**  
 W/SEALING WASHER; TAIL LIGHT  
 FOR #8 OR #10 SCREW  
 16 MM SQUARE HEAD  
 OVERALL HEIGHT 12 MM  
 FOR 9 MM SQUARE HOLE  
 JEEP GRAND CHEROKEE 2000 & UP  
 UNIT PKG.-15

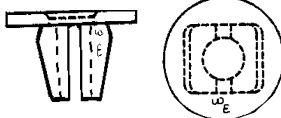
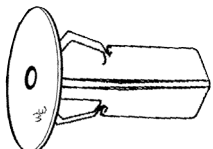
## NUTS, GROMMETS, RETAINERS

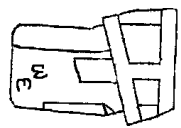
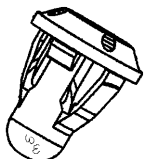
<p><b>3062</b></p>  <p>(90189-05105) SCREW GROMMET FRONT FENDER FLARE FOR M4.2 (#8) SCREW 7 X 13 MM HOLE 10 X 15 MM FLANGE TOYOTA RAV 4-'96 &amp; UP UNIT PKG.-15</p>	<p><b>3063</b></p>  <p>(90189-06028; GM 94854203) SCREW GROMMET FENDER SHIELD FOR 9 MM SQUARE HOLE FLANGE DIAMETER 16 MM FOR #12 SCREW TOYOTA-'92 &amp; UP-TACOMA, 4-RUNNER, T-100;GM-'85 &amp; UP CHEVY. &amp; PONTIAC UNIT PKG.-15</p>	<p><b>3072</b></p>  <p>(90670-SG0-003, 91626-SH3-003) PLASTIC SCREW GROMMET WITH SEALER DOOR PANEL AND SPEAKERS 7 X 7 MM HOLE 4 MM SCREW 17.5 MM OVERALL LENGTH HONDA CRV AND CIVIC '93 &amp; UP UNIT PKG.-15</p>
<p><b>3073</b></p>  <p>(90682-SB0-003) PLASTIC SCREW GROMMET GRILLE, BUMPER, FENDER 13 MM SQUARE HEAD 5 MM SCREW 8.5 MM SQUARE HOLE  HONDA-'85 &amp; UP UNIT PKG.-25</p>	<p><b>3092</b></p>  <p>(NISSAN 01281-00111) (REPLACES TOYOTA 96185-6006) BUMPER COVER SCREW GROMMET 6 MM (#10-14) SCREW FOR 10 MM SQUARE HOLE 16 MM HD DIAMETER 11 MM OVERALL HEIGHT NISSAN, TOYOTA UNIT PKG.-25</p>	<p><b>3146</b></p>  <p>(90189-06157) SCREW GROMMET #12 SCREW 8 MM SQUARE HOLE 20 MM HEAD; 22 MM LENGTH TOYOTA UNIT PKG.-15</p>
<p><b>3168</b></p>  <p>(01281-01081) PLASTIC SCREW GROMMET 6 MM (#12) SCREW 16 MM FLANGE O.D. 22 MM OVERALL LENGTH FOR 10 MM HOLE NISSAN/INFINITY-1997 &amp; UP UNIT PKG.-15</p>	<p><b>3169</b></p>  <p>(01281-01321) PLASTIC SCREW GROMMET 6 MM (#12) SCREW ANGLED HEAD 21.5 MM OVERALL LENGTH FOR 9.5 X 11.5 MM HOLE  NISSAN/INFINITY- 96 &amp; UP UNIT PKG.-15</p>	<p><b>3207</b></p>  <p>(11561655, 11609862) PLASTIC RETAINER TAIL LAMP ASSEMBLY GROMMET FOR 12 MM HOLE 15 MM HEAD DIAMETER 20 MM OVERALL HEIGHT GM-2005 &amp; UP BUICK, CHEVY, PONTIAC, SATURN UNIT PKG.-5</p>

## NUTS, GROMMETS, RETAINERS

**3211**



(01281-00831)  
**PLASTIC SCREW GROMMET**  
**FOR 8.5 MM SQUARE HOLE**  
**5 MM (#10) SCREW**  
**16 MM HEAD DIAMETER**  
**21 MM OVERALL HEIGHT**  
**.NISSAN-'89 & UP**  
**UNIT PKG.-25**

**3264**



(52535-50060)  
**BUMPER COVER SCREW**  
**GROMMET**  
**FOR 9 X 12 MM HOLE**  
**18 X 30 MM HEAD**  
**TAKES 12 MM SCREW**  
**TOYOTA CAMRY, HIGHLANDER**  
**LEXUS-2001 & UP**  
**UNIT PKG.- 5**

**3268**



(87756-35000)  
**PLASTIC GROMMET**  
**DOOR & ROCKER MOULDING**  
**13 MM SQUARE HEAD**  
**OVERALL HEIGHT 12 MM**  
**FOR 5.5 MM (#12) SCREW**  
**HYUNDAI- 1995 & UP**  
**KIA- 2006 & UP**  
**UNIT PKG.- 25**

**3271**

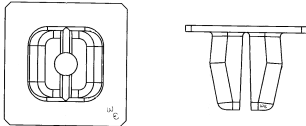

(6035401)  
**PLASTIC SCREW GROMMET**  
**BUMPER COVER AND**  
**DOOR PANELS**  
**FOR #8 SCREW**  
**9 MM SQUARE HEAD**  
**OVERALL HEIGHT 11 MM**  
**CHRYSLER- 2004 & UP**  
**UNIT PKG.- 25**

**3281**

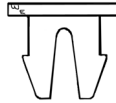

(90189-06193)  
**PLASTIC SCREW**  
**GROMMET SPLASH**  
**SHIELD RETAINER**  
**14 X 16 MM HEAD SIZE**  
**(FOR 9 X 11 MM HOLE)**  
**USE WITH 6MM (#12) SCREW**  
**TOYOTA- AVALON, CAMRY &**  
**OTHERS-2002 & UP**  
**UNIT PKG.- 25**

**3302**

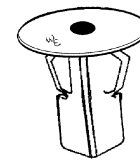

(90189-A0002), (90189-06220)  
**PLASTIC SCREW GROMMET**  
**FENDER LINER & MUD GUARD**  
**FOR 10 MM SQUARE HOLE**  
**USE WITH #10 SCREW**  
**20 MM HD O.D.; 19 MM O/A HT**  
**TOYOTA/LEXUS-2008 & UP**  
**UNIT PKG.- 25**

**3333**



(90189-04059, 90189-04229)  
**PLASTIC SCREW GROMMET**  
**ROCKER MOULDING**  
**FOR 6 X 14.5 MM HOLE**  
**FLANGE 12 X 18 MM**  
**9 MM O/A HEIGHT**  
**FOR #4 OR #6 SCREW**  
**TOYOTA & LEXUS**  
**2006 & UP**

**UNIT PKG.-25**

**3334**

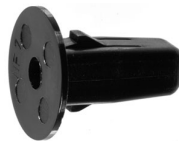

(90189-06177)  
**PLASTIC SCREW GROMMET**  
**ROCKER MOULDING**  
**FOR 9 MM SQ. HOLE**  
**20 MM HD DIAM.**  
**24 MM O/A HEIGHT**  
**FOR #12 SCREW**  
**TOYOTA-CAMRY,**  
**PRIUS, SCION, & VENZA**  
**'87 & UP**

**UNIT PKG.-15**



**3338**







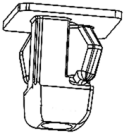

(01281-00691)  
**PLASTIC SCREW GROMMET**  
**WITH SEALER**  
**FOR 8 MM SQ. HOLE**  
**16 MM HEAD DIAM.**  
**22 MM O/A LENGTH**  
**FOR #8 SCREW**  
**NISSAN/INFINITY**  
**'04 & UP**

**UNIT PKG.-15**

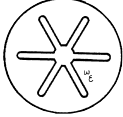
# GROMMETS, TUBULAR CLIP, RETAINERS, THREADED INSERTS

<p><b>3339</b> (90189-06211)</p>  <p><b>PLASTIC SCREW GROMMET ROCKER MLDNG &amp; PILLAR FOR 9 MM SQ. HOLE 17 MM HEAD DIAM. 10 MM STEM LENGTH FOR #12 SCREW TOYOTA/LEXUS-'07 &amp; UP UNIT PKG.-25</b></p>	<p><b>3354</b> (90682-SDA-A01)</p>  <p><b>PLASTIC SCREW GROMMET-BUMPER COVER; REAR QUARTER PANEL LINER RETAINER (FOR 8 MM SQ. HOLE; TAKES 5 MM (#10-#12) SCREW; 14 X 14 MM HEAD; 15 MM O/A HT) ACURA &amp; HONDA-'06-UP UNIT PKG.-15</b></p>	<p><b>874</b></p>  <p><b>TUBULAR CLIPS 3/32" STUD 0.120" HOLE CHRYSLER UNIT PKG.-100</b></p>	<p><b>875</b></p>  <p><b>(CHRY.-355891; FORD-600020) TUBULAR CLIPS 1/8" STUD; 0.161" HOLE GM, FORD, CHRYSLER UNIT PKG.-100</b></p>
--	---	---	---

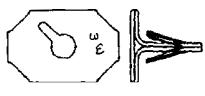
<p><b>878</b></p>  <p><b>TUBULAR CLIPS 3/16" STUD FOR 7/32" HOLE UNIVERSAL UNIT PKG.-100</b></p>	<p><b>879</b> (6000752) (374684-S32)</p>  <p><b>TUBULAR CLIPS 3/16" STUD ( #10 THREAD) 0.290-0.312" HOLE CHRYSLER &amp; FORD UNIT PKG.-100</b></p>	<p><b>2245</b> (4006316)</p>  <p><b>TUBULAR CLIPS- PLASTIC 1/8" STUD, 3/16" HOLE UNIVERSAL UNIT PKG.-100</b></p>	<p><b>2982</b> (06505049AA)</p>  <p><b>UNTHREADED STUD RETAINER FENDER MOULDING FOR 5 MM STUD, 24 MM O.D. PLATED JEEP- '97 &amp; UP UNIT PKG.-50</b></p>
---	---	---	---











<p><b>2400</b> (10056725)</p>  <p><b>METAL PANEL FASTENER DOOR PULL STRAP &amp; REAR SPEAKERS (#8 SCREW), (8 MM SQUARE HOLE) GM-'88 &amp; UP UNIT PKG.-25</b></p>	<p><b>2879</b></p>  <p><b>(06036042 AA) DOOR SILL NUT FOR #8 SCREW (9 X 13 MM HEAD) (10.5 MM OVERALL LENGTH) CHRYSLER- '99 &amp; UP UNIT PKG.-25</b></p>	<p><b>2304</b></p>  <p><b>(5114-1852-899) PLASTIC INSIGNIA CLIP BMW UNIT PKG.-25</b></p>
---	---	--

THREADED INSERTS-STEEL PLATED					THREADED INSERTS- HEXAGONAL HOLE STEEL, PLATED		
PART #	THREAD SIZE	HOLE SIZE	PANEL RANGE	UPKG.	PART #	THREAD SIZE	PANEL RANGE
2154	10-24	9/32"	.03-.165"	25	2903	1/4-20	.03-.165"
2155	1/4-20	3/8"	.03-.165"	25	(For 3/8" Hole; 1/2" Hd Diam. )		
2156	5/16-18	1/2"	.03-.165"	10	3300	4 MM	2.0-3.3 MM
5974	4 MM	6.75 MM	0.5-2.0 MM	25	(for 6.35 MM hole; 10 MM Hd Diam.)		
3149	5 MM	7.6 MM	0.5-3.3 MM	25	3085	5 MM	0.5-3.3 MM
5942	6 MM	10.0MM	0.7-4.2 MM	15	(for 7 MM hole; 10 MM Hd Diam.)		
5943	8 MM	13.5MM	0.7-3.8 MM	10	2904	6 MM	0.7-4.2 MM
5944	10 MM	13.5MM	0.7-3.8 MM	10	(for 9.5 MM hole; 13 MM Hd Diam.) EACH UNIT PKG.-15		

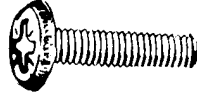

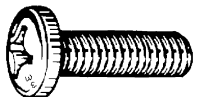
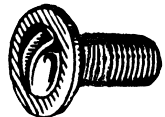
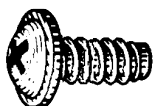

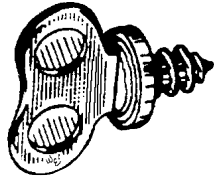
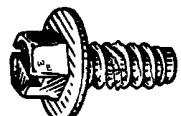
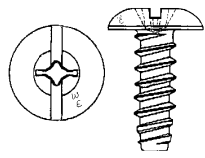

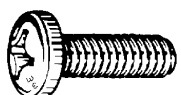
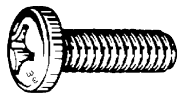



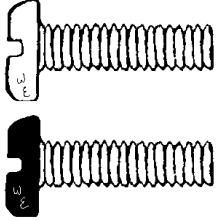

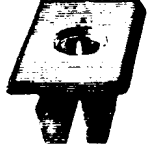
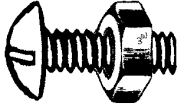
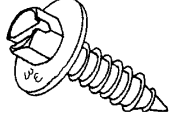

## LICENSE PLATES SCREWS AND BOLTS

<p><b>537</b> </p> <p>#14 X 3/4" SLOTTED PAN HEAD SCREW-ZINC PLATED (FOR LICENSE PLATES) UNIT PKG.-100</p>	<p><b>2326</b> </p> <p>#14 X 5/8" SPECIAL LICENSE PLATE SCREW-SLOTTED ROUND WASHER HEAD (9/16")-BLUNT POINT FOR USE WITH PLASTIC LICENSE PLATE NUTS (W&amp;E #S 818,826)-ZINC UNIT PKG.-100</p>	<p><b>2547</b> </p> <p>#14 X 3/4" SLOTTED TRUSS HEAD SCREW-ZINC PLATED (FOR LICENSE PLATES) UNIT PKG.-100</p>	
<p><b>2203</b> </p> <p>#14 X 3/4" SLOTTED HEX WASHER HEAD TAPPING SCREW TYPE-AB, ZINC PLATED (FOR LICENSE PLATES) USE WITH #818, 826 UNIT PKG.-50</p>	<p><b>5959</b> </p> <p>6 X 20 MM PHILLIPS PAN HEAD LICENSE PLATE BOLT- FORD ZINC/YELLOW PLATED UNIT PKG.-50</p>	<p><b>2704</b> </p> <p>LICENSE PLATE SCREW IMPORTS &amp; UNIVERSAL #10 X 5/8" PHILLIPS TRUSS HEAD SHEET METAL SCREW BLACK UNIT PKG.-100</p>	<p><b>3329</b> </p> <p>6-1.0 X 20 MM PHILLIPS PAN HEAD MACHINE SCREW (LIC. PLATE SCREW) STAINLESS STEEL UNIT PKG.-25</p>
<p><b>5960</b> </p> <p>6 X 16 MM SLOTTED WASHER PAN HEAD LICENSE PLATE BOLT ZINC PLATED UNIT PKG.-50</p>	<p><b>2779</b> </p> <p>6.3-1.81 X 16 MM (#14X5/8") PHILLIPS WASHER HEAD SHEET METAL SCREW (13.5 MM WASHER DIAM.) LICENSE PLATE-JAPANESE CARS ZINC/YELLOW UNIT PKG.-50</p>	<p><b>2663</b> </p> <p>LICENSE PLATE SCREW #14 X 3/4" SLOTTED TRUSS HEAD SHEET METAL SCREW-A; ZINC/BLACK UNIT PKG.-100</p>	
<p><b>2444</b> </p> <p>DEALER LICENSE PLATE THUMB SCREW #14 X 1/2" (1-1/4" OVERALL LENGTH) ZINC DIECAST UNIT PKG.-15</p>	<p><b>2446</b> </p> <p>(N 800369-S2) LICENSE PLATE SCREW 1/4"-14 X 5/8" SLOTTED HEX WASHER HEAD-5/16" HEX 5/8" WASHER DIAM. FORD PRODUCTS BLACK UNIT PKG.-50</p>	<p><b>2895</b> (9423101) </p> <p>6.3-1.81 X 16 MM COMBO HEAD (PHILLIPS/SLOTTED) SHEET METAL SCREW-B ZINC PHOSPHATE PLATED (500 HR SALT SPRAY) GM UNIT PKG.-50</p>	
<p><b>3147</b> (REPL. 16502342) </p> <p>6.3-1.81 X 30 MM, (#14X1-3/16") SLOTTED TRUSS HEAD LICENSE PLATE SCREW GM-S&amp;T TRUCKS &amp; UNIVERSAL BLACK(500 HR.SALT SPRAY) UNIT PKG.-50</p>	<p><b>3221</b> </p> <p>6-1.0 X 16 MM PHILLIPS PAN HEAD MACHINE SCREW (LIC. PLATE SCREW)-DIN 7985 ZINC PLATED UNIT PKG.-50</p>	<p><b>3243</b> </p> <p>6-1.0 X 16 MM PHILLIPS PAN HEAD LICENSE PLATE SCREW STAINLESS STEEL UNIT PKG.-25</p>	

## LICENSE PLATES SCREWS, BOLTS & NUTS

<p><b>2661</b> (NATURAL) <b>2662</b> (BLACK)</p>  <p style="text-align: center;">NYLON LICENSE PLATE SCREW 6 X 20 MM SLOTTED PAN HEAD (12 MM HEAD DIAMETER) EACH UNIT PKG.-100</p>	<p style="text-align: center;">BLACK NYLON LICENSE PLATE SCREW SLOTTED PAN HEAD (12 MM HEAD DIAM.)</p> <p><b>3180</b>-6 X 12 MM </p> <p><b>3181</b>-6 X 16 MM </p> <p style="text-align: center;">EACH UNIT PKG.-100</p>	<p><b>2772</b> (USE WITH W&amp;E #2661) NATURAL </p> <p><b>2773</b> (USE WITH W&amp;E #2662, #3180, #3181) BLACK</p> <p style="text-align: center;">6 MM NYLON HEX NUT (10 MM HEX) EACH UNIT PKG.-100</p>
<p><b>818</b> (3907444) (379046-S)</p>  <p style="text-align: center;">LICENSE PLATE NUT UNIVERSAL (USE #14 SCREWS) (W&amp;E 537, 2203, 2326, 2547) UNIT PKG.-50</p>	<p><b>826</b></p>  <p style="text-align: center;">(1196781), (4755299) GRILLE TO RADIATOR NUT LICENSE PLATE NUT HEADLAMP ADJUSTING NUT #14 SCREW-GM, FORD UNIT PKG.-50</p>	<p><b>963</b></p>  <p style="text-align: center;">1/4-20 X 5/8" SLOTTED TRUSS HEAD SCREW WITH HEX NUT- ZINC UNIT PKG.-100</p>
<p><b>3084</b></p>  <p style="text-align: center;">6.3-1.81 X 16 MM (#14 x 5/8") SLOTTED INDENTED HEX WASHER HEAD LICENSE PLATE SCREW-AB 8 MM (5/16") HEX, 16 MM (5/8") WASHER DIAM. FORD BLACK (500 HR. SALT SPRAY) UNIT PKG.-50</p>	<p><b>3090</b></p>  <p style="text-align: center;">(TOYOTA-93904-46320) (HONDA-91500-SM4-999AA) 6-1.81 X 20 MM PHILLIPS HEX WASHER HEAD LICENSE PLATE SCREW (#14 X 3/4"; 10 MM HEX 13 MM WASHER) ZINC/YELLOW UNIT PKG.-50</p>	<p><b>3183</b></p>  <p style="text-align: center;">#14 X 3/4" PHILLIPS TRUSS HEAD SHEET METAL SCREW FOR LICENSE PLATES ZINC PLATED UNIT PKG.-100</p>

## SPECIALIZED MOUNTING HARDWARE

<p><b>2525</b></p>  <p style="text-align: center;">6-1.0 X 26 MM STAINLESS STEEL PHILLIPS OVAL HEAD MACHINE SCREW (#10 HEAD) FOR MIRROR &amp; ROOF RACK INSTALLATION UNIT PKG.-25</p>	<p><b>2527</b></p>  <p style="text-align: center;">1/4"-20 X 1" STAINLESS STEEL PHILLIPS OVAL HEAD MACHINE SCREW (#10 HEAD) FOR MIRROR &amp; ROOF RACK INSTALLATION UNIT PKG.-25</p>	<p><b>2836</b></p>  <p style="text-align: center;">5-0.8 X 26 MM STAINLESS STEEL PHILLIPS OVAL HEAD MACHINE SCREW FOR MIRROR &amp; ROOF RACK INSTALLATION UNIT PKG.-25</p>
--	---	---

**SPECIALIZED MOUNTING HARDWARE**

**2906**  
(20130258)



**"WELL NUT" FOR ATTACHING ROOF/LUGGAGE RACKS 6 MM SCREW SIZE, 13 MM HOLE 20 MM FLANGE DIAMETER (LARGER FLANGE THAN W&E #2524) UNIT PKG.-10**

**2907**

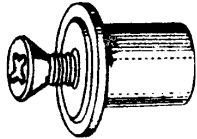

**ROOF/LUGGAGE RACK ASSEMBLY 6 MM WELL NUT WITH 20 MM FLANGE, PLATED MACHINE SCREW AND FLAT WASHER UNIT PKG.-10**

**2272**



(OE-6027941)  
1/4"-20 X 7/8"  
**PHILLIPS OVAL HEAD MACHINE SCREW (TRIM HEAD) DECK LID LUGGAGE RACK AND SIDE VIEW MIRROR UNIT PKG.-25**

**2285**



(GM-342271)  
"WELL NUT"  
1/4"-20 SCREW SIZE; 1/2" HOLE FOR ATTACHING ROOF RACK OR MIRRORS NEOPRENE WITH CAPTIVE BRASS NUT UNIT PKG.-10

**2524**

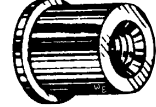

(GM-15505451, AMC-8934201293)  
6 MM SCREW SIZE; 13 MM HOLE 16 MM HEAD DIAMETER "WELL NUT" -FOR ATTACHING ROOF RACK OR MIRRORS NEOPRENE WITH CAPTIVE BRASS NUT UNIT PKG.-10

**2810**



(REPLACES-10137292, 22520368) (140050597)  
"WELL NUT"  
5 MM SCREW SIZE; 14.3 MM HEAD, FOR 9.5 MM HOLE;NEOPRENE WITH CAPTIVE BRASS NUT FOR ATTACHING ROOF RACK AND LUGGAGE MOUNT UNIT PKG.-10

**2324**

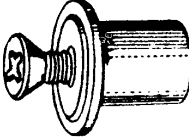

**ROOF RACK/ LUGGAGE MOUNT ASSEMBLY; (1/4"-20 WELL NUT STAINLESS STEEL MACHINE SCREW, FLAT WASHER) UNIT PKG.- 10**

**2526**



**ROOF RACK/ LUGGAGE MOUNT ASSEMBLY; (6 MM WELL NUT STAINLESS STEEL MACHINE SCREW, FLAT WASHER) UNIT PKG.- 10**

**2837**

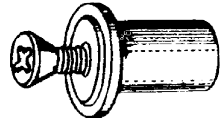

**ROOF RACK/ LUGGAGE MOUNT ASSEMBLY; 5 MM WELL NUT, STAINLESS STEEL MACHINE SCREW, FLAT WASHER) UNIT PKG.- 10**

**2183**

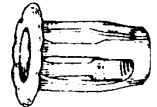

(14005953), (367292)  
1/4"-20 JACK NUT LICENSE PLATE & MIRROR MOUNTING UNIVERSAL UNIT PKG.-25

**2522**

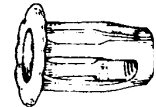

(5970995), (10014363)  
6 MM JACK NUT LICENSE PLATE & MIRROR MOUNTING UNIVERSAL UNIT PKG.-25

**2161**



1/4"-20 X 1"  
HEX WASHER HEAD MACHINE SCREW (USE WITH W&E #2183) ZINC PLATED UNIT PKG.-50

**2432**  
(367292) (6031438)

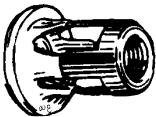

1/4"-20 COATED JACK NUT ROOF RACK MOUNT GM, CHRYSLER & UNIVERSAL UNIT PKG.-10



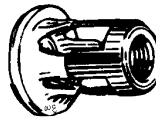







**2433**  
(14007940)

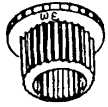

6 MM COATED JACK NUT ROOF RACK MOUNT GM & UNIVERSAL UNIT PKG.-10

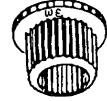

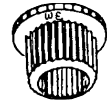
## DOOR HINGE BUSHINGS AND CLIPS

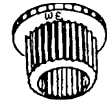
<p><b>2281</b></p>  <p>(9721917)  <b>DOOR HINGE BUSHING</b>                      (.344"-I.D.), (.421"-O.D.)                      (.296" OVERALL HEIGHT)                      (USE WITH #2357)-GM                      BRONZE                      UNIT PKG.-15</p>	<p><b>2282</b></p>  <p>(9716926), (20345137)  <b>DOOR HINGE BUSHING</b>                      (.341"-I.D.) (.490"-O.D.)                      (.358" OVERALL HEIGHT)                      GM-(A,B,F,J,BODIES) TRUCKS &amp; VANS                      BRONZE                      UNIT PKG.-15</p>	<p><b>2283</b>                      (9822198)</p>  <p><b>DOOR HINGE BUSHING</b>                      (.382"-I.D.)                      (.504"-O.D.)                      (.460" OVERALL HEIGHT)                      GM-BRONZE                      UNIT PKG.-15</p>
<p><b>2284</b>                      (20429500)</p>  <p><b>DOOR HINGE BUSHING</b>                      (.344"-I.D.) (.494"-O.D.)                      (.360" OVERALL HEIGHT)                      GM(A,B,F,J BODIES)                      TRUCKS &amp; VANS                      (USE WITH #2358 OR #2944)                      BRONZE                      UNIT PKG.-15</p>	<p><b>2327</b></p>  <p>(D90Z-6522841A)                      (D20B-6522841AA)  <b>DOOR HINGE BUSHING</b>                      (.346"-I.D.) (.477"-O.D.)                      (.293" OVERALL HEIGHT)-BRONZE                      FORD- '79 &amp; UP                      (USE WITH #2943)                      UNIT PKG.-15</p>	<p><b>2457</b>                      (2486468)</p>  <p><b>DOOR HINGE BUSHING</b>                      (.346"-I.D.) (.419"-O.D.)                      (.444" OVERALL HEIGHT)                      CHRYSLER VANS                      BRONZE                      UNIT PKG.-15</p>
<p><b>3151</b></p> <p style="text-align: center;"><b>DOOR HINGE BUSHING</b>                      (.494" O.D.) (.376" I.D.), (.250" OVERALL HEIGHT)                      CHRYSLER (DODGE, PLYMOUTH) 1984-1995                      BRONZE (USE WITH W&amp;E #2635)                      UNIT PKG.-15</p> 		<p><b>2740</b></p>  <p>(15562609, 15964972), (16632192)  <b>DOOR HINGE BUSHING-UPPER</b>                      (.391"-I.D.) (.532"-O.D.)                      (.359" OVERALL HEIGHT)                      GM TRUCKS- '88 &amp; UP                      (USE WITH W&amp;E #2714 OR #2896)                      BRONZE                      UNIT PKG.-15</p>
<p><b>2637</b>                      (4336115)</p>  <p><b>DOOR HINGE BUSHING</b>                      (.252"-I.D.), (.371"-O.D.)                      (.391" OVERALL HEIGHT)-BRONZE                      CHRYSLER-'86 &amp; UP                      UNIT PKG.-15</p>	<p><b>2639</b>                      (80410-01G00)</p>  <p><b>DOOR HINGE BUSHING</b>                      (8 MM-I.D.), (10 MM-O.D.)                      (10.5 MM OVERALL HEIGHT)-BRONZE                      NISSAN TRUCKS-'85 &amp; UP                      (USE WITH W&amp;E #2638)                      UNIT PKG.-6</p>	<p><b>2741</b></p>  <p>(12338074, 15964971)                      (15691493, 16632193)  <b>DOOR HINGE BUSHING-LOWER</b>                      (.344"-I.D.)                      (.484"-O.D.)                      (.359" OVERALL HEIGHT)                      GM TRUCKS-'88 &amp; UP                      (USE WITH W&amp;E #2714 OR #2986)                      BRONZE                      UNIT PKG.-15</p>
<p><b>3160</b></p>  <p>(GM-15994486)  <b>DOOR HINGE BUSHING</b>                      (.404"-I.D.;.492"-O.D.)                      (.356" OVERALL HEIGHT)                      (USE WITH #3159; IN KIT #3164)                      STAMPED STEEL                      UNIT PKG.-15</p>	<p><b>3154</b></p>  <p><b>DOOR HINGE BUSHING</b>                      (.320"-I.D.;.408"-O.D.)                      (.219" OVERALL HEIGHT)                      JEEP (CHEROKEE) 1984-1999                      (USE WITH #3153;-IN KIT #3163)                      STAMPED STEEL                      UNIT PKG.-15</p>	<p><b>2741</b></p>  <p>(12338074, 15964971)                      (15691493, 16632193)  <b>DOOR HINGE BUSHING-LOWER</b>                      (.344"-I.D.)                      (.484"-O.D.)                      (.359" OVERALL HEIGHT)                      GM TRUCKS-'88 &amp; UP                      (USE WITH W&amp;E #2714 OR #2986)                      BRONZE                      UNIT PKG.-15</p>

## DOOR HINGE PINS

**DRP-1**

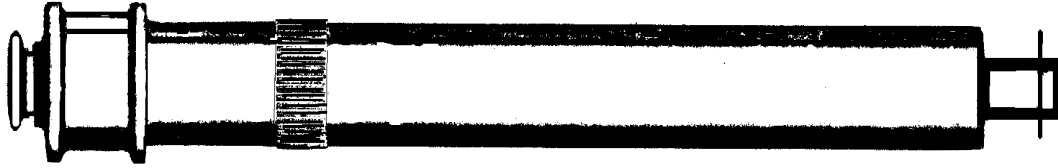

DOOR ROLLER PIN ASSEMBLY- GM CK 1,2,3 TRUCKS- '88 & UP (NOT AVAILABLE THROUGH OEM)  
(MAJOR DIAMETER-9/16"; OVERALL LENGTH- 5-1/2")  
UNIT PKG.-1

**2714**



(OE 15591860, 15691595, 15967691, 15685040)  
DOOR HINGE PIN(STAINLESS STEEL)-11/32" X 5-1/4"; SHOULDER DIAM. 3/8"  
GM TRUCKS- '88 & UP (USE WITH #2740 AND #2741)  
UNIT PKG.-4

**2357**



(OE 6271989, 20046147)  
DOOR HINGE PIN-11/32" X 4-1/8"; HEAD DIAMETER 9/16"  
GM CARS & TRUCKS (USE WITH #2281)  
UNIT PKG.-8

**2358**

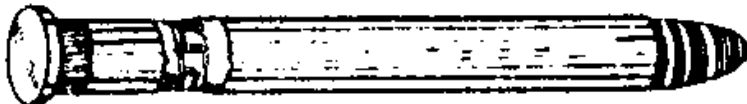

(OE 20043351)  
DOOR HINGE PIN-11/32" X 4"  
GM CARS-'81-'84 & UP (CITATION, T-100, CHEVETTE) (USE WITH #2284)  
UNIT PKG.-4

**2359**

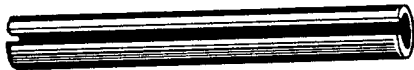

(OE 6500361)  
DOOR HINGE PIN-1/4" X 2-5/32"  
CHRYSLER-'80 & UP  
UNIT PKG.-12

**2360**



(OE 6028993, 6032975)  
DOOR HINGE PIN-1/4" X 2-5/8"  
DODGE & PLYMOUTH VANS-'70 & UP  
UNIT PKG.-8

**2635**

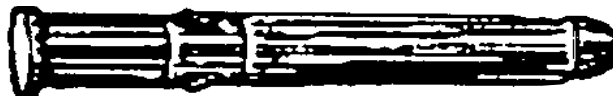

(OE 4280727, 5505125)  
DOOR HINGE PIN-3/8" X 3-1/8" CHRYSLER-'84 & UP  
UNIT PKG.-6

## DOOR HINGE PINS

**2638**  
(OE 80406-V5002)

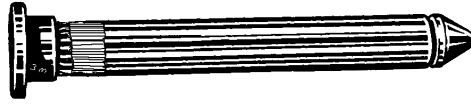

DOOR HINGE PIN-8 X 72 MM  
(INCLUDES 1/4" "E" CLIP)  
USE WITH W&E #2639  
NISSAN TRUCKS- '85 & UP  
UNIT PKG.-5

**2896**



(OE 15653790), (15646148)  
DOOR HINGE PIN-11/32" X 4-1/8"  
HEAD DIAMETER 1/2"(SHOULDER DIAM.-3/8")  
ZINC/YELLOW  
(USE WITH BUSHINGS-#2740 AND #2741), (USE WITH W&E #2753 OR #2647)  
GM S&T TRUCKS-'94 & UP  
UNIT PKG.-4

**2943**  
(E8UZ1522840)



DOOR HINGE PIN  
11/32" O.D., 3-1/2" LONG (USE WITH W&E #2327& #2648)  
FORD TRUCKS-'85 & UP- ZINC/YELLOW PLATED  
UNIT PKG.-5

**2944**

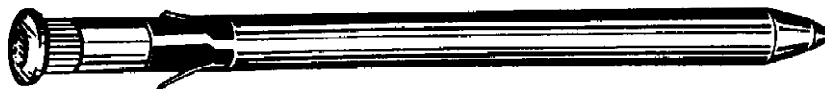

(12338015, 14066728)  
DOOR HINGE PIN- 11/32" O.D., 4-1/8" LONG  
USE WITH W&E # 2284  
GM, ASTRO SAFARI VANS, S-10 TRUCKS-'82 & UP- ZINC/YELLOW PLATED  
UNIT PKG.-5

**3152**

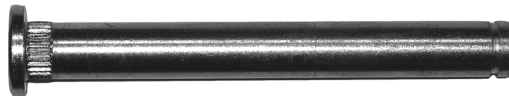

DOOR HINGE PIN  
11/32" X 2-3/4" WITH 9/16" HEAD DIAMETER  
FORD- VARIOUS CARS, TRUCKS, VANS-1994 & UP  
USE WITH W&E # 2741 & #2648 ( IN KIT- W&E # 3162)  
UNIT PKG.-4

## DOOR HINGE PINS, KITS, CLIPS

**3153**



**DOOR HINGE PIN**  
 5/16" X 2-35/64"  
 7/16" HEAD DIAMETER  
 JEEP (CHEROKEE)-1984-1999  
 (USE WITH #3154, #3158, #2647)  
 (IN KIT #3163)  
 UNIT PKG.-4

**3159**



**DOOR HINGE PIN**  
 3/8" X 3"  
 21/32" HEAD DIAMETER-ZINC  
 GM FULL SIZE VANS  
 (USE WITH W&E #3160, IN KIT #3164)  
 UNIT PKG.-4

**3161**



(D9ZZ-6643030-AA)  
**DOOR HINGE PIN**  
 11/32" X 3-15/32", 9/16" HEAD DIAMETER-ZINC  
 FORD-MUSTANG, TEMPO, TOPAZ, CAPRI-'79-'94  
 (USE WITH W&E #2327; IN KIT #3165)  
 UNIT PKG.-5

**3163**

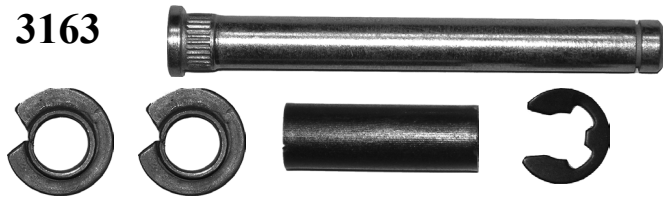

**DOOR HINGE PIN & BUSHING KIT**  
 JEEP (CHEROKEE)-1984-1999  
 (CONTAINS 2 EA.#3153, 4 EA.-#3154  
 2 EA.-#3158 AND 2 EA.-#2647)  
 UNIT PKG.-1 SET

**3162**

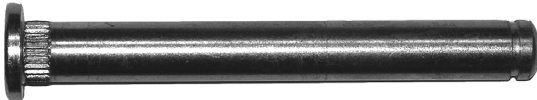

**DOOR HINGE PIN & BUSHING KIT**  
 FORD- VARIOUS CARS, TRUCKS, VANS-1994 & UP  
 ( CONTAINS 2 EA.-#3152, 4 EA.-#2741 and 2 EA.#2648)  
 UNIT PKG.-1 SET

**3165**



**HINGE PIN AND BUSHING SET**  
 FORD-MUSTANG, TEMPO, TOPAZ, CAPRI  
 1979-1994  
 (CONTAINS 2 EA.-W&E #3161 & 4 EA.-W&E #2327)  
 UNIT PKG.-1 SET

**3158**

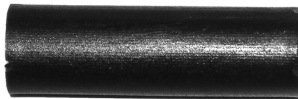

**DOOR HINGE PIN**  
 SLEEVE  
 JEEP-CHEROKEE  
 1984-1999  
 (USE WITH #3153 IN KIT #3163)  
 UNIT PKG.-10

**2600**

(OE 4280729)



**HINGE PIN CLIP**  
 (I.D.-8.3 MM,  
 OVERALL HEIGHT-  
 9.85 MM)  
 CHRYSLER- '80 & UP  
 ZINC DICHROMATE  
 UNIT PKG.-25

**2753**

(15562610)

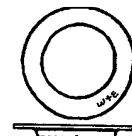

**DOOR HINGE PIN CLIP**  
 GM C-K TRUCKS-'88 & UP  
 (USE WITH W&E #2714)  
 STAINLESS STEEL  
 UNIT PKG.-50

## DOOR HINGE PINS AND BUSHING SETS

**2949**



**FORD TRUCKS DOOR HINGE PIN AND BUSHING SET**  
 (CONSISTS OF TWO EACH HINGE PINS, FOUR BUSHINGS AND TWO "E" CLIPS)  
 (W&E #S 2943, 2327 AND 2648)  
**UNIT PKG.-1 SET**

**2901**

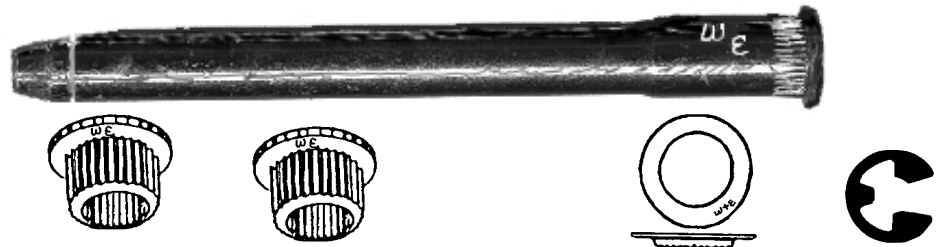

**GM S&T TRUCKS - HINGE PIN, BUSHING AND RETAINER SET**  
 (CONSISTS OF TWO EACH- UPPER & LOWER BUSHINGS, RETAINERS, "E" CLIPS AND HINGE PINS)  
 (W&E #S 2896,2740,2741, 2753 & 2648)  
**UNIT PKG.-1 SET**

**2950**



**GM ASTRO SAFARI VAN AND S-10 TRUCK DOOR HINGE PIN AND BUSHING SET**  
 (CONSISTS OF TWO EACH HINGE PINS AND FOUR BUSHINGS)  
 (W&E #S 2944 AND 2284)  
**UNIT PKG.-1 SET**

**2994**



**GM FULL SIZE VANS '78-'96 DOOR HINGE PIN & BUSHING SET**  
 (CONSISTS OF TWO EACH HINGE PINS & RETAINERS AND FOUR EACH BUSHINGS)  
 (W&E #S 2357, 2753, 2281)  
**UNIT PKG.-1 SET**

**3148**

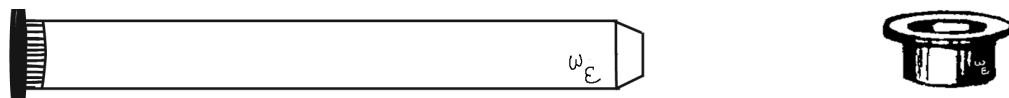

**DOOR PIN AND BUSHING KIT**  
 (PIN-OE 55076192; BUSHING-OE 55074591)  
**FRONT DOOR**  
**1994-1998 JEEP GRAND CHEROKEE**  
 (CONTAINS TWO PINS AND FOUR BUSHINGS)  
**UNIT PKG.-1 SET**



## DOOR HINGE PINS AND BUSHING SETS

**2748**

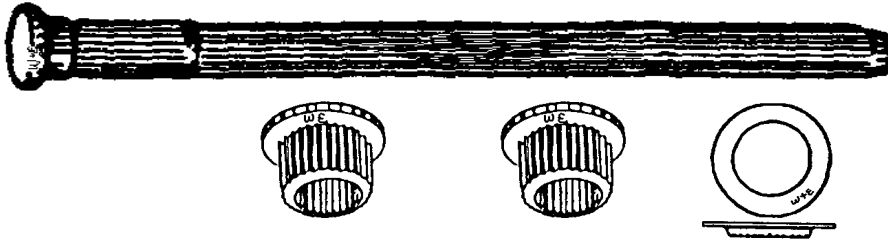

**GM FULL SIZE TRUCKS-HINGE PIN, BUSHING,  
AND RETAINER SET-'88-'98**

(CONSISTS OF TWO OF EACH PART- UPPER, LOWER BUSHINGS, RETAINERS AND HINGE PINS)  
(CONTAINS W&E PART #S: #2714, #2740, #2741, #2753)

**UNIT PKG.-1 SET**

**2995**

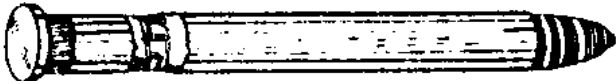
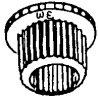

**OLDS CUTLASS CIERRA -'82-'96  
HINGE PIN AND BUSHING SET**

(CONSISTS OF TWO EACH HINGE PINS AND FOUR  
EACH BUSHINGS) (W&E #S 2358 AND 2284)

**UNIT PKG.-1 SET**

**3164**

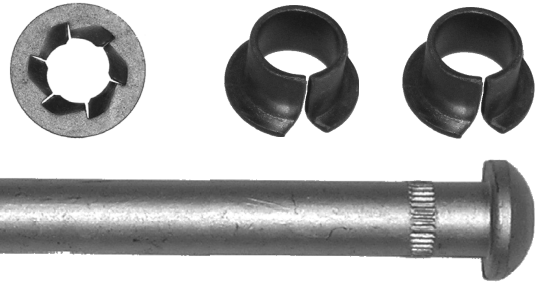

**DOOR PIN AND BUSHING KIT  
GM FULL SIZE VANS, HINGED SIDE DOOR  
CHEVY EXPRESS/GMC SAVANA -1996-2006  
(CONTAINS TWO PINS, FOUR BUSHINGS  
AND TWO RETAINERS)**

**UNIT PKG.-1 SET**

**3070**

**DOOR HINGE  
REPAIR  
KIT**

(THREADED PINS &  
NYLOK NUTS)



**GM C & K TRUCKS  
1999 & UP**

CONSISTS OF TWO EACH LONG AND SHORT  
PINS, FOUR BUSHINGS,  
TWO WASHERS  
AND FOUR NUTS  
(HINGE NOT INCLUDED)

KIT CONTAINS PARTS TO COMPLETE  
ONE DOOR (UPPER AND LOWER HINGE)

**UNIT PKG.-1 SET**

**3071 DODGE HINGE PIN & BUSHING KIT**

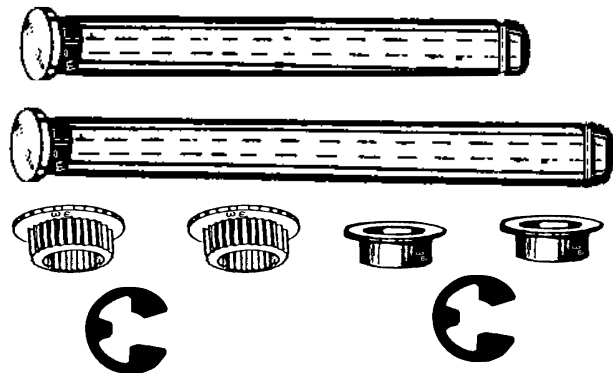

(CONSISTS OF TWO PINS, FOUR BUSHINGS  
AND TWO "E" CLIPS)

**DODGE RAM PICK UP-'97 & UP  
DODGE DAKOTA-'97 & UP**

**UNIT PKG.-1 SET**

**WASHERS, FINISHING, TOOTHED, FLUSH  
MACHINE SCREWS, COTTER PINS**

**COUNTERSUNK FINISHING WASHERS  
STEEL**

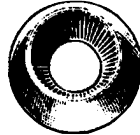
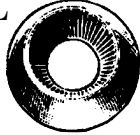

<u>PART #</u>	<u>SCREW SIZE</u>	<u>PLATED</u>
1036	#6	NICKEL
1037	#8	NICKEL
1038	#10	NICKEL
1039	#12	NICKEL
2515	#6	BLACK
2518	#12	BLACK

EACH UNIT PKG.-100

**FLUSH TYPE  
FINISHING WASHERS  
(BRASS, NICKEL PLATED)**



<u>PART #</u>	<u>SCREW SIZE</u>
1042	#6
1044	#10

EACH UNIT PKG.-100

**STEEL COTTER PINS  
ZINC PLATED**



<u>PART #</u>	<u>SIZE</u>	<u>UPKG.</u>
2167	1/16" x 1"	200
2168	3/32" x 1"	200
2793	3/32" x 2"	100
2169	1/8" x 1-1/2"	200
2170	1/8" x 2"	200
2171	5/32" x 1-1/2"	100
2172	5/32" x 2"	100

**TOOTHED LOCKWASHERS  
EXTERNAL TEETH**



<u>PART #</u>	<u>SCREW SIZE</u>
1061	#6
1062	#8
1063	#10
1064	#12
1065	#14

EACH UNIT PKG.-100

**MACHINE SCREWS PLATED**



<u>PART #</u>	<u>DESCRIPTION</u>	<u>UPKG.</u>
1411	8-32 X 1/2" SLOTTED ROUND HD	100
1415	10-24 X 1/2" SLOTTED ROUND HD	100
1420	10-32 X 1/2" SLOTTED ROUND HD	100
2158	10-24 X 3/4" PHILLIPS OVAL HD	100
2159	1/4"-20 X 3/4" PHILLIPS OVAL HD	50
2160	1/4"-20 X 1" PHILLIPS OVAL HD	50

**TOOTHED LOCKWASHERS  
INTERNAL TEETH**



<u>PART #</u>	<u>SCREW SIZE</u>
1071	#6
1072	#8
1073	#10
1074	#12
1075	#14
1077	3/8"
1078	7/16"
1079	1/2"

EACH UNIT PKG.-100

## SPECIAL PLASTIC PARTS

**810**

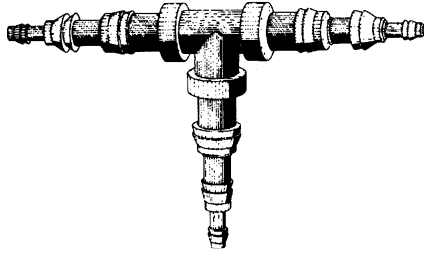

(PICTURE SMALLER THAN ACTUAL SIZE)  
**PLASTIC UNIVERSAL BREAK-OFF TEE**  
 FOR 1/8", 1/4" AND 3/8" TUBING  
 UNIT PKG.-5

**2146**



**UNIVERSAL TUBING CONNECTOR**  
 (BREAK OFF TYPE)  
 1/8" TO 1/4" TO 3/8"  
 GOES FROM ONE SIZE TO ANOTHER  
 UNIT PKG.-10

**2546**



(OE-25512081, 386132-S, 386132)  
**WIRING/TUBING CLIP**  
 1/4" DIAMETER TUBING  
 1/4" HOLE SIZE  
 GM, FORD, CHRYSLER  
 & UNIVERSAL  
 UNIT PKG.-25

**2289**

(OE-8911497)

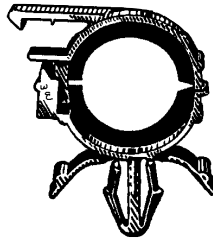

**CONVOLUTED**  
**WIRING HARNESS CLIP**  
 (.413" DIAMETER)  
 ALL GM CARS  
 UNIT PKG.-25

**2219**

(OE-8911472)

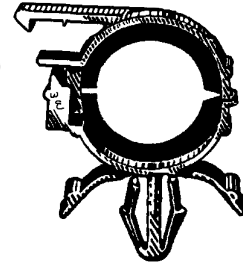

**CONVOLUTED**  
**WIRING HARNESS CLIP**  
 (.500" DIAMETER)-ALL GM CARS  
 UNIT PKG.-25

**2290**

(OE-8917320)  
 (3816659)

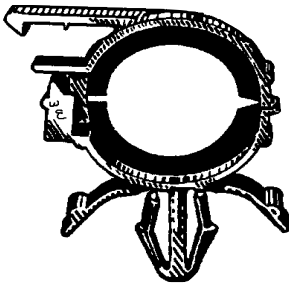

**CONVOLUTED**  
**WIRING HARNESS CLIP**  
 (.750" DIAMETER)  
 GM & UNIVERSAL  
 UNIT PKG.-25

**2854**

(12040984)

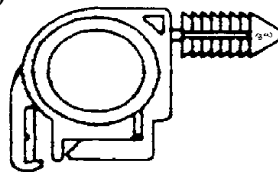

**CONVOLUTED WIRING**  
**HARNESS CLIP-3/8" DIAM.**  
 (USE WITH W & E #2553)  
 (1/4" HOLE)  
 GM & UNIVERSAL  
 UNIT PKG.-15

**2855**

(12040983)

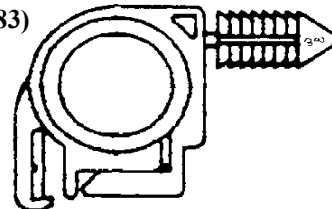

**CONVOLUTED WIRING**  
**HARNESS CLIP-1/2" DIAM.**  
 (USE WITH W & E #2555)  
 (1/4" HOLE)  
 GM & UNIVERSAL  
 UNIT PKG.-15

**2129**

(OE-6015930)

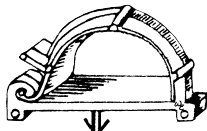

(PICTURE NOT ACTUAL SIZE)  
**SELF LOCKING & UNLOCKING UNIVERSAL**  
**PLASTIC PUSH-IN WIRE & HOSE RETAINER**  
 UNIT PKG.-10



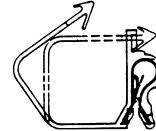

**2422**

(OE-N805940S)

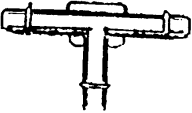

(PICTURE NOT ACTUAL SIZE)  
**WIRING CLIP- ANTILOCK BRAKES**  
 '89 T-BIRD, COUGAR & UNIVERSAL  
 UNIT PKG.-10

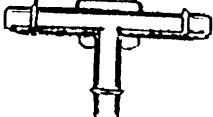
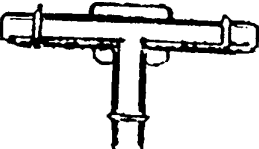
## SPECIAL PLASTIC PARTS

<p><b>2426</b> </p> <p>(357020, 6272766, 22508050) (373846-S, 3671410, 3673945) 3/16" X 3/16" X 3/16" <b>THREE WAY VACUUM TEE</b> GM, FORD, CHRYSLER &amp; UNIVERSAL UNIT PKG.-10</p>	<p><b>2427</b> </p> <p>(560625, 22508051, 383003) (389138, 4104998) 3/16" X 3/16" <b>CONNECTOR</b> GM, FORD, CHRYSLER &amp; UNIVERSAL UNIT PKG.-10</p>	<p><b>2430</b> </p> <p>(14017705, 3895904, 3751212) 1/8" X 1/8" X 1/8" <b>THREE WAY VACUUM TEE</b> GM, FORD, CHRYSLER &amp; UNIVERSAL UNIT PKG.-10</p>															
<p><b>2431</b> </p> <p>1/4" X 1/4" X 1/4" <b>THREE WAY VACUUM TEE</b> GM &amp; UNIVERSAL UNIT PKG.-10</p>	<p><b>3189</b> </p> <p>1/8" STRAIGHT <b>VACUUM CONNECTOR</b> UNIT PKG.-10</p>	<p><b>VACUUM CAPS</b> GM, FORD, CHRYSLER AND UNIVERSAL </p> <table border="1" style="width: 100%; border-collapse: collapse;"> <thead> <tr> <th style="text-align: left;"><u>PART #</u></th> <th style="text-align: left;"><u>SIZE</u></th> <th style="text-align: left;"><u>UNPKG.</u></th> </tr> </thead> <tbody> <tr> <td>2988</td> <td>1/8"</td> <td>25</td> </tr> <tr> <td>2428</td> <td>3/16"</td> <td>15</td> </tr> <tr> <td colspan="3">(REPLACES-380614-S)</td> </tr> <tr> <td>2989</td> <td>1/4"</td> <td>25</td> </tr> </tbody> </table>	<u>PART #</u>	<u>SIZE</u>	<u>UNPKG.</u>	2988	1/8"	25	2428	3/16"	15	(REPLACES-380614-S)			2989	1/4"	25
<u>PART #</u>	<u>SIZE</u>	<u>UNPKG.</u>															
2988	1/8"	25															
2428	3/16"	15															
(REPLACES-380614-S)																	
2989	1/4"	25															

**HOLE PLUGS- FLUSH TYPE**  
USED FOR PAINTLESS DENT REMOVAL  
AND RUSTPROOFING 

<u>PART #</u>	<u>HOLE SIZE</u>	<u>PANEL RANGE</u>	<u>UNIT PKG.</u>
2722	1/4"	.02-.07	100
2723	3/8"	.02-.05	100
2724	1/2"	.03-.08	100
2725	3/4"	.05-.11	100
2806	1"	.03-.08	50
2807	1-1/2"	.02-.08	25

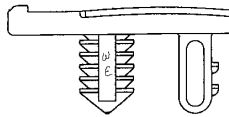
**3066** 

(E9DB-14A-163CA)  
**RETAINER-RELAY**  
FOR 6.3 MM HOLE  
HEAD SIZE-10 X 30 MM  
FORD

UNIT PKG.-25

**HOLE PLUGS-RECESSED HEAD**















USED FOR RUSTPROOFING AND PAINTLESS DENT  
REPAIR

<u>PART #</u>	<u>HOLE SIZE</u>	<u>PANEL THICKNESS</u>
2147	1/2"	.06-.13"
2702	3/4"	.02-.14"

EACH UNIT PKG.-100

**VTC-50**  
**VACUUM TEE AND CAP**  
**ASSORTMENT**

 <p>2426</p>  <p>(357020) (6272766) (22508050) (373846-S) (3671410) (3673945) 3/16" X 3/16" X 3/16" THREE WAY VACUUM TEE GM, FORD, CHRYSLER &amp; UNIVERSAL</p>	 <p>2427</p>  <p>(560625) (22508051) (383003) (389138) (4104998) 3/16" X 3/16" CONNECTOR GM, FORD, CHRYSLER &amp; UNIVERSAL</p>	 <p>2430</p>  <p>(14017705) (3895904) (3751212) 1/8" X 1/8" X 1/8" THREE WAY VACUUM TEE GM, FORD, CHRYSLER &amp; UNIVERSAL</p>	 <p>2431</p>  <p>1/4" X 1/4" X 1/4" THREE WAY VACUUM TEE GM &amp; UNIVERSAL</p>	 <p>2428</p>  <p>3/16" VACUUM CAP GM, FORD, CHRYSLER AND UNIVERSAL</p>	 <p>2988</p>  <p>1/8" VACUUM CAP GM, FORD, CHRYSLER AND UNIVERSAL</p> <p>2989</p>  <p>1/4" VACUUM CAP GM, FORD, CHRYSLER AND UNIVERSAL</p>
---	---	--	---	--	--

UNIT PKG.-1

## PLASTIC CABLE STRAPS

**988**



(1189106), (3750535), (6015149)  
**PLASTIC CABLE STRAP-3-5/8" LONG**  
 GM & CHRYSLER  
 UNIT PKG.-100

**989**



**WIRING STRAP**  
**UNIVERSAL**  
 2-3/4" LONG; FOR 1/4" HOLE  
 UNIT PKG.-50

**990**

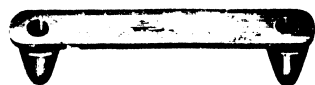

**WIRING STRAP**  
**UNIVERSAL**  
 2-3/4" LONG; FOR 1/4" HOLE  
 UNIT PKG.-50

**991**



**REUSABLE CABLE STRAP-HEAVY DUTY PLASTIC -9" LONG**  
 UNIT PKG.-25

**2120**

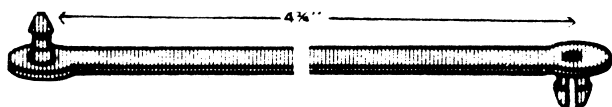

**WIRING STRAP-4-3/4" LONG**  
 FOR 1/4" HOLE; AMC & UNIVERSAL  
 UNIT PKG.-25

**2497**



(90672-SA-0-0030); (9928-91-053353)  
**REUSABLE CABLE STRAP**  
 (140 MM LONG, 7 MM HOLE)  
 HONDA, MAZDA  
 UNIT PKG.-20

**3323**

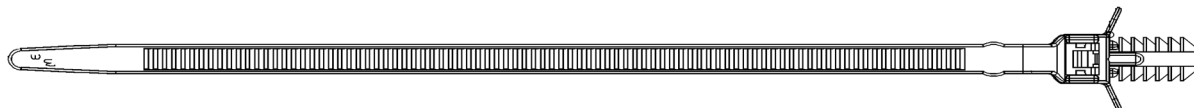

(OE# NOT AVAILABLE)  
**PUSH MOUNT CABLE TIE - BLACK**  
 FOR 6.3 MM HOLE (1/4") ; 156 MM OVERALL LENGTH (6.2")  
 BUNDLE DIAMETER MAXIMUM - 30 MM ; GM & UNIVERSAL  
 UNIT PKG.-25

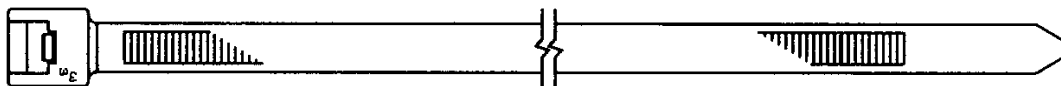

## NYLON CABLE STRAPS

<u>Part #</u>	<u>Color</u>	<u>Overall length</u>	<u>Bundle Diameter</u>	<u>Tensile Strength</u>	<u>Unit Pkg.</u>
2865	BLACK	4"	UP TO 7/8"	18 lb.	100
2102	NATURAL	5"	UP TO 1-1/8"	40 lb.	50
2126	NATURAL	7-1/2"	UP TO 1-3/4"	50 lb.	50
2385	BLACK	7-1/2"	UP TO 1-3/4"	50 lb.	50
2269	NATURAL	11"	UP TO 3"	50 lb.	25
2386	BLACK	11"	UP TO 3"	50 lb.	25
2770	NATURAL	14"	UP TO 4"	50 lb.	25
2771	BLACK	14"	UP TO 4"	50 lb.	25

## SOLDERLESS TERMINALS- INSULATED

### RING TONGUES

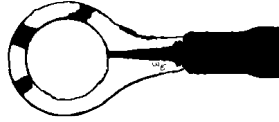

<u>PART #</u>	<u>WIRE SIZE</u>	<u>STUD SIZE</u>	<u>COLOR</u>	<u>UNIT PKG</u>
421	#22-18	#8-10	RED	50
424	#16-14	#8-10	BLUE	50
425	#16-14	#12-1/4"	BLUE	50
426	#16-14	5/16"-3/8"	BLUE	50
427	#12-10	#8-10	YELLOW	50
428	#12-10	#12-1/4"	YELLOW	50
429	#12-10	5/16"-3/8"	YELLOW	50
430	#12-10	7/16"-1/2"	YELLOW	25

### SPADE TONGUES

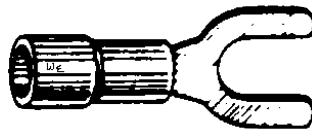

<u>PART #</u>	<u>WIRE SIZE</u>	<u>STUD SIZE</u>	<u>COLOR</u>	<u>UNIT PKG</u>
432	#22-18	#8-10	RED	50
433	#16-14	#8-10	BLUE	50
434	#12-10	#8-10	YELLOW	50

### HOOK- TONGUE



<u>PART #</u>	<u>WIRE SIZE</u>	<u>STUD SIZE</u>	<u>COLOR</u>	<u>UNIT PKG</u>
437	#16-14	#8-10	BLUE	50

### BUTT CONNECTORS (NYLON)



<u>PART #</u>	<u>WIRE SIZE</u>	<u>COLOR</u>
440	#22-18	RED
441	#16-14	BLUE
442	#12-10	YELLOW

EACH UNIT PKG.-50



FEMALE QUICK DISCONNECT  
#16-14 WIRE-BLUE  
UNIT PKG.-50



MALE QUICK DISCONNECT  
#16-14 WIRE-BLUE  
UNIT PKG.-50



DEAD END CONNECTOR  
(NYLON) #22-14 WIRE  
UNIT PKG.-50



DEAD END CONNECTOR  
(NYLON) #16-10 WIRE  
UNIT PKG.-50



STOP LIGHT CONNECTOR  
#16-14 WIRE  
(USE WITH W&E #449)  
UNIT PKG.-50

455



DISCONNECT  
FEMALE-DOUBLE MALE  
ADAPTER-1/4" TAB  
UNIT PKG.-50

449



SNAP PLUG  
#16-14 WIRE  
(USE WITH W&E #448&#453)  
UNIT PKG.-50

## ELECTRICAL CONNECTORS

**450**

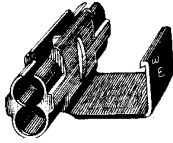

**QUICK ELECTRIC CONNECTOR**  
 #16-14 WIRE (BLUE)  
 SELF STRIPPING-CAPABLE  
 OF MAKING TAP, IN-LINE, AND  
 PIGTAIL SPLICES  
 ONE PRESS OF PLIERS STRIPS  
 AND CONNECTS FLAPS SNAP IN  
 PLACE FOR INSULATION  
 UNIT PKG.-25

**3134**

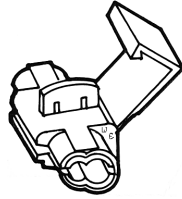

**SELF STRIPPING QUICK  
 CONNECT**  
 #22-18 WIRE (RED)  
 UNIT PKG.-25

**3135**

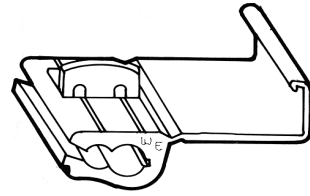

**SELF STRIPPING QUICK  
 CONNECT**  
 #12-10 WIRE (YELLOW)  
 UNIT PKG.-25

**2577**

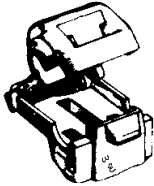

**FEMALE  
 SELF-STRIPPING T-TAP**  
 #16-14 WIRE (BLUE)  
 (MATES WITH W&E #2576)  
 UNIT PKG.-20

**3136**

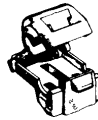

**FEMALE SELF STRIPPING  
 T-TAP**  
 #22-18 WIRE (RED)  
 MATES WITH W&E # 3141  
 UNIT PKG.-20

**3137**

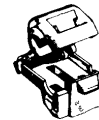

**FEMALE SELF STRIPPING  
 T-TAP**  
 #12-10 WIRE (YELLOW)  
 MATES WITH W&E # 3143  
 UNIT PKG.-20

**454**



**FULLY INSULATED FEMALE  
 QUICK DISCONNECT**  
 #16-14 WIRE (BLUE)  
 (USE WITH W&E #446 OR #2576)  
 UNIT PKG.-25

**2576**



**FULLY INSULATED  
 MALE SOLDERLESS TERMINALS**  
 #16-14 WIRE (BLUE)  
 (MATES WITH W&E #2577 & #454)  
 UNIT PKG.-25

**3140**

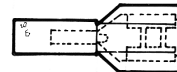

**FULLY INSULATED FEMALE  
 QUICK DISCONNECT  
 TERMINAL**  
 #22-18 WIRE (RED)  
 UNIT PKG.-25

**3141**

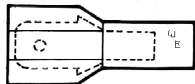

**FULLY INSULATED MALE  
 QUICK DISCONNECT  
 TERMINAL**  
 #22-18 WIRE (RED)  
 UNIT PKG.-25

**3142**

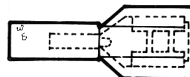

**FULLY INSULATED FEMALE  
 QUICK DISCONNECT  
 TERMINAL**  
 #12-10 WIRE (YELLOW)  
 UNIT PKG.-25

**3143**

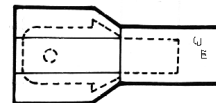

**FULLY INSULATED MALE  
 QUICK DISCONNECT  
 TERMINAL**  
 #12-10 WIRE (YELLOW)  
 UNIT PKG.-25

## ELECTRICAL CONNECTORS, HEAT SHRINKABLE TUBING

**453**



**DOUBLE RECEPTACLE  
SNAP PLUG  
#16-14 WIRE  
QUICK DISCONNECT  
(MATES WITH W&E #449)  
UNIT PKG.-25**

**QUICK DISCONNECTS  
#12-10 GAUGE WIRE  
COLOR-YELLOW**



**PART #  
452-FEMALE  
451-MALE  
EACH NUMBER UNIT PKG.-50**

**QUICK DISCONNECTS  
#22-18 GAUGE WIRE  
COLOR-RED**



**PART #  
2595-FEMALE  
2596-MALE  
EACH NUMBER UNIT PKG.-50**

**3138**

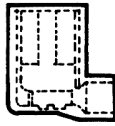

**FULLY INSULATED FLAG  
FEMALE QUICK DISCONNECT TERMINALS  
#22-16 WIRE (RED)  
UNIT PKG.-25**

**3139**

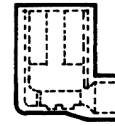

**FULLY INSULATED FLAG  
FEMALE QUICK DISCONNECT TERMINALS  
#16-14 WIRE (BLUE)  
UNIT PKG.-25**

## HEAT SHRINKABLE TUBING

HEAVY DUTY, DUAL WALL  
APPROX. 3:1 SHRINK RATIO  
INSULATES, SEALS AND PROTECTS WIRES AND SPLICES

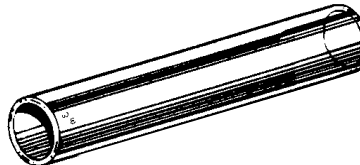

<u>PART #</u>	<u>LENGTH</u>	<u>COLOR</u>	<u>PRESHRINK I.D. (FRAC.)</u>	<u>POSTSHRINK I.D.</u>	<u>WIRE GAUGE</u>	<u>UNIT PKG.</u>
2667	12"	BLACK	.125" (1/8")	.023"	22-16	4
2668	12"	BLACK	.187" (3/16")	.060"	16-14	4
2669	12"	BLACK	.250" (1/4")	.080"	12-10	4
2670	6"	BLACK	.375" (3/8")	.118"	14-6	4
2671	6"	BLACK	.750" (3/4")	.311"	8-1	4
2672	6"	RED	.750" (3/4")	.311"	8-1	4
2673	6"	BLACK	1.00" (1")	.394"	2-4/10	4
2674	6"	RED	1.00" (1")	.394"	2-4/10	4



# HEAT SHRINK TERMINALS

**DESIGNED FOR WATERTIGHT, SEALED, SOLDERLESS ELECTRICAL CONNECTIONS**

**EASY TO USE:**

**INSERT STRIPPED WIRES, CRIMP, AND APPLY HEAT TO SHRINK TUBING.**

## BUTT CONNECTORS



<u>PART #</u>	<u>WIRE SIZE</u>	<u>COLOR</u>
2811	22-18	RED
2812	16-14	BLUE
2813	12-10	YELLOW

EACH UNIT PKG.-10

## RING TERMINALS



<u>PART #</u>	<u>WIRE SIZE</u>	<u>STUD SIZE</u>	<u>COLOR</u>
2822	22-18	#8	RED
2823	22-18	#10	RED
2824	16-14	#8	BLUE
2825	16-14	#10	BLUE
2826	16-14	1/4"	BLUE
2827	16-14	3/8"	BLUE
2828	12-10	#8	YELLOW
2829	12-10	#10	YELLOW
2830	12-10	1/4"	YELLOW
2831	12-10	3/8"	YELLOW
2832	12-10	1/2"	YELLOW

EACH UNIT PKG.-10

## FULLY INSULATED QUICK CONNECTS



<u>PART #</u>	<u>WIRE SIZE</u>	<u>COLOR</u>
2814 ( FEMALE)	22-18	RED
2815 ( MALE)	22-18	RED
2816 (FEMALE)	16-14	BLUE
2817 (MALE)	16-14	BLUE
2818 (FEMALE)	12-10	YELLOW
2819 (MALE)	12-10	YELLOW

EACH UNIT PKG.-10

## SPADE TERMINALS



<u>PART #</u>	<u>WIRE SIZE</u>	<u>STUD SIZE</u>	<u>COLOR</u>
2833	22-18	#10	RED
2834	16-14	#10	BLUE
2835	12-10	#10	YELLOW

EACH UNIT PKG.-10

## SNAP PLUGS



<u>PART #</u>	<u>WIRE SIZE</u>	<u>COLOR</u>
2820 (MALE)	16-14	BLUE
2821 (FEMALE)	16-14	BLUE

EACH UNIT PKG.-10

## HST-65



## HEAT SHRINK TERMINAL ASSORTMENT

PACKED IN A CLEAR POLYPROPYLENE BOX  
(11" WIDE, 6-3/4" DEEP AND 1-3/4" HIGH)

INCLUDES W&E #'S: 2811,2812,2813,2814,2815  
2816,2817,2818,2819,2820 & 2821

UNIT PKG.-1

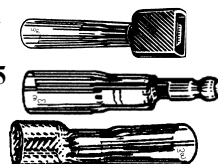

HST-65 HEAT SHRINK TERMINAL ASSORTMENT					
2811  HEAT SHRINK BUTT CONNECTOR 22-18 WIRE SIZE RED	2812  HEAT SHRINK BUTT CONNECTOR 16-14 WIRE SIZE BLUE	2812  HEAT SHRINK BUTT CONNECTOR 16-14 WIRE SIZE BLUE	2813  HEAT SHRINK BUTT CONNECTOR 12-10 WIRE SIZE YELLOW	2814  FULLY INSULATED QUICK CONNECT (FEMALE) 22-18 WIRE SIZE RED	2815  FULLY INSULATED QUICK CONNECT (MALE) 22-18 WIRE SIZE RED
2816  FULLY INSULATED QUICK CONNECT (FEMALE) 16-14 WIRE SIZE BLUE	2817  FULLY INSULATED QUICK CONNECT (MALE) 16-14 WIRE SIZE BLUE	2818  FULLY INSULATED QUICK CONNECT (FEMALE) 12-10 WIRE SIZE YELLOW	2819  FULLY INSULATED QUICK CONNECT (MALE) 12-10 WIRE SIZE YELLOW	2820  SNAP PLUG (MALE) 16-14 WIRE SIZE BLUE	2821  SNAP PLUG (FEMALE) 16-14 WIRE SIZE BLUE



## WIRE LOOM

SPLIT FLEXIBLE TUBING-HIGH TEMPERATURE NYLON

**PART #**

**SIZE**

2553	1/4" I.D.	3/8" O.D.
2554	3/8" I.D.	9/16" O.D.
2555	1/2" I.D.	11/16" O.D.
2556	3/4" I.D.	15/16" O.D.



EACH UNIT PKG.-10 FT.

## FUSES AND FUSE HOLDERS

**2862**

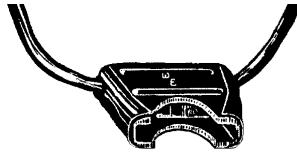

**FUSE HOLDER-ATO/ATC FUSES ACCOMMODATES:  
3 AMP TO 30 AMP  
12 GAUGE WIRE  
UNIT PKG.-1**

**2909**

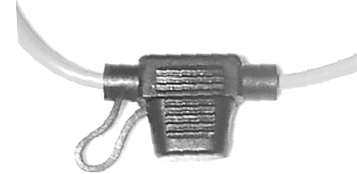

**FUSE HOLDER-MINI FUSES  
ACCOMMODATES:  
2 AMP TO 30 AMP  
12 GAUGE WIRE  
UNIT PKG.-1**

### MINI FUSES-(ATM)

<u>PART #</u>	<u>AMP</u>	<u>COLOR</u>
2689	2	GRAY
2690	3	PURPLE
2691	4	PINK
2692	5	TAN
2693	7.5	BROWN
2694	10	RED
2695	15	BLUE
2696	20	YELLOW
2697	25	WHITE
2698	30	GREEN

EACH UNIT PKG.-10

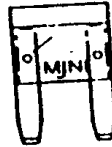

### LOW PROFILE MINI FUSES (LATE MODEL TOYOTA)

<u>PART #</u>	<u>AMP</u>	<u>COLOR</u>
3122	5	TAN
3123	7.5	BROWN
3124	10	RED
3125	15	BLUE
3126	20	YELLOW
3127	25	NATURAL
3128	30	GREEN

EACH UNIT PKG.-5



### AGC (GLASS ) FUSES

<u>PART #</u>	<u>AMP</u>
2868	1
2869	2
2870	3
2871	4
2872	5
2873	7.5
2874	10
2875	15
2876	20
2877	25
2878	30

EACH UNIT PKG.-10



### MAXI FUSES-

<u>PART #</u>	<u>AMP</u>	<u>COLOR</u>
2914	20	YELLOW
2915	30	GREEN
2916	40	ORANGE
2917	50	RED
2918	60	BLUE

EACH UNIT PKG.-2

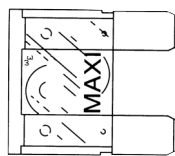

### AUTO FUSES- (ATO/ ATC)

<u>PART #</u>	<u>AMP</u>	<u>COLOR</u>	<u>UNIT PKG.</u>
2540	5	TAN	5
2808	7.5	BROWN	5
2541	10	RED	5
2542	15	BLUE	5
2543	20	YELLOW	5
2544	25	WHITE	5
2545	30	GREEN	5

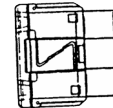

## AUTOMOTIVE BULBS (PICTURES NOT ACTUAL SIZE)

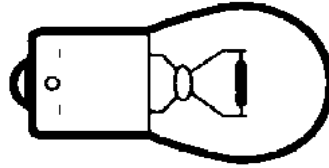
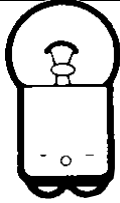

TYPE 1

TYPE 2

TYPE 3

TYPE 4

TYPE 5

TYPE 6

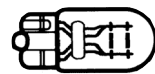
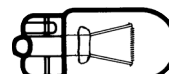
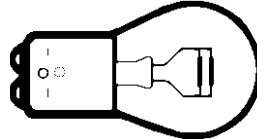
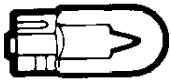

TYPE 7

TYPE 8

TYPE 9

TYPE 10

TYPE 11

TYPE 12

<u>PART #</u>	<u>TYPE</u>	<u>DESCRIPTION</u>
T-24	1	COURTESY
T-24NA	1	SIDE MARKER- GM
37	1	INSTRUMENT, INDICATOR, STEP/COURTESY-CHRYSLER, DODGE, FORD, GM, GMC, HYUNDAI, JEEP, LINCOLN, MAZDA, MERCURY, MITSUBISHI, SUBARU, SUZUKI, TOYOTA
53	2	INSTRUMENT, INDICATOR, STEP/COURTESY-ACURA, CHRYSLER, DODGE, JEEP, MITSUBISHI, SAAB
57	2	INSTRUMENT PANEL
67	2	PARK, TAIL, LICENSE PLATE
73	1	INSTRUMENT, STEP/COURTESY-DODGE, GM, GMC, INFINITI, MITSUBISHI, SATURN
74	1	INSTRUMENT PANEL
89	2	INSTRUMENT PANEL
90	3	DOVE, UNDER HOOD, INDICATOR, STEP/COURTESY-CHRYSLER, DODGE, GM, JEEP
93	4	UNDER HOOD, TRUNK-GM, GMC, ISUZU
97	2	COURTESY, DOVE, LICENSE PLATE-FORD AND IMPORTS
158	7	MARKER, DOVE, TRUNK, INSTRUMENT, STEP/COURTESY-CHRYSLER, DODGE, GM, HONDA, HYUNDAI, INFINITI, JEEP, MAZDA, MITSUBISHI, NISSAN, SUBARU, TOYOTA
T-161	10	MARKER, INSTRUMENT, INDICATOR, STEP/COURTESY-CHRYSLER, DODGE, GM, GMC, FORD, INFINITI, JEEP, LINCOLN, MERCURY, NISSAN, RENAULT, SATURN
168	7	SIDE MARKER, STOP-GM, FORD, CHRYSLER, HONDA AND TOYOTA
194	6	SIDE MARKER, INSTRUMENT, LICENSE PLATE
194NA	6	AMBER MARKER, INSTRUMENT, LICENSE PLATE
199	4	TURN, BACK-UP- MEDIUM AND HEAVY DUTY TRUCKS
904	6	MARKER, STEP/COURTESY-DODGE, FORD, MERCURY
906	6	HIGH MOUNT STOP
906NA	6	DOVE
912	6	INTERIOR, DOVE
912NA	6	INTERIOR, DOVE
T-916	6	TAIL LIGHTS- CHRYSLER, FORD
916NA	6	SIDE MARKER- FORD/MERCURY, WINSTAR, EXPLORER, LINCOLN, MUSTANG
T-921	6	STOP AND BACKUP- US AND IMPORTS
921NA	6	STOP AND BACKUP- US AND IMPORTS
T-922	6	BACK-UP, THIRD BRAKE LIGHT-CHRYSLER, DODGE, FORD
1003	4	COURTESY, DOVE, TRUNK- CHRYSLER AND GM
1004	9	DOVE, STEP/COURTESY-CHRYSLER, GM
T-1034	9	PARK, TURN SIGNAL-OLDER US MODELS, ISUZU-'94 & UP

EACH UNIT PKG.-10

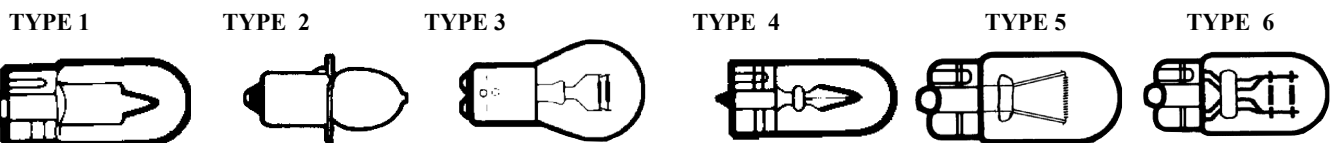
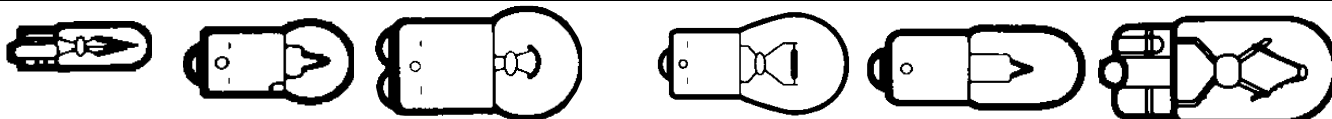

## AUTOMOTIVE BULBS (PICTURES NOT ACTUAL SIZE)



<u>PART #</u>	<u>TYPE</u>	<u>DESCRIPTION</u>
T-1073	4	SIGNAL, BACK-UP, PARKING, FOG-ISUZU, TOYOTA
T-2357	9	SIGNAL, PARKING
1141	4	BACKUP
1142	9	TRUNK, STEP/COURTESY-GM, GMC
1156	4	SIGNAL, TAIL, STOP AND PARKING
1156NA	4	SIGNAL, TAIL, STOP
1157	9	SIGNAL, TAIL, STOP AND PARKING
1157N	9	(NICKEL BASE) (REPLACES 7528, 12499, 17916) STOP, TAIL, MARKER
1157NA	9	AMBER SIGNAL, PARKING
1295	4	TURN SIGNAL- JEEP
1295NA	4	TURN SIGNAL- JEEP GRAND CHEROKEE
1445	2	SIDE MARKER- TRUCKS
1816	5	INSTRUMENT, INDICATOR-GM, FORD, MERCURY
1891	5	INTERIOR
1893	5	DOMES, INSTRUMENT PANEL-GM & FORD
1895	2	INSTRUMENT, GLOVE BOX-GM & FORD
2057	9	SIGNAL, TAIL, STOP & PARKING
2057NA	9	AMBER SIGNAL, PARKING
2357NA	9	AMBER SIGNAL, PARKING
3496	9	TAIL, STOP, MARKER & SIGNAL- HONDA, FORD PROBE
3497	9	DIRECTIONAL, STOP- HONDA & FORD PROBE
7440	11	TURN SIGNAL, BACKUP-ACURA, HONDA, ISUZU, LEXUS, SAAB-'96 & UP
7441	11	BACK UP-GM AVALANCHE, SUBURBAN, TAHOE, YUKON, ESCALADE
7443	12	TAIL, STOP LIGHT, ACURA, HONDA, ISUZU, LEXUS, SAAB- '96 & UP, SUBARU
7440NA	11	( NATURAL AMBER) TURN SIGNAL, BACK-UP-ACURA, HONDA, LEXUS
7443NA	12	( NATURAL AMBER) TAIL, STOP-ACURA, HONDA, LEXUS
12023	2	DOMES, MAP, STEP/COURTESY-AUDI, JAGUAR, SAAB, VOLVO, VW
12961	6	SIGNAL, MARKER, TAIL, LICENSE PLATE-TOYOTA, HONDA, VW, VOLVO,LEXUS, BMW SAAB, JAGUAR, PORSCHE
12498	4	CORNERING, BACK-UP, SIGNAL, STOP, HI-MOUNT STOP-EUROPEAN CARS
12516	10	INSTRUMENT- BMW, JAGUAR, MERCEDES, VOLVO
12594	9	TAIL, STOP, PARKING, MARKER-BMW, MERCEDES, SAAB,PORSCHE
12814	5	TAIL, MARKER, PARK, LICENSE PLATE--AUDI, PORSCHE, MERCEDES, VW
12821	5	TAIL, MARKER, SIGNAL, PARKING, LICENSE PLATE-EUROPEAN CARS
17638NA	4	TURN SIGNAL- PORSCHE, VOLVO
17640	4	OFFSET TABS, NICKEL BASE-BMW AND OTHER EUROPEAN CARS
PR-2	8	FLASH LIGHT- 2 CELL
PR-12	8	FLASH LIGHT- 5 CELL

EACH UNIT PKG.-10

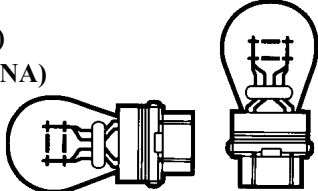
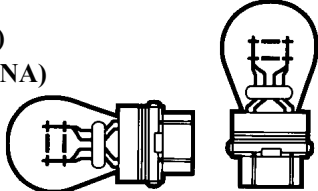
## AUTOMOTIVE BULBS (PICTURES NOT ACTUAL SIZE)

<u>W&amp;E Part #</u>	<u>Description</u>	
3057	SIGNAL, TAIL, STOP, BACKUP (REPLACES 2457 & 2458)	
3057NA	AMBER SIGNAL, PARKING (REPLACES 2457NA & 2458NA)	
3155	HIGH MOUNT STOP- GM-'96 & UP	
3156	BACKUP	
3156NA	AMBER PARKING, TURN SIGNAL- FORD	
3157	SIDE MARKER, SIGNAL, STOP, TAIL (REPLACES 2458 & 2459)	
3157NA	AMBER PARKING, TURN SIGNAL, SIDE MARKER (REPLACES 2458NA & 2459NA)	
3357	PARKING, TURN SIGNAL, MARKER & TAIL LAMP- GM & FORD	
3357NA	AMBER PARKING, TURN SIGNAL, MARKER & TAIL LAMP- GM & FORD	
3457	PARKING, TURN SIGNAL, MARKER & TAIL LAMP- GM & FORD	
3457NA	AMBER PARKING, TURN SIGNAL, MARKER & TAIL LAMP- GM & FORD	
3757NA	AMBER SIGNAL, PARKING, DAYTIME RUNNING LIGHTS-GM	
4057K	TURN SIGNAL, TAIL, STOP-FORD 2006 & UP	
4114K	DAYTIME RUNNING LIGHTS-GM TRUCKS-2002 & UP	
4157K (WILL REPLACE 3157K)	DAYTIME RUNNING LIGHTS-GM 2000 & UP, NISSAN-PARK & TURN	
4157NAK	AMBER PARKING, TURN, FRONT MARKER-GM, CHRYSLER, TOYOTA EACH UNIT PKG.-10	

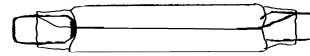
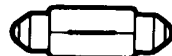
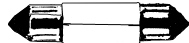







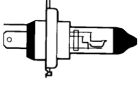
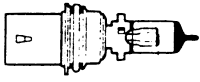
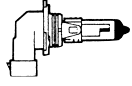
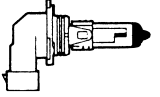

<u>W&amp;E Part #</u>	<u>Description</u>
272	INTERIOR/DOME (REPLACES DE-3022 & 13050)-MAZDA, TOYOTA, NISSAN, HONDA, VOLVO
317	INTERIOR/DOME (REPLACES DE-3175 & 12100)-MAZDA, TOYOTA, NISSAN, HONDA, VOLVO
211-2	DOME, COURTESY- AMC, GM, FORD, CHRYSLER
561	DOME, UNDER HOOD- GM -'77 & UP
12818	TRUNK, GLOVE, STEP, COURTESY (REPLACES DE-3021, 6428) IMPORTS
12844	TRUNK, GLOVE, STEP, COURTESY (REPLACES DE-3423, 6418, 11005) IMPORTS
12854	DOME, STEP, COURTESY, UNDER HOOD (REPLACES-DE-3425, 6461,11004)
12866	DOME, MAP, STEP/COURTESY, TRUNK, GLOVE-AUDI, BMW, CADILLAC, JAGUAR MERCEDES, PORSCHE, SAAB, VOLVO, VW EACH UNIT PKG.-10

### EUROPEAN/ JAPANESE INTERCHANGE

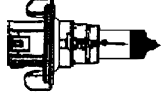
<u>W&amp;E #</u>	<u>WAGNER #</u>	<u>SYLVANIA #</u>	<u>PHILLIPS #</u>	<u>NARVA #</u>	<u>GE #</u>
272	13050	DE3022		17094	DE3022
317	12100	DE3175	DE3175	17315	DE3175
9003	9003	9003	9003	48881	
12023	47830	64111	12023	17830	
12498	17635	7506	12498	17635	P21W
12516	17037	2721	12516	17037	
12594	17881	7225	12594	17881	P21/4W
12814	17311	5008	12814	17311	R10W
12818	11006	6428	12818	17094	DE3021
12821	17171	5007	12821	17171	R5W
12844	11005	6418	12844	17125	DE3423
12854	11004	6461	12854	17316	DE3425
12866	17314	6411	12866	17314	
12961	17177	2825	12961	17177	W5W
1157N	17916	7528	12499	17916	P21/5W
17638NA	17638NA	7507	12496	17638	PY21W
H-7	H-7	64210	12972		

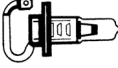
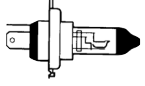
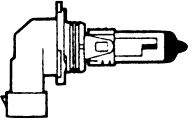
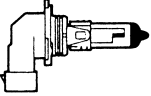
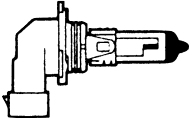
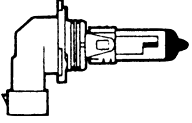
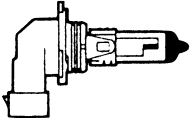
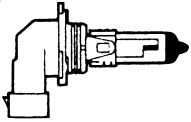

## HALOGEN BULBS (PICTURES NOT ACTUAL SIZE)

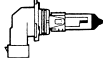
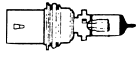
<p><b>9003</b></p>  <p><b>FOR MOST JAPANESE CARS UNIT PKG.-1</b></p>	<p><b>9004</b></p>  <p><b>DUAL BEAM HEAD LAMP UNIT PKG.-1</b></p>	<p><b>9005</b></p>  <p><b>HIGH BEAM HEAD LAMP UNIT PKG.-1</b></p>	<p><b>9006 (HB4)</b></p>  <p><b>LOW BEAM HEAD LAMP UNIT PKG.-1</b></p>	
<p><b>9007</b></p>  <p><b>DUAL BEAM HEADLAMP FORD &amp; CHRYSLER UNIT PKG.-1</b></p>	<p><b>H-13 (9008)</b></p>  <p><b>DUAL BEAM HEAD LAMP FORD F-150, DODGE DURANGO, FORD MUSTANG, NISSAN SENTRA 2004 &amp; UP UNIT PKG.-1</b></p>	 <p><b>9005SX-HIGH BEAM HEAD LAMP</b></p>  <p><b>9006SX-LOW BEAM HEAD LAMP CHRYSLER MINIVANS UNIT PKG.-1</b></p>		
<p><b>H-1</b></p>  <p><b>HALOGEN LAMP- ACURA, AUDI, BMW, HONDA, HYUNDAI, INFINITY, JAGUAR, MERCEDES, KIA, NISSAN, PORSCHE, SUBARU, VW, VOLVO UNIT PKG.-1</b></p>	<p><b>H-3</b></p>  <p><b>HALOGEN FOG LAMP-ACURA, AUDI, BMW, GM, HONDA, CHRYSLER, GMC, HYUNDAI, INFINITY, JEEP, JAGUAR, LAND ROVER, LEXUS, MERCEDES, MAZDA, MITSUBISHI, NISSAN, SUBARU, TOYOTA, VW, VOLVO UNIT PKG.-1</b></p>		<p><b>H-7</b></p>  <p><b>HALOGEN LAMP VW, BMW, PORSCHE UNIT PKG.-1</b></p>	
<p><b>H-8</b></p>  <p><b>HALOGEN FOG LAMP (35 WATTS) BMW, MERCEDES UNIT PKG.-1</b></p>	<p><b>H-9</b></p>  <p><b>HALOGEN LAMP (65 WATTS) HEADLAMP AUDI, MAZDA, MINI COOPER, VW (SELECTED MODELS) UNIT PKG.-1</b></p>	<p><b>H-10 (9145)</b></p>  <p><b>HALOGEN FOG LAMP (45 WATTS) CADILLAC, TOYOTA, CHEVY &amp; FORD TRUCKS-2003 &amp; UP UNIT PKG.-1</b></p>	<p><b>H-11</b></p>  <p><b>HALOGEN HEADLAMP/FOG LAMP-(55 WATTS) ACURA, AUDI, CHEVY MALIBU, HONDA, LAND ROVER, LINCOLN, MAZDA, MINI COOPER, MITSUBISHI, NISSAN, PONTIAC, SATURN, TOYOTA, VW UNIT PKG.-1</b></p>	
<p><b>9011 (HIR1)</b></p>  <p><b>HALOGEN HEAD LAMP-HIGH BEAM (65 WATTS) CHEVY AVALANCHE INFINITY-2000 &amp; UP UNIT PKG.-1</b></p>	<p><b>H-12 (9055)</b></p>  <p><b>(ALSO KNOWN AS- 9055) AUTOMOTIVE BULB FOG LAMP JEEP 1997 &amp; UP UNIT PKG.-1</b></p>	<p><b>MHL-880</b></p>  <p><b>HALOGEN FOG LAMP GM &amp; UNIVERSAL UNIT PKG.-1</b></p>	<p><b>MHL-889</b></p>  <p><b>MINI HALOGEN RIGHT ANGLE HIGH MOUNT STOP UNIT PKG.-1</b></p>	<p><b>MHL-890</b></p>  <p><b>MINI HALOGEN SIGNAL, PARK, BACK UP UNIT PKG.-1</b></p>

## HALOGEN BULBS (PICTURES NOT ACTUAL SIZE)

**MHL-891**

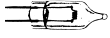

MINI HALOGEN  
HIGH MOUNT STOP  
UNIT PKG.-1

**MHL-899**



MINI HALOGEN LAMP  
DRIVING LIGHTS  
FORD  
UNIT PKG.-1

**2040**



HALOGEN LAMP  
CENTER GRILLE  
MERCURY SABLE-'86 & UP  
MERCURY VILLAGER-'96 & UP  
UNIT PKG.-1

## HIGH INTENSITY DISCHARGE (HID) LAMPS

**D2R**

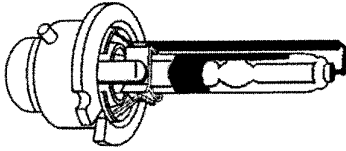

HIGH INTENSITY DISCHARGE (HID) LAMP  
(USE WITH REFLECTOR SYSTEMS)  
HEADLAMPS-  
ACURA, AUDI, INFINITI, LEXUS, LINCOLN,  
MERCEDES, MINI COOPER, NISSAN, TOYOTA  
VOLVO-2000 & UP (SELECTED MODELS)  
UNIT PKG.-1

**D2S**

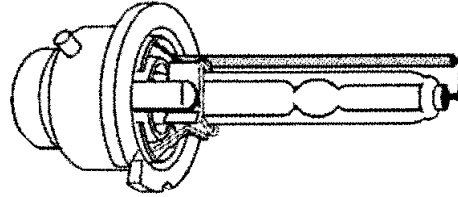







HIGH INTENSITY DISCHARGE (HID) LAMP  
(USE WITH PROJECTION SYSTEMS  
WITH LIGHT SHIELD)  
ACURA, AUDI, BMW, CHRYSLER, HONDA,  
INFINITI, JAGUAR, LEXUS, MAZDA,  
MERCEDES, MITSUBISHI, NISSAN, TOYOTA  
SAAB, VW-2000 & UP (SELECTED MODELS)  
UNIT PKG.-1

## DAYTIME RUNNING LIGHT APPLICATION GUIDE

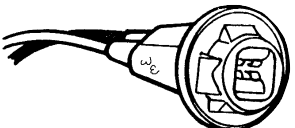
<u>MAKE/MODEL</u>	<u>YEAR</u>	<u>BULB</u>	<u>MAKE/MODEL</u>	<u>YEAR</u>	<u>BULB</u>
<u>ACURA NSX</u>	'98-'04	1156	<u>CHEVROLET:</u>		
<u>AM GENERAL:</u>			VENTURE	'00-'04	4157NA
HUMMER	'03-'04	4157K	VENTURE	'97-'99	3157NA
<u>AUDI:</u>			<u>CHRYSLER:</u>		
A4	'02-'04	12961	CIRRUS	'98-'00	3157NA
A4 AVANT	'02-'04	12961	PROWLER	2002	3157NA
A6	'02-'04	12961	<u>DODGE STRATUS</u>	'98-'00	3157NA
A6 AVANT	'02-'04	12961	<u>FORD FOCUS</u>	'02-'04	3157
RS6	'03-'04	12961	<u>GMC:</u>		
S4	'02-'04	12961	CANYON	2004	3757NA
S4 AVANT	2004	12961	DENALI/DENALI XL	'01-'04	4157K
S4 AVANT	2002	12961	SIERRA	'99-'04	4157K
S6 AVANT	'02-'04	12961	YUKON/YUKON XL	'00-'04	4157K
S8	'01-'02	12961	<u>MERCURY VILLAGER</u>	'00-'02	3157NA
<u>BUICK LESABRE</u>	'99-'04	3156	<u>NISSAN:</u>		
<u>CADILLAC:</u>			ALTIMA	'00-01	3457NA
ESCALADE	'02-'04	4157K	MAXIMA	2004	1156
SRX	2004	3757NA	QUEST	'00-'02	3157NA
XLR	2004	3757NA	<u>OLDS SILHOUETTE</u>	'97-'03	3157NA
<u>CHEVROLET:</u>			<u>PLYMOUTH BREEZE</u>	'98-'00	3157NA
AVALANCHE	'02-04	3457	<u>PONTIAC:</u>		
COLORADO	2004	3757NA	MONTANA	'99-'04	3157NA
SILVERADO PICK-UP	'99-'04	4157K	TRANS SPORT	'97-'98	3157NA
SUBURBAN	'00-'04	4157K	<u>TOYOTA 4RUNNER</u>	'03-'04	4157NAK
TAHOE	'00-'04	4157K	<u>VW PASSAT</u>	'98-'01	H-7

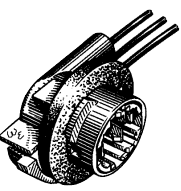

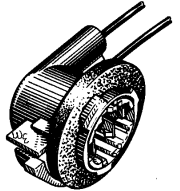
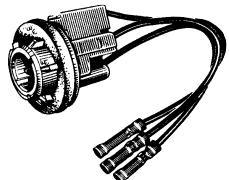
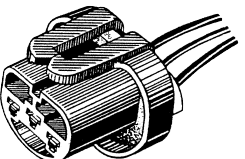
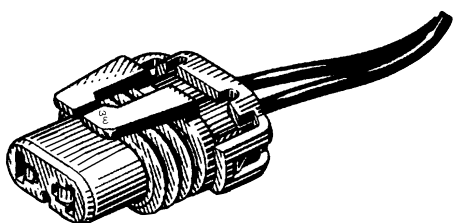
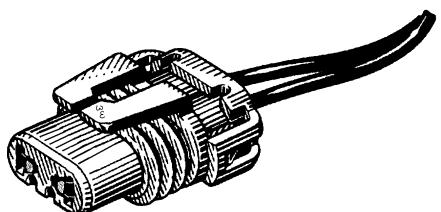
## BULB SOCKETS/ PIGTAIL CONNECTORS

<p><b>3029</b></p>  <p>(GM-6298935, 6294015, 8918527, 8901283)          (FORD-D7AZ-13412-A, D40Z-13410E, D7FZ-13412-A)  <b>SIDE MARKER LIGHT SOCKET</b>          USE-67, 158, 194 OR 194NA BULBS</p> <p style="text-align: center;">UNIT PKG.-2</p>	<p><b>3030</b></p>  <p>(12083005)  <b>SOCKET- DOUBLE CONTACT BULBS</b>          BACK-UP, PARK, STOP, TAIL, TURN          GM-'88-'98          USE-3057, 3157, 3057NA OR 3157NA BULBS</p> <p style="text-align: center;">UNIT PKG.-1</p>		
<p><b>3031</b></p>  <p>(12083680)  <b>SOCKET</b>          DOUBLE CONTACT BULBS          BACK-UP, PARK, STOP, TAIL,          TURN          GM-'88-'98          USE-3057, 3157          OR 3157NA BULBS</p> <p style="text-align: center;">UNIT PKG.-1</p>	<p><b>3032</b></p>  <p>(GM-12001470, 12116169,          12078178)          (FORD-EOSZ-15A442B)  <b>CORNER MARKER</b>  <b>SOCKET</b>          TAIL, STOP &amp; LICENSE          USE 158, 194          OR 194NA BULBS</p> <p style="text-align: center;">UNIT PKG.-1</p>	<p><b>3033</b></p>  <p>(12085330)  <b>SOCKET- BACK-UP,</b>          DRIVING, LICENSE          PLATES          GM-'88 &amp; UP          USE 3156 BULB</p> <p style="text-align: center;">UNIT PKG.-1</p>	<p><b>3034</b></p>  <p>(D4LY-13410-A)  <b>SOCKET-DOUBLE</b>          CONTACT BULBS          STOP, TAIL, TURN          7" WIRE LEAD WITH          BUTT SPLICES          FORD-'73-'98          USE 1157 BULB</p> <p style="text-align: center;">UNIT PKG.-1</p>
<p><b>2846</b></p>  <p>(GM-12048369)  <b>UNIVERSAL HEADLIGHT SOCKET</b>          (4 HEADLIGHT SYSTEM)FOR 9004 &amp; 9007 BULBS</p> <p style="text-align: center;">UNIT PKG.-2</p>	<p><b>2847</b></p>  <p><b>UNIVERSAL HEADLIGHT SOCKET</b>          FOR 9006 BULBS (LOW BEAM)</p> <p style="text-align: center;">UNIT PKG.-2</p>		
<p><b>2934</b></p>  <p><b>UNIVERSAL HEADLIGHT SOCKET</b>          FOR 9005 AND H-10 BULBS (HIGH BEAM)</p> <p style="text-align: center;">UNIT PKG.-2</p>	<p><b>3283</b></p>  <p><b>HEADLIGHT SOCKET</b>          FOR H-13 BULB          (SAME AS 9008 BULB)          FORD, NISSAN</p> <p style="text-align: center;">UNIT PKG.- 1</p>		



## BULB SOCKETS/ PIGTAIL CONNECTORS

**3195**

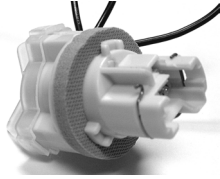

(E8PZ-13411A)  
SOCKET  
TURN SIGNAL, STOP, TAIL, PARK & MARKER  
3157 BULB-FORD  
UNIT PKG.-2

**3196**

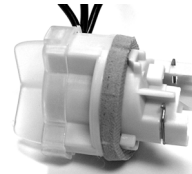

(E8PZ-13411B)  
SOCKET  
TURN SIGNAL, STOP, TAIL, PARK & MARKER  
3157 BULB-FORD  
UNIT PKG.-2

**3197**

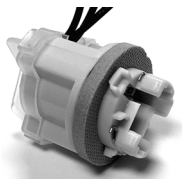

(E8PZ-13411C)  
SOCKET-TURN SIGNAL, STOP, TAIL, PARK &  
MARKER, 3157 BULB-FORD  
UNIT PKG.-2

**3198**

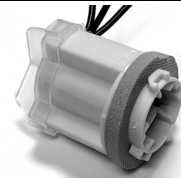

(E8PZ-13411D)  
SOCKET  
TURN SIGNAL, STOP, TAIL, PARK & MARKER  
3157 BULB-FORD  
UNIT PKG.-2

**3199**

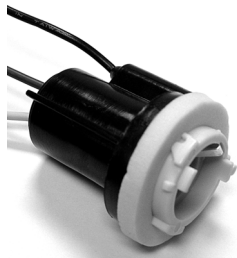

(GM-12013813, 8919916)  
SOCKET-DOUBLE CONTACT  
STOP & TAIL  
1157 BULB  
UNIT PKG.-2

**3200**

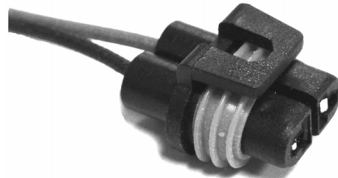

SOCKET  
FOR H8, H9 AND H11 BULBS  
UNIT PKG.-1

**3227**

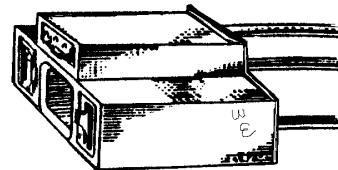

SOCKET-  
FOR 9003 (H4) BULBS  
UNIT PKG.-2

**3201**

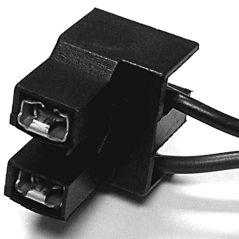

SOCKET  
FOR H7 BULB  
UNIT PKG.-2

**3213**

(D3AZ-13410-D)  
(D4SZ-13410-E)  
(D4OZ-13410-D)  
FORD PIGTAIL  
DOUBLE CONTACT  
SOCKET - SIGNAL,  
STOP & TAIL LIGHT  
UNIT PKG.-2



**3324**

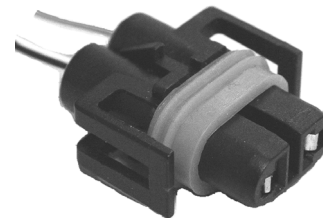

SOCKET  
FOR H8 AND H11 BULBS  
UNIT PKG.-1

## SHIMS-PLATED

### UNIVERSAL BALL JOINT & CASTER & CAMBER SHIMS-PLATED

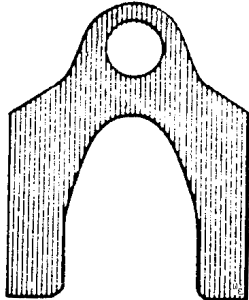

1-1/2" X 1-3/16"  
5/8" MAXIMUM SLOT

<u>PART #</u>	<u>THICKNESS</u>
973	1/32"
974	1/16"
975	1/8"

EACH UNIT PKG.-50

### C TYPE BODY SHIMS



15/16" O.D., 3/8" SLOT

<u>PART #</u>	<u>THICKNESS</u>
3144	1/16"
3145	1/8"

EACH UNIT PKG.-50

## COWL-HOOD-FENDER SHIMS-PLATED

965

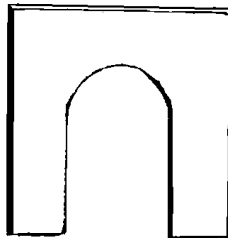

1-1/16" X 1-1/4"  
1/16" THICK- 1/2" SLOT

UNIT PKG.-50

966

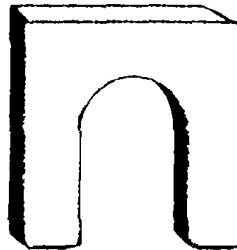

1-1/4" X 1-1/8"  
1/8" THICK- 3/8" SLOT

UNIT PKG.-50

969

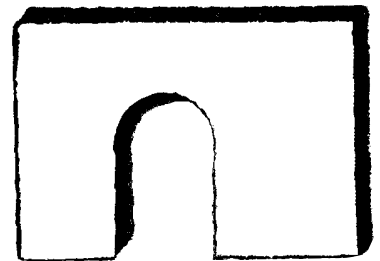

1-3/4" X 1-1/4"  
1/8" THICK- 1/2" SLOT  
UNIT PKG.-50

970

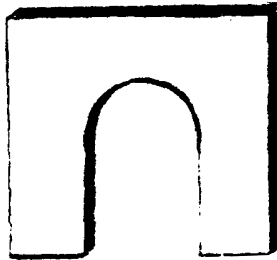

1-3/8" X 1-1/4"  
1/16" THICK- 5/8" SLOT  
UNIT PKG.-50

971

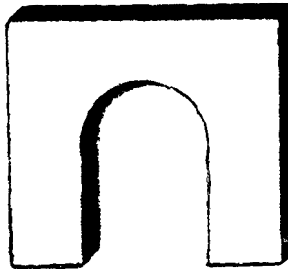

1-3/8" X 1-1/4"  
1/8" THICK- 5/8" SLOT  
UNIT PKG.-50

972

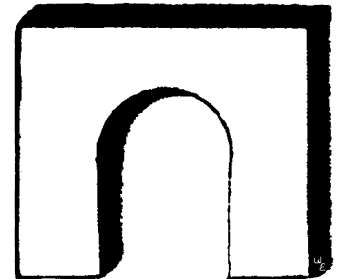

1-3/8" X 1-1/4"  
3/16" THICK- 5/8" SLOT  
UNIT PKG.-25

2448

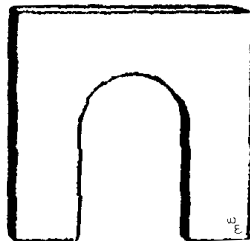

1-1/4" X 1-1/8"  
1/16" THICK- 3/8" SLOT  
UNIT PKG.-50

2449

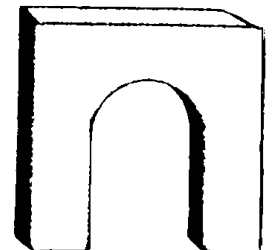

1-1/8" X 1-1/4"  
1/8" THICK- 1/2" SLOT  
UNIT PKG.-50

**METRIC HEX HEAD CAP SCREWS**

**USS HEX HEAD CAP SCREWS**

**DIN 933 ZINC PLATED**

**GRADE 5 ZINC PLATED**

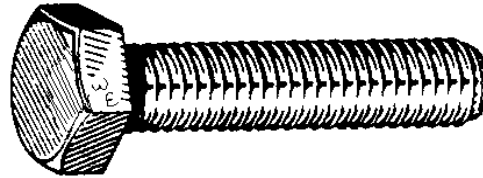
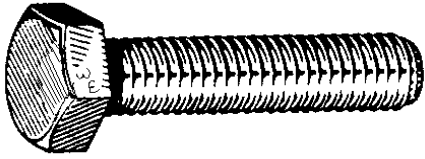

<u>W&amp;E #</u>	<u>SIZE</u>	<u>UNIT PKG.</u>
5401	4 X 16 MM	25
5402	4 X 20 MM	25
5501	5 X 16 MM	25
5502	5 X 20 MM	25
5601	6 X 16 MM	25
5602	6 X 20 MM	25
5603	6 X 25 MM	25
5604	6 X 30 MM	25
5606	6 X 40 MM	25
5608	6 X 50 MM	25
5801	8 X 16 MM	25
5802	8 X 20 MM	25
5803	8 X 25 MM	25
5804	8 X 30 MM	25
5805	8 X 35 MM	25
5806	8 X 40 MM	25
5808	8 X 50 MM	15
5810	8 X 60 MM	15
5102	10 X 20 MM	15
5103	10 X 25 MM	15
5104	10 X 30 MM	15
5106	10 X 40 MM	15
5108	10 X 50 MM	15
5110	10 X 60 MM	15
5124	12 X 30 MM	10
5126	12 X 40 MM	10

<u>W&amp;E #</u>	<u>SIZE</u>	<u>UNIT PKG.</u>
4101	1/4 X 1/2"	100
4102	1/4 X 3/4"	100
4103	1/4 X 1"	100
4104	1/4 X 1-1/4"	100
4105	1/4 X 1-1/2"	50
4107	1/4 X 2"	50
4112	5/16 X 3/4"	50
4113	5/16 X 1"	50
4114	5/16 X 1-1/4"	50
4115	5/16 X 1-1/2"	50
4117	5/16 X 2"	50
4119	5/16 X 2-1/2"	50
4122	3/8 X 3/4"	50
4123	3/8 X 1"	50
4124	3/8 X 1-1/4"	50
4125	3/8 X 1-1/2"	50
4126	3/8 X 1-3/4"	25
4127	3/8 X 2"	50
4129	3/8 X 2-1/2"	25
4133	7/16 X 1"	50
4135	7/16 X 1-1/2"	25
4137	7/16 X 2"	25
4145	1/2 X 1-1/2"	25
4147	1/2 X 2"	25
4149	1/2 X 2-1/2"	15

**METRIC NUTS- ZINC PLATED  
DIN 934**

**USS NUTS- ZINC PLATED**

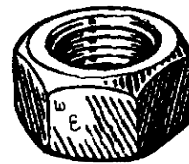
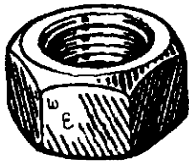

<u>W&amp;E #</u>	<u>SIZE</u>	<u>UNIT PKG.</u>
5004	4 X .7 MM	100
5005	5 X .8 MM	100
5006	6 X 1 MM	100
5008	8 X 1.25 MM	100
5010	10 X 1.5 MM	50
5012	12 X 1.75 MM	25

<u>W&amp;E #</u>	<u>SIZE</u>	<u>UNIT PKG.</u>
4001	1/4"-20	100
4002	5/16"-18	100
4003	3/8"-16	100
4004	7/16"-14	100
4005	1/2"-13	50



## GRADE 8 HEX HEAD CAP SCREWS & NUTS USS ZINC PLATED

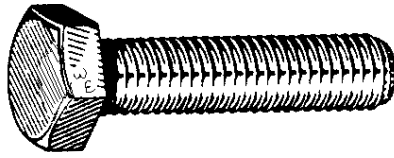

<u>W&amp;E #</u>	<u>SIZE</u>	<u>UNIT PKG.</u>
2531	1/2-13 X 2-1/2"	10
2532	1/2-13 X 3"	10
2533	5/8-11 X 2"	10
2434	5/8-11 X 3"	5
2435	5/8-11 X 3-1/2"	5

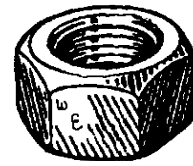

<u>W&amp;E #</u>	<u>SIZE</u>	<u>UNIT PKG.</u>
2530	1/2"-13	25
2436	5/8"-11	10

### HIGH STRENGTH USS FLAT WASHERS ZINC/YELLOW PLATED



<u>W&amp;E #</u>	<u>SIZE</u>	<u>O.D.</u>	<u>UNIT PKG.</u>
2593	1/2"	1-3/8"	25
2594	5/8"	1-3/4"	15

### FENDER WASHERS FLAT TYPE-ZINC PLATED

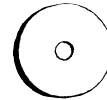

<u>W&amp;E #</u>	<u>SIZE</u>
951	1/4" X 1-1/4"
952	5/16" X 1-1/4"
953	5/16" X 1-1/2"
957	3/8" X 1-1/2"

EACH UNIT PKG.- 50

### SAE FLAT WASHERS- ZINC



<u>W&amp;E #</u>	<u>SIZE</u>	<u>UNIT PKG.</u>
2601	1/4"	100
2602	5/16"	100
2603	3/8"	100
2604	7/16"	100
2605	1/2"	50

### USS FLAT WASHERS- ZINC



<u>W&amp;E #</u>	<u>SIZE</u>
4200	3/16"
4201	1/4"
4202	5/16"
4203	3/8"
4204	7/16"
4205	1/2"

EACH UNIT PKG.- 1 LB.

### METRIC FLAT WASHERS- ZINC



<u>W&amp;E #</u>	<u>SIZE</u>
5970	4 MM
5971	5 MM
5949	6 MM
5950	8 MM
5951	10 MM
3222	12 MM

EACH UNIT PKG.- 100

### SPRING TYPE LOCK WASHERS- ZINC PLATED

<u>W&amp;E #</u>	<u>SIZE</u>	<u>W&amp;E #</u>	<u>SIZE</u>
4210	3/16"	5972	4 MM
4211	1/4"	5973	5 MM
4212	5/16"	5956	6 MM
4213	3/8"	5957	8 MM
4214	7/16"	5958	10 MM
4215	1/2"	3223	12 MM



EACH UNIT PKG.- 100

**HIGH SPEED PANEL "PUNCH" TWIST DRILLS  
HIGHEST QUALITY—US MADE— BRIGHT  
APPROX.— 2" OVERALL LENGTH, NON WALKING SPLIT POINT**

**DOUBLE END DRILLS**



<u>PART #</u>	<u>DECIMAL SIZE</u>	<u>FRACTIONAL EQUIV.</u>	<u>UNIT PKG.</u>
<b>BPX-1/8</b>	.125	1/8"	12
<b>BPX-30</b>	.1285	1/8"	6
<b>BPX-11</b>	.191	3/16"	6
<b>BPX-1/4</b>	.253	1/4"	6

**SINGLE END DRILLS  
IN RE-USABLE PLASTIC BAG**



<u>PART #</u>	<u>DECIMAL SIZE</u>	<u>FRACTIONAL EQUIV.</u>	<u>PCS. PER BAG</u>
<b>BPD-7/64</b>	.1094	7/64"	12
<b>BPD-1/8</b>	.125	1/8"	12

**HIGH SPEED COBALT SPOT WELD DRILLS  
IMPROVED DESIGN- MADE IN USA -OVERALL LENGTH-2.25"**

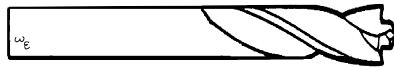

<u>PART #</u>	<u>SIZE</u>	<u>UNIT PKG.</u>
<b>SWD-8</b>	8 MM DIAM. DRILL FOR 5/16" SPOT WELD	5
<b>SWD-10</b>	10 MM DIAM. DRILL FOR 3/8" SPOT WELD	5

**SPOT WELD DRILL BITS  
FOR NEW ULTRA HIGH STRENGTH STEEL (BORON)  
USED MAINLY FOR EUROPEAN VEHICLES**



<u>PART #</u>	<u>SIZE</u>
<b>BSWD-14 (2 FLUTE)</b>	1/4"
<b>BSWD-83 (3 FLUTE)</b>	5/16"



MADE IN USA  
EACH UNIT PKG.— 1

## HIGH SPEED TWIST DRILLS IN SETS JOBBER LENGTH DRILLS IN DRILL INDEX

**HIGH QUALITY  
US MADE**

**135 DEGREE SPLIT POINT  
BRIGHT FINISH**

**DS-13 & DI-3**



**DS-15 & DI-5**



**DS-29 & DI-9**



**DS-13— 13 SIZES H.S. JOBBER LENGTH DRILLS: 1/16"–1/4" BY 64ths**

**DS-15— 15 SIZES H.S. JOBBER LENGTH DRILLS: 1/16"–1/2" BY 32nds**

**DS-29— 29 SIZES H.S. JOBBER LENGTH DRILLS: 1/16"–1/2" BY 64ths**

### DRILL INDEX ONLY— WITHOUT DRILLS

**DI-3— 13 SIZES H.S. JOBBER LENGTH DRILLS: 1/16"–1/4" BY 64ths**

**DI-5— 15 SIZES H.S. JOBBER LENGTH DRILLS: 1/16"–1/2" BY 32nds**

**DI-9— 29 SIZES H.S. JOBBER LENGTH DRILLS: 1/16"–1/2" BY 64ths**

**ALL UNIT PKG.-1**

## HIGH SPEED STEEL TWIST DRILLS 135 DEGREE SPLIT POINT-US MADE FRACTIONAL SIZES - JOBBER LENGTH - BRIGHT FINISH

<u>SIZE</u>	<u>LENGTH INCHES</u>	<u>UPKG.</u>	<u>SIZE</u>	<u>LENGTH INCHES</u>	<u>UPKG.</u>	<u>SIZE</u>	<u>LENGTH INCHES</u>	<u>UPKG.</u>
1/16	1-7/8	10	7/32	3-3/4	5	3/8	5	3
5/64	2	10	15/64	3-7/8	5	25/64	5-1/8	3
3/32	2-1/4	10	1/4	4	5	13/32	5-1/4	3
7/64	2-5/8	10	17/64	4-1/8	5	27/64	5-3/8	3
1/8	2-3/4	10	9/32	4-1/4	5	7/16	5-1/2	3
9/64	2-7/8	10	19/64	4-3/8	3	29/64	5-5/8	3
5/32	3-1/8	10	5/16	4-1/2	3	15/32	5-3/4	3
11/64	3-1/4	10	21/64	4-5/8	3	31/64	5-7/8	3
3/16	3-1/2	10	11/32	4-3/4	3	1/2	6	3
13/64	3-5/8	10	23/64	4-7/8	3			

## HOG RING PLIERS

HG-8



**(FOR USE WITH HOG RINGS- W&E PART #1220 PG. 60)**  
 FLAT ANGLED NOSE, EASIER ACCESSIBILITY, EXCELLENT FOR ALL INSTALLATIONS  
 INCLUDING NON-REMOVABLE CUSHIONS  
 UNIT PKG.-1

## PLASTIC BLIND RIVETING TOOL

NK-5

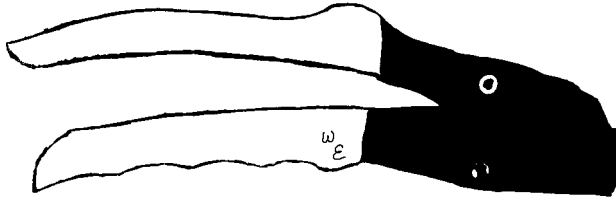

FOR USE WITH ALL W & E SALES CO. AND OTHER PLASTIC BLIND RIVETS  
 NO NEED TO CHANGE NOSEPIECE  
 FITS ALL SIZE PLASTIC MANDRELS  
 (SEE PG. 72 FOR W&E PLASTIC RIVETS)  
 UNIT PKG.-1

## HOSE CLAMPS

**WORM DRIVE-STAINLESS STEEL BAND  
 PLATED CARBON STEEL SCREW & HOUSING**

<u>PART</u>	<u>#SIZE</u>	<u>CLAMP RANGE</u>
2564	#4	7/32"- 5/8"
2565	#6	5/16"-7/8"
2566	#10	9/16"-1-1/16"
2567	#12	9/16"-1-1/4"
2568	#20	3/4"-1-3/4"
2569	#24	1-1/16"-2"
2570	#28	1-5/16"-2-1/4"
2754	#32	1-9/16"-2-1/2"
2571	#36	1-13/16"-2-3/4"

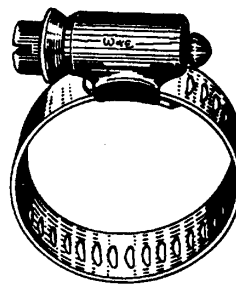

EACH NUMBER UNIT PKG.-10

## WINDSHIELD REMOVAL

**WK-3**

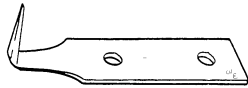

**WINDSHIELD REMOVAL BLADES  
USE WITH WOODEN HANDLE KNIFE  
UNIT PKG.-6**

**WK-10**

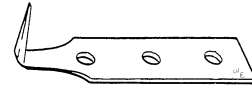

**WINDSHIELD KNIFE BLADES-LONG POINT  
THREE HOLE, SHARP 1" POINT  
FOR URETHANE BONDED WINDOWS  
FOR USE WITH CABLE PULL TYPE KNIFE  
UNIT PKG.-5**

**PW-15**

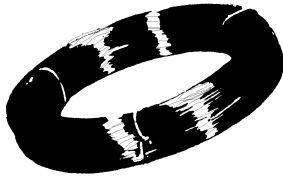

**PIANO WIRE  
FOR REMOVAL OF WINDSHIELDS NOT BROKEN  
1/4 LB. HANK  
UNIT PKG.-1**

**WW-72**



**THREE STRANDED "GOLD"  
WINDSHIELD WIRE  
FOR CUTTING URETHANE  
WINDSHIELD SEALS  
72 FT. COIL  
UNIT PKG.-1**

## DOOR AND TRUNK WEATHERSTRIP-EPDM / NEOPRENE

**17**

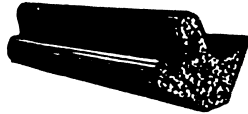

**FORD, LINCOLN, MERCURY,  
COMET, EDEL, CONTINENTAL  
UNIT PKG.-50 FT. ROLL**

**18**



**CHRYSLER, FORD, GM,  
VALIANT, STUDEBAKER, LARK  
WATER RUN-OFF WEATHERSTRIPPING  
UNIT PKG.-50 FT. ROLL**

**19**

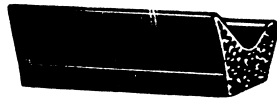

**CHRYSLER, GM, GMC, CHEVROLET TRUCKS,  
FALCON, JEEP AND RAMBLER  
UNIT PKG.-50 FT. ROLL**

**30**

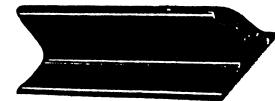

**ALL GM CARS  
UNIT PKG.-50 FT. ROLL**

**31**

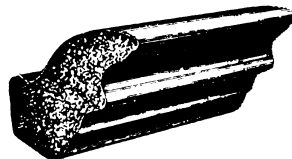

**DECK LID WEATHERSTRIP  
GM CARS  
UNIT PKG.-50 FT. ROLL**



**6000**

**ALL PURPOSE  
CLAMP BRACKET**



9" long x 1 3/4" wide 3/4" grab - steel angle

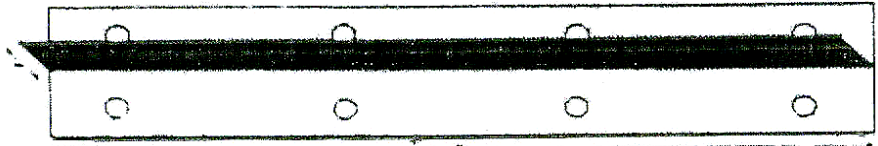

**Feature 1: TIE DOWN** - Especially useful where bodies do not have a pinch weld (Mercedes, etc.) or where pinch weld has been damaged..

**Feature 2: BODY AND FRAME STRAIGHTENING** - Especially useful on unitized bodies and areas where there are no places for clamps to grab. (front end, rear-end)

**Feature 3:** Part can be welded or bolted to areas to be straightened.

**Feature 4:** There is enough area on bracket so it can be used with all types of clamps.

UNIT PKG. - 6

**BRG-1**

MADE IN USA

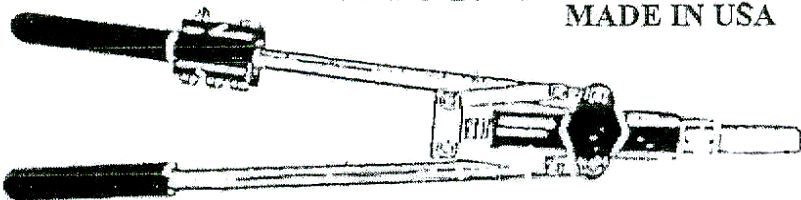

Includes eight nosepieces to install 3/32", 1/8", 5/32", 3/16", 1/4"; 3/16" & 1/4" monobolts; 1/4" window regulator rivets. See pgs. 89-92 for a complete selection of W&E rivets.

UNIT PKG.-1

**STECK PULL RODS PULL ROD SET - NO. PR 200**

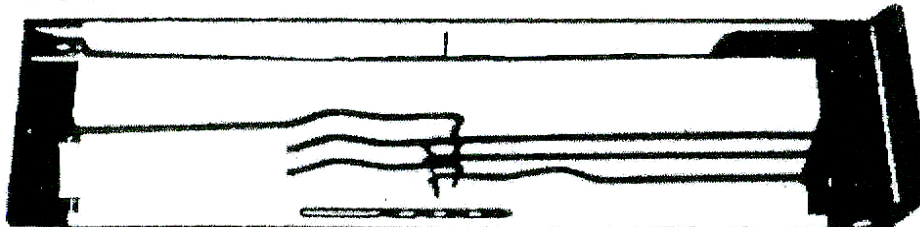

Pull Rods eliminate removal of upholstery and cutting out inner panels. With Pull Rods, you direct your time and effort to repairing the job, not trying to get at it!

You work exclusively outside the car. This method of body repair is fast.

DRILL HOLES - - PULL OUT DAMAGE - - FILL HOLES - - and you are ready to refinish.

SET INCLUDES: 4 PULL RODS, 2 PICK PULLS, STAINLESS STEEL STRAIGHT-EDGE, 3/16" DRILL.

UNIT PKG.- 1 SET

**PULL RODS**

**PR-200-1 PULL ROD**

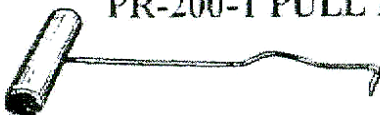

UNIT PKG.-1

PLEASE CONTACT US VIA PHONE, FAX  
OR EMAIL WITH ANY QUESTIONS



## "METRIC CONVERSION TABLE"

Millimeter/Decimal/Fractional Equivalents

METRIC	DEC.	FRACT.	METRIC	DEC.	FRACT.	METRIC	DEC.	FRACT.
0.3968mm	.0156"	1/64"	13mm	.5118"		29mm	1.1417"	
0.7924	.0312	1/32	14	.5512		30	1.1811	
1	.0394		14.2875	.5625	9/16"	35	1.3779	
1.5875	.0625	1/16	15	.5905		38.1	1.5000	1 1/2"
2	.0787		15.8750	.625	5/8	40	1.5748	
3	.1181		16	.6299		45	1.7716	
3.175	.1250	1/8	17	.6693		50	1.9685	
4	.1575		18	.7087		50.8	2.000	2
4.7625	.1875	3/16	19	.748		55	2.1653	
5	.1968		19.05	.750	3/4	60	2.3622	
6	.2362		20	.7874		63.5	2.500	2 1/2
6.35	.2500	1/4	21	.8268		65	2.5590	
7	.2756		22	.8661		70	2.7559	
7.9375	.3125	5/16	22.23	.875	7/8	75	2.9527	
8	.3150		23	.9055		76.2	3.000	3
9	.3543		24	.9449		80	3.1496	
9.525	.375	3/8	25	.9842		85	3.3464	
10	.3937		25.4	1.0000	1	90	3.5433	
11	.4331		26	1.0236		95	3.7041	
11.1125	.4375	7/16	27	1.0630		100	3.9370	
12	.4724		28	1.1024		101.6	4.000	4
12.7	.5000	1/2						

PLEASE CONTACT US VIA PHONE, FAX  
OR EMAIL WITH ANY QUESTIONS

VISIT OUR WEBSITE AT:

**WWW.WESALES.COM**

**RB-8**



PLASTIC RAZOR BLADE  
FOR USE ON PLASTIC COATED  
WINDSHIELDS OR ANYWHERE  
SCRATCHING BY A METAL BLADE  
MIGHT BE A PROBLEM

UNIT PKG. 10

**PT-217**

TRIM PAD REMOVING  
TOOL

Reaches under interior trim panels and lifts it without damaging the pad backboard -Long enough to reach the most recessed fastener and pries only against hidden surfaces to eliminate the danger of scratching the paint.

UNIT 1 EACH

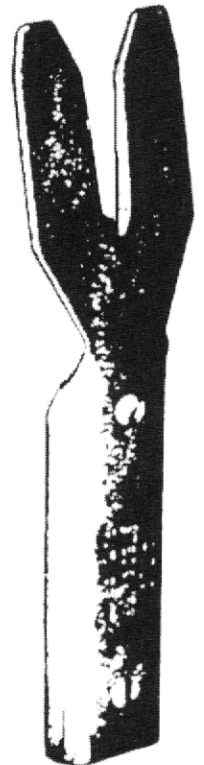

**CC-9**  
**UNIVERSAL CAN CLIPS**  
**PART # CC-9-100 (UNIT PKG.-100)**  
**PART # CC-9-M (UNIT PKG.-1000)**

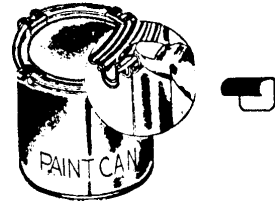

THE CC-9 UNIVERSAL CAN CLIP HAS BEEN DESIGNED TO FIT ROUND PINT, QUART AND GALLON CANS. IT MEETS POSTAL REQUIREMENTS BY LOCKING THE LID INTO POSITION FOR SHIPMENT THRU U.S. POSTAL HANDLING PROCEDURES. EASILY APPLIED WITH THUMB PRESSURE. READILY REMOVED BY A SCREWDRIVER.

**PACKED 100 OR 1000 TO BOX**

**FLAT ACID BRUSHES**



A TIN HANDLE ACID OR ADHESIVE BRUSH MADE OF THE BEST QUALITY BRISTLE AVAILABLE

<u>PART #</u>	<u>SIZE</u>	<u>BRUSH SPECS</u>		<u>OVERALL LENGTH</u>
		<u>WIDTH</u>	<u>LENGTH</u>	
FA-100	#1	3/8"	3/4"	6"
FA-176	#2	1/2"	13/16"	6"
FA-300	#3	9/16"	7/8"	6"

**EACH UNIT PKG.- 144 (1 GROSS)**

**GM-160**  
**DOOR HANDLE**  
**CLIP REMOVER**



**OVERALL LENGTH- 6-1/4"**  
**GM AND FORD**  
**GM-160 INSIDE DOOR**  
**HANDLE REMOVER IS EASY**  
**TO USE!**  
**NO OTHER TOOL**  
**REQUIRED!**  
**NO LOST CLIP! NO CUT**  
**FINGERS! NO SHARP**  
**EDGES! MADE FROM**  
**TEMPERED SPRING STEEL**  
**UNIT PKG.-1**

**SQ-2000**  
**RUBBER SQUEEGEE**

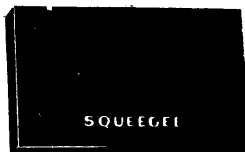

**2" X 3" X 3/16" THICK**  
**AN ECONOMICAL EXTRUDED**  
**SQUEEGEE SUITABLE FOR**  
**APPLYING PUTTY, COLD**  
**SOLDER AND FOR SANDING**  
**OPERATIONS**  
**PACK 100, 250 OR 500 TO A**  
**BOX**

**TP-50**



**SUPER-ADHESIVE**  
**1/2" DOUBLE FACED TAPE**  
**USE TO ATTACH:**  
**MOULDINGS, EMBLEMS, CLIPS**  
**INTERIOR TRIM PANELS,**  
**FASCIA STRIPS AND**  
**MANY MORE APPLICATIONS**  
**UNIT PKG.- 1 ROLL (54 FT.)**

## “METRIC CONVERSION TABLE”

### Millimeter/Decimal/Fractional Equivalents

METRIC	DEC.	FRACT.	METRIC	DEC.	FRACT.	METRIC	DEC.	FRACT.
0.3968mm	.0156"	1/64"	13mm	.5118"		29mm	1.1417"	
0.7924	.0312	1/32	14	.5512		30	1.1811	
1	.0394		14.2875	.5625	9/16"	35	1.3779	
1.5875	.0625	1/16	15	.5905		38.1	1.5000	1 1/2"
2	.0787		15.8750	.625	5/8	40	1.5748	
3	.1181		16	.6299		45	1.7716	
3.175	.1250	1/8	17	.6693		50	1.9685	
4	.1575		18	.7087		50.8	2.000	2
4.7625	.1875	3/16	19	.748		55	2.1653	
5	.1968		19.05	.750	3/4	60	2.3622	
6	.2362		20	.7874		63.5	2.500	2 1/2
6.35	.2500	1/4	21	.8268		65	2.5590	
7	.2756		22	.8661		70	2.7559	
7.9375	.3125	5/16	22.23	.875	7/8	75	2.9527	
8	.3150		23	.9055		76.2	3.000	3
9	.3543		24	.9449		80	3.1496	
9.525	.375	3/8	25	.9842		85	3.3464	
10	.3937		25.4	1.0000	1	90	3.5433	
11	.4331		26	1.0236		95	3.7041	
11.1125	.4375	7/16	27	1.0630		100	3.9370	
12	.4724		28	1.1024		101.6	4.000	4
12.7	.5000	1/2						

## CRT-1 W&E CLIP REMOVAL TOOL

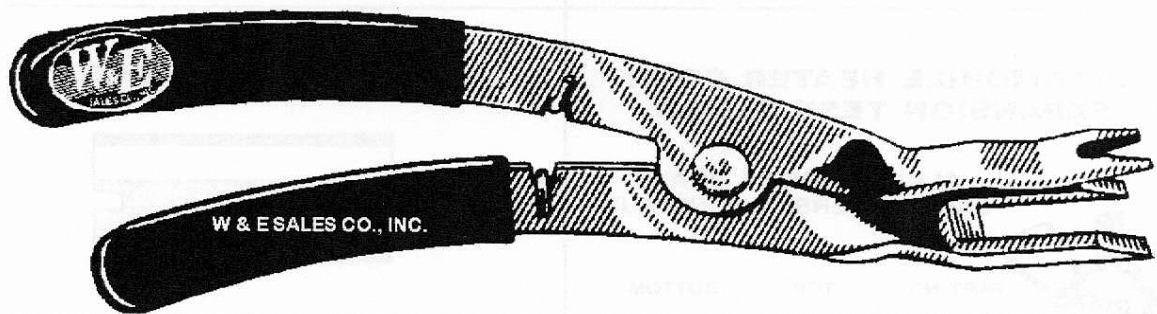

IDEAL TOOL FOR REMOVING CLIPS AND RETAINERS QUICKLY AND EASILY WITHOUT DAMAGE TO THE PANEL. SEAT THE TOOL ON THE SHAFT OF THE CLIP AND SQUEEZE THE HANDLES TOGETHER. HIGH CARBON STEEL, ZINC PLATED WITH MOLDED HANDLE GRIPS. MAKES REMOVING CLIPS AND RETAINERS AN EASIER JOB. PLEASE NOTE: ALWAYS REPLACE OLD CLIPS WITH NEW ONES WHEN RE-INSTALLING THE PANEL.

UNIT PKG.-1

### EXPANSION TEST PLUGS

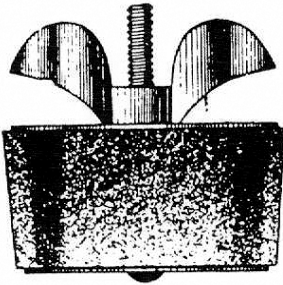

Fits irregular shaped as well as round radiator water connections. Each Expansion Plug is a completely assembled unit of live rubber, brass washers, brass screws and non corrosive wing nut.

PART NO.	TOP DIMENSION	BOTTOM DIMENSION	PIECES TO SET
EP 3	15/16"	3/4"	2
EP 4	1"	7/8"	2
EP 5	1 1/8"	15/16"	2
EP 6	1 1/4"	1"	1
EP 7	1 1/2"	1 1/4"	1
EP 8	1 5/8"	1 3/8"	1
EP 9	1 13/16"	1 1/2"	1
EP 10	2"	1 11/16"	1
EP 11	2 1/4"	1 7/8"	1
EP 12	2 1/2"	2 1/4"	1

EPS 13 – Set consists of 13 plugs.

See price sheets for packaging information.

### FW-25

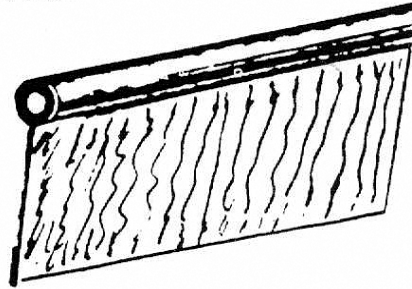

**FENDER WELT  
FOR USE WHEN ATTACHING FENDERS  
VINTAGE CARS**

25 Yard Hank

UNIT PKG-1

### EW-14

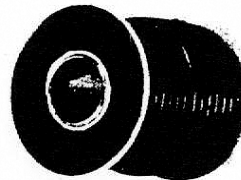

**GENERAL PURPOSE  
PRIMARY WIRE  
Stranded Copper  
SAE Standard Type  
14 gauge – 100' Spool  
Thermoplastic Insulated  
Blue Color**

UNIT PKG. – 1 Roll

### AUTOMOBILE HEATER CORE EXPANSION TEST PLUGS

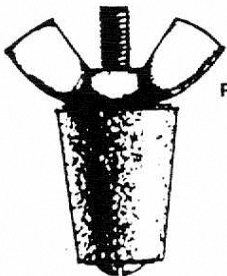

**ALL HARDWARE BRASS  
LARGE OVERSIZE WING NUT**

PART NO.	TOP	BOTTOM
EP-00	5/8"	7/16"
EP-0	1 1/16"	1/2"

EACH UNIT PKG.-1

### RB-1 RAZOR BLADES

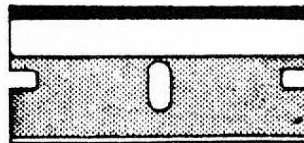























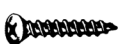

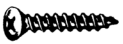











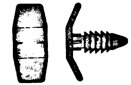





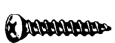

Single Edge, Heavy Duty, First Quality Industrial Blades – a Handy Tool in Any Shop.

Packed 100 to Box

# DRAWER ASSORTMENTS

(STEEL BOX-13-1/4" WIDE; 9-1/4" DEEP & 2" HIGH)  
(FITS IN SLIDE RACKS- #CR-4 AND CR-6)

		<b>SD-1402</b> SHEET METAL SCREW ASSORTMENT					
<b>2389</b>  #6 X 1" PHILLIPS PAN HEAD SHEET METAL SCREW- PLATED	<b>2390</b>  #8 X 3/4" PHILLIPS PAN HEAD SHEET METAL SCREW PLATED	<b>680</b>  #6 X 1/2" PHILLIPS PAN HEAD SHEET METAL SCREW PLATED	<b>622</b>  #8 X 3/8" PHILLIPS FLAT HEAD SHEET METAL SCREW PLATED	<b>636</b>  #8 X 1" (#6 HEAD) PHILLIPS OVAL HEAD SHEET METAL SCREW PLATED	<b>655</b>  #10 X 3/4" (#8 HEAD) PHILLIPS OVAL HEAD SHEET METAL SCREW PLATED		
<b>627</b>  #6 X 1" PHILLIPS OVAL HEAD SHEET METAL SCREW-PLATED	<b>689</b>  #10 X 1" PHILLIPS PAN HEAD SHEET METAL SCREW PLATED	<b>682</b>  #8 X 1/2" PHILLIPS PAN HEAD SHEET METAL SCREW PLATED	<b>633</b>  #8 X 5/8" (#6 HEAD) PHILLIPS OVAL HEAD SHEET METAL SCREW PLATED	<b>637</b>  #8 X 1" PHILLIPS OVAL HEAD SHEET METAL SCREW PLATED	<b>658</b>  #10 X 1" (#6 HEAD) PHILLIPS OVAL HEAD SHEET METAL SCREW		
<b>631</b>  #8 X 1/2" PHILLIPS OVAL HEAD SHEET METAL SCREW-PLATED	<b>2393</b>  #12 X 3/4" PHILLIPS PAN HEAD SHEET METAL SCREW PLATED	<b>684</b>  #10 X 1/2" PHILLIPS PAN HEAD SHEET METAL SCREW PLATED	<b>635</b>  #8 X 3/4" PHILLIPS OVAL HEAD SHEET METAL SCREW PLATED	<b>640</b>  #8 X 1-1/2" (#6 HEAD) PHILLIPS OVAL HEAD SHEET METAL SCREW PLATED	<b>660</b>  #10 X 1-1/2" (#6 HEAD) PHILLIPS OVAL HEAD SHEET METAL SCREW PLATED		
<b>2396</b>  #14 X 3/4" PHILLIPS PAN HEAD SHEET METAL SCREW-PLATED	<b>537</b>  #14 X 3/4" SLOTTED PAN HEAD SHEET METAL SCREW-PLATED	<b>686</b>  #10 X 3/4" PHILLIPS PAN HEAD SHEET METAL SCREW PLATED	<b>2498</b>  #8 X 3/4" (#6 HEAD) PHILLIPS OVAL HEAD SHEET METAL SCREW PLATED	<b>641</b>  #8 X 1-3/4" (#6 HEAD) PHILLIPS OVAL HEAD SHEET METAL SCREW PLATED	<b>2391</b>  #10 X 1-1/2" (#8 HEAD) PHILLIPS PAN HEAD SHEET METAL SCREW PLATED		

		<b>SD-1403</b> UNIVERSAL MOULDING CLIP & PANEL CLIP ASSORTMENT					
<b>1222</b>  RETAINER- HOOD TO COWL- GM & FORD	<b>1036</b>  FINISHING WASHERS COUNTERSUNK #6 SCREW SIZE	<b>2402</b>  WIRE MOULDING CLIP 3/4" MOULDINGS	<b>2254</b>  SIDE & TAILGATE MOULDING CLIP	<b>2109</b>  ROCKER PANEL MOULDING CLIP	<b>156</b>  MOULDING BOLT		
<b>1213</b>  DOOR TRIM PANEL FASTENER- FORD & GM	<b>633</b>  #6 X 5/8" (#6 HEAD) PHILLIPS OVAL HEAD SHEET METAL	<b>332</b>  SIDE MOULDING CLIP 7/16" X 9/16"	<b>1210</b>  DOOR PANEL CLIP REGULAR THROAT	<b>146</b>  MOULDING BOLT 10-24 X 3/4"	<b>147</b>  MOULDING BOLT 10-24 X 3/4"		
<b>1205</b>  DOOR TRIM PANEL FASTENER- GM	<b>1262</b>  INSIDE DOOR HANDLE RETAINING CLIP	<b>333</b>  SIDE MOULDING CLIP 1/2" X 11/16"	<b>336</b>  SIDE MOULDING CLIP 7/8" X 1"	<b>150</b>  MOULDING BOLT 10-24 X 3/4"	<b>161</b>  MOULDING BOLT 10-24 X 3/4"		
<b>777</b>  10-24 HEX NUT USE WITH MOULDING BOLTS	<b>1223</b>  TRIM & PANEL CLIP UPPER GRILLE	<b>175</b>  PUSH-IN (BLIND) MOULDING CLIP 13/16" X 3/8"	<b>2108</b>  RETAINER-FILLER BETWEEN BUMPER & FENDER	<b>1225</b>  PLASTIC SCREW NAIL RETAINER-UNIVERSAL	<b>161</b>  MOULDING BOLT 10-24 X 3/4"		



























**DRAWER ASSORTMENTS**  
 (STEEL BOX-13-1/4" WIDE; 9-1/4" DEEP & 2" HIGH)  
 (FITS IN SLIDE RACKS- #CR-4 AND CR-6)



**SD-1404**  
**CLIPS NUTS, PUSH ON CLIPS & TUBULAR CLIP ASSORTMENT**



























<p>885</p>  <p>PUSH ON CLIPS 1/16" STUD</p>	<p>889</p>  <p>PUSH ON CLIPS 3/16" STUD</p>	<p>876</p>  <p>TUBULAR CLIPS 1/8" STUD</p>	<p>852</p>  <p>CLIP NUT #8 SCREW SIZE</p>	<p>814</p>  <p>CLIP NUT #14 SCREW SIZE</p>	<p>860</p>  <p>CLIP NUT #14 SCREW SIZE</p>
<p>886</p>  <p>PUSH ON CLIPS 3/32" STUD</p>	<p>890</p>  <p>PUSH ON CLIPS 1/4" STUD</p>	<p>874</p>  <p>TUBULAR CLIPS 3/32" STUD</p>	<p>853</p>  <p>CLIP NUT #8 SCREW SIZE</p>	<p>855</p>  <p>CLIP NUT #10 SCREW SIZE</p>	<p>861</p>  <p>LICENSE PLATE CLIP NUT</p>
<p>887</p>  <p>PUSH ON CLIPS 1/8" STUD</p>	<p>879</p>  <p>TUBULAR CLIPS 3/16" STUD (#10 THREAD)</p>	<p>878</p>  <p>TUBULAR CLIPS 3/16" STUD</p>	<p>2346</p>  <p>CLIP NUT</p>	<p>859</p>  <p>CLIP NUT</p>	<p>2255</p>  <p>CLIP NUT -LONG THROAT #8 SCREW SIZE</p>
<p>888</p>  <p>PUSH ON CLIPS 3/32" STUD</p>	<p>875</p>  <p>TUBULAR CLIPS 1/8" STUD</p>	<p>881</p>  <p>TUBULAR CLIPS 3/16" STUD FOR 1/4" HOLE</p>	<p>858</p>  <p>CLIP NUT #10 SCREW SIZE</p>	<p>811</p>  <p>CLIP NUT #8 SCREW SIZE</p>	<p>2164</p>  <p>CLIP NUT #10 SCREW SIZE</p>



**SD-1406**  
**METRIC BOLT AND NUT ASSORTMENT**











































<p>5004</p>  <p>4 X 7 MM HEX NUT DIN 934</p>	<p>5010</p>  <p>10 X 1.5 MM HEX NUT DIN 934</p>	<p>5502</p>  <p>5MM X 20MM CAP SCREW DIN 933</p>	<p>5603</p>  <p>6MM X 25MM CAP SCREW DIN 933</p>	<p>5803</p>  <p>8MM X 25MM CAP SCREW DIN 933</p>	<p>5102</p>  <p>10MM X 20 MM CAP SCREW DIN 933</p>
<p>5005</p>  <p>5 X 8 MM HEX NUT DIN 934</p>	<p>5401</p>  <p>4MM X 16MM CAP SCREW DIN 933</p>	<p>5503</p>  <p>5MM X 25MM CAP SCREW DIN 933</p>	<p>5604</p>  <p>6MM X 30MM CAP SCREW DIN 933</p>	<p>5804</p>  <p>8MM X 30 MM CAP SCREW DIN 933</p>	<p>5103</p>  <p>10MM X 30MM CAP SCREW DIN 933</p>
<p>5006</p>  <p>6 X 1 MM HEX NUT DIN 934</p>	<p>5402</p>  <p>4MM X 20MM CAP SCREW DIN 933</p>	<p>5601</p>  <p>6MM X 16MM CAP SCREW DIN 933</p>	<p>5801</p>  <p>8MM X 16MM CAP SCREW DIN 933</p>	<p>5805</p>  <p>8MM X 35MM CAP SCREW DIN 933</p>	<p>5104</p>  <p>10MM X 30MM CAP SCREW DIN 933</p>
<p>5008</p>  <p>8 X 1.25 MM HEX NUT DIN 934</p>	<p>5501</p>  <p>5MM X 16MM CAP SCREW DIN 933</p>	<p>5602</p>  <p>6MM X 20MM CAP SCREW DIN 933</p>	<p>5802</p>  <p>8MM X 20MM CAP SCREW DIN 933</p>	<p>5806</p>  <p>8MM X 40MM CAP SCREW DIN 933</p>	<p>5106</p>  <p>10MM X 40MM CAP SCREW DIN 933</p>



# DRAWER ASSORTMENTS

(STEEL BOX-13-1/4" WIDE; 9-1/4" DEEP & 2" HIGH)  
(FITS IN SLIDE RACKS- #CR-4 AND CR-6)

		<b>SD-1407 SOLDERLESS TERMINALS ASSORTMENT</b>					
<b>421</b>  RING TONGUES 22-16 WIRE #8-10 STUD SIZE	<b>427</b>  RING TONGUES 12-10 WIRE #8-10 STUD SIZE	<b>432</b>  SPADE TONGUES #12-10 WIRE	<b>440</b>  BUTT CONNECTORS (NYLON) #22-16 WIRE	<b>444</b>  DEAD END CONNECTOR (NYLON)	<b>449</b>  SNAP PLUG #16-14 WIRE (USE WITH W&E #448)		
<b>424</b>  RING TONGUES 16-14 WIRE #8-10 STUD SIZE	<b>428</b>  RING TONGUES 12-10 WIRE	<b>433</b>  SPADE TONGUES #12-10 WIRE	<b>441</b>  BUTT CONNECTORS (NYLON) #16-14 WIRE	<b>445</b>  FEMALE QUICK DISCONNECT #16-14 WIRE (COLOR-BLUE)	<b>450</b>  QUICK ELECTRIC CONNECTOR- SELF STRIPPING		
<b>425</b>  RING TONGUES 16-14 WIRE #12-1/4" STUD SIZE	<b>429</b>  RING TONGUES 12-10 WIRE #12-1/2" STUD SIZE	<b>434</b>  SPADE TONGUES #12-10 WIRE #8-10 STUD SIZE	<b>442</b>  BUTT CONNECTORS (NYLON) #12-10 WIRE (COLOR-YELLOW)	<b>446</b>  MALE QUICK DISCONNECT #16-14 WIRE (COLOR-BLUE)	<b>454</b>  FULLY INSULATED FEMALE QUICK DISCONNECT #16-14 WIRE (COLOR-BLUE)		
<b>426</b>  RING TONGUES 16-14 WIRE 5/16"-3/8" STUD SIZE	<b>430</b>  RING TONGUES 12-10 WIRE	<b>437</b>  HOOK TONGUES #16-14 WIRE	<b>443</b>  DEAD END CONNECTOR (NYLON) #22-14 WIRE	<b>448</b>  STOP LIGHT CONNECTOR #16-14 WIRE	<b>2576</b>  FULLY INSULATED MALE QUICK DISCONNECT #16-14 WIRE (COLOR-BLUE)		

		<b>SD-1455 BLIND RIVET SHOP DISPENSER</b>				
<b>1250 (ABA 4-3)</b>  ALUMINUM SMALL FLANGE PANEL RIVET 1/8" DIAMETER PANEL RANGE UP TO 3/16"	<b>2133 (SBS 5-6)</b>  STEEL DOME HEAD RIVET 5/32" DIAMETER 1/4" TO 3/8" PANEL RANGE	<b>2138 (ABA 6-4)</b>  ALUMINUM DOME HEAD RIVET 3/16" DIAMETER				
<b>2130 (SBS 4-2)</b>  STEEL DOME HEAD RIVET 1/8" DIAMETER	<b>2134 (SCS 4-2)</b>  STEEL COUNTERSUNK HEAD RIVET 1/8" DIAMETER	<b>2139 (ABA 6-6)</b>  ALUMINUM DOME HEAD RIVET 3/16" DIAMETER				
<b>2131 (SBS 4-4)</b>  STEEL DOME HEAD RIVET 1/8" DIAMETER 1/8" TO 1/4" PANEL RANGE	<b>2135 (SCS 4-4)</b>  STEEL COUNTERSUNK HEAD RIVET 1/8" DIAMETER 1/8" TO 1/4" PANEL RANGE	<b>2162 (ABA 66L)</b>  LARGE FLANGE ALUMINUM RIVET				
<b>2132 (SBS 4-6)</b>  STEEL DOME HEAD RIVET 1/8" DIAMETER	<b>2137 (ABA 6-2)</b>  ALUMINUM DOME HEAD RIVET 3/16" DIAMETER UP TO 18" PANEL RANGE	<b>2263 (ABA 610L)</b>  LARGE FLANGE ALUMINUM RIVET 3/16" DIAM., 1/2" TO 5/8" PANEL RANGE				



# DRAWER ASSORTMENTS

(STEEL BOX-13-1/4" WIDE; 9-1/4" DEEP & 2" HIGH)  
(FITS IN SLIDE RACKS- #CR-4 AND CR-6)



## SD-1465 PLASTIC PUSH-IN FASTENER & RIVET ASSORTMENT



























<p><b>1205</b></p>  <p>DOOR TRIM PANEL RETAINER GM, CHRYSLER &amp; FORD</p>	<p><b>1206</b></p>  <p>DOOR WEATHERSTRIP CLIP GM, FORD &amp; UNIVERSAL</p>	<p><b>1222</b></p>  <p>HOOD INSULATION/SPLASH SHIELD CLIP- GM &amp; FORD</p>	<p><b>1223</b></p>  <p>TRIM AND PANEL RETAINER CHRYSLER &amp; UNIVERSAL</p>	<p><b>1224</b></p>  <p>HOOD INSULATION CLIP FORD &amp; CHRYSLER</p>	<p><b>1227</b></p>  <p>HOOD INSULATION CLIP GM AND UNIVERSAL</p>
<p><b>1225</b></p>  <p>BLACK SCREW NAIL RETAINER GM, AMC &amp; UNIVERSAL</p>	<p><b>2279</b></p>  <p>GREY SCREW NAIL RETAINER GM, AMC &amp; UNIVERSAL</p>	<p><b>2104</b></p>  <p>GRILLE RIVET FORD AND UNIVERSAL</p>	<p><b>2105</b></p>  <p>TRIM PANEL RETAINER GM, FORD &amp; CHRYSLER</p>	<p><b>2107</b></p>  <p>TRIM RETAINER GM AND UNIVERSAL</p>	<p><b>1227</b></p>  <p>HOOD INSULATION CLIP GM AND UNIVERSAL</p>
<p><b>2108</b></p>  <p>FENDER AND BUMPER RETAINER GM &amp; UNIVERSAL</p>	<p><b>2117</b></p>  <p>TRIM PANEL FASTENER GM &amp; FORD</p>	<p><b>2140</b></p>  <p>SCREW NAIL RETAINER GM, FORD, CHRYSLER, AMC</p>	<p><b>2462</b></p>  <p>DOOR PANEL FASTENER GM- '82 &amp; UP</p>	<p><b>2223</b></p>  <p>PLASTIC RIVET BUMPER STRIP GM- '81 &amp; UP</p>	<p><b>2230</b></p>  <p>HOOD INSULATION CLIP- GM</p>
<p><b>2190</b></p>  <p>DOOR TRIM RETAINER CHRYSLER PRODUCTS</p>	<p><b>2204</b></p>  <p>PANEL FASTENER GM</p>	<p><b>2512</b></p>  <p>DOOR PANEL CLIP BUMPER STRIP GM</p>	<p><b>2207</b></p>  <p>WEATHERSTRIP CLIP GM &amp; UNIVERSAL</p>	<p><b>2216</b></p>  <p>MUD SKIRT RETAINER AMC, FORD, GM CHRYSLER</p>	<p><b>2230</b></p>  <p>HOOD INSULATION CLIP- GM</p>

























## SD-1466 USS BOLT AND NUT ASSORTMENT

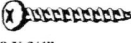
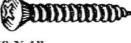

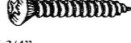

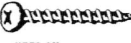
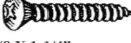









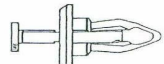

<p><b>4001</b></p>  <p>1/4"-20 HEX NUT ZINC PLATED</p>	<p><b>4005</b></p>  <p>1/2"-13 HEX NUT ZINC PLATED</p>	<p><b>4104</b></p>  <p>1/4 X 1-1/4" CAP SCREW ZINC PLATED</p>	<p><b>4113</b></p>  <p>5/16 X 1" CAP SCREW GRADE 5- ZINC</p>	<p><b>4117</b></p>  <p>5/16 X 2" CAP SCREW GRADE 5- ZINC</p>	<p><b>4127</b></p>  <p>3/8 X 2" CAP SCREW GRADE 5- ZINC</p>
<p><b>4002</b></p>  <p>5/16"-18 HEX NUT ZINC PLATED</p>	<p><b>4101</b></p>  <p>1/4 X 1/2" CAP SCREW GRADE 5- ZINC</p>	<p><b>4105</b></p>  <p>1/4 X 1-1/2" CAP SCREW GRADE 5- ZINC</p>	<p><b>4115</b></p>  <p>5/16 X 1-1/2" CAP SCREW GRADE 5- ZINC</p>	<p><b>4133</b></p>  <p>7/16 X 1" CAP SCREW GRADE 5- ZINC</p>	<p><b>4137</b></p>  <p>7/16 X 2" CAP SCREW GRADE 5- ZINC</p>
<p><b>4003</b></p>  <p>3/8"-16 HEX NUT ZINC PLATED</p>	<p><b>4102</b></p>  <p>1/4 X 3/4" CAP SCREW GRADE 5- ZINC</p>	<p><b>4107</b></p>  <p>1/4 X 2" CAP SCREW GRADE 5- ZINC</p>	<p><b>4123</b></p>  <p>3/8 X 1-1/2" CAP SCREW GRADE 5- ZINC</p>	<p><b>4135</b></p>  <p>7/16 X 1-1/2" CAP SCREW GRADE 5- ZINC</p>	<p><b>4147</b></p>  <p>1/2 X 2" CAP SCREW GRADE 5- ZINC</p>
<p><b>4004</b></p>  <p>7/16"-14 HEX NUT ZINC PLATED</p>	<p><b>4103</b></p>  <p>1/4 X 1" CAP SCREW GRADE 5- ZINC</p>	<p><b>4112</b></p>  <p>5/16 X 3/4" CAP SCREW GRADE 5- ZINC</p>	<p><b>4125</b></p>  <p>3/8 X 1-1/2" CAP SCREW GRADE 5- ZINC</p>	<p><b>4145</b></p>  <p>1/2 X 1-1/2" CAP SCREW GRADE 5- ZINC</p>	<p><b>4149</b></p>  <p>1/2 X 2-1/2" CAP SCREW GRADE 5- ZINC</p>



**DRAWER ASSORTMENTS**  
 (STEEL BOX-13-1/4" WIDE; 9-1/4" DEEP & 2" HIGH)  
 (FITS IN SLIDE RACKS- #CR-4 AND CR-6)

		<b>SD-1467 BLACK SHEET METAL SCREW ASSORTMENT</b>					
<p><b>673</b></p>  #8 X 1/2" PHILLIPS OVAL HEAD SHEET METAL SCREW BLACK OXIDE PLATED	<p><b>2148</b></p>  #8 X 1/2" PHILLIPS PAN HEAD SHEET METAL SCREW BLACK	<p><b>2331</b></p>  #8 X 1/2" PHILLIPS OVAL HEAD SHEET METAL SCREW BLACK OXIDE PLATED	<p><b>2225</b></p>  4.2 X 10 MM PHILLIPS FLAT WASHER HEAD SHEET METAL SCREW	<p><b>2193</b></p>  4.2 X 20 MM INDENTED HEX HD SHEET METAL SCREW-W/ LOOSE WSHR BLACK	<p><b>2296</b></p>  #8X3/4" PHILLIPS OVAL FINISHING SEMS COUNTERSUNK WASHER		
<p><b>674</b></p>  #8 X 3/4" #6 HD. PHILLIPS OVAL HEAD SHEET METAL SCREW BLACK OXIDE PLATED	<p><b>2149</b></p>  #10 X 1" PHILLIPS PAN HEAD SHEET METAL SCREW BLACK	<p><b>2332</b></p>  #8 X 3/4" PHILLIPS OVAL HEAD SHEET METAL SCREW BLACK OXIDE PLATED	<p><b>2226</b></p>  4.2 X 20 MM PHILLIPS FLAT WASHER HEAD SHEET METAL SCREW BLACK	<p><b>3316</b></p>  4.2 X 13 MM PHILLIPS PAN HD-SCREW-AB W/ 12 MM FREE SPINNING WASHER BLACK	<p><b>2297</b></p>  #8 X 1" PHILLIPS OVAL FINISHING SEMS COUNTERSUNK WASHER BLACK		
<p><b>675</b></p>  #8 X 1" #6 HD PHILLIPS OVAL HEAD SHEET METAL SCREW BLACK OXIDE PLATED	<p><b>2319</b></p>  #8 X 3/4" PHILLIPS PAN HEAD SHEET METAL SCREW BLACK	<p><b>2333</b></p>  #8 X 1" PHILLIPS OVAL HEAD SHEET METAL SCREW BLACK OXIDE PLATED	<p><b>2227</b></p>  4.2 X 13 MM PHILLIPS ROUND WASHER HEAD SHEET METAL SCREW BLACK	<p><b>2322</b></p>  4.2 X 20 MM HEX HEAD SHEET METAL SCREW-WITH LOOSE WASHER BLACK	<p><b>2335</b></p>  #10 X 3/4" PHILLIPS OVAL HEAD SHEET METAL SCREW BLACK OXIDE PLATED		
<p><b>676</b></p>  #8 X 1-1/4" #6 HD. PHILLIPS OVAL HEAD SHEET METAL SCREW BLACK OXIDE PLATED	<p><b>2320</b></p>  #8 X 1" PHILLIPS PAN HEAD SHEET METAL SCREW BLACK	<p><b>2334</b></p>  #8 X 1-1/4" PHILLIPS OVAL HEAD SHEET METAL SCREW BLACK OXIDE PLATED	<p><b>2345</b></p>  #8 X 3/4" PHILLIPS ROUND WASHER HEAD SHEET METAL SCREW BLACK	<p><b>2340</b></p>  4.2 X 13 MM PHILLIPS FLAT WASHER HEAD SELF DRILLING SCREW BLACK	<p><b>2325</b></p>  4.2 X 10 MM PHILLIPS ROUND WASHER HEAD SHEET METAL SCREW BLACK		

		<b>SD-1470 PLASTIC DRIVE RIVET ASSORTMENT</b>			
<p><b>2216</b></p>  FRONT FENDER MUD SKIRT ATTACHING-GM	<p><b>2388</b></p>  BUMPER FASCIA/ GENERAL USE GM, FORD	<p><b>2437</b></p>  BUMPER FASCIA GENERAL USE-GM			
<p><b>2223</b></p>  FRONT & REAR ATTACHING STRIP (BLACK) - GM BUMPER	<p><b>2398</b></p>  PLASTIC DRIVE RIVET- (6.3 MM HOLE) GM, FORD, AMC & CHRYSLER	<p><b>2438</b></p>  BUMPER FASCIA GENERAL USE-GM			
<p><b>2550</b></p>  NYLON PUSH RIVET- (8 MM HOLE) GM, C,K TRUCK, FORD & CHRYSLER	<p><b>2399</b></p>  PLASTIC DRIVE RIVET- (8 MM HOLE) GM, FORD & CHRYSLER	<p><b>2453</b></p>  FASCIA RETAINER (8MM HOLE) GM & CHRYSLER			
<p><b>2974</b></p>  PLASTIC DRIVE RIVET- BUMPER FASCIA- GM	<p><b>2420</b></p>  PUSH TYPE RIVET- (8 MM HOLE) GM, FORD	<p><b>2458</b></p>  SPLASH SHIELD, FASCIA RETAINER ( 6 MM HOLE) FORD & CHRYSLER			



















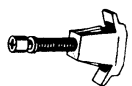

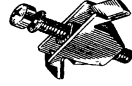

## DRAWER ASSORTMENTS

(STEEL BOX-13-1/4" WIDE; 9-1/4" DEEP & 2" HIGH)  
(FITS IN SLIDE RACKS- #CR-4 AND CR-6)

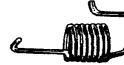

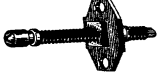
### SD-2100 HEADLAMP PARTS ASSORTMENT

















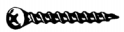









<p><b>2248</b></p>  <p>HEADLAMP ADJUSTING NUT- TOYOTA</p>	<p><b>2124</b></p>  <p>HEADLAMP ADJUSTING NUT-GM</p>	<p><b>1010</b></p>  <p>HEADLAMP ADJUSTING ASSEMBLY-CHRYSLER</p>	<p><b>1041</b></p>  <p>HEADLAMP ADJUSTING SCREW- 12-28 X 1-3/4"</p>	<p><b>2700</b></p>  <p>HEADLAMP RETAINER FORD RANGER-</p>	<p><b>2235</b></p>  <p>HEADLAMP ADJUSTING ASSEMBLY- FORD</p>
<p><b>835</b></p>  <p>HEADLAMP ADJUSTING ASSEMBLY- CHRYSLER</p>	<p><b>1034</b></p>  <p>HEADLAMP ADJUSTING ASSEMBLY-GM</p>	<p><b>1055</b></p>  <p>HEADLAMP ADJUSTING ASSEMBLY- GM</p>	<p><b>2118</b></p>  <p>HEADLAMP ADJUSTING ASSEMBLY- FORD</p>	<p><b>2534</b></p>  <p>HEADLAMP RETAINER TAURUS, SABLE, T-BIRD- TEMPO/TOPAZ</p>	<p><b>840</b></p>  <p>HEADLAMP ADJUSTING RING BEARING- FORD</p>
<p><b>837</b></p>  <p>HEADLAMP ADJUSTING NUT- GM</p>	<p><b>2268</b></p>  <p>HEADLAMP ADJUSTING ASSEMBLY-CHRYSLER</p>	<p><b>1013</b></p>  <p>HEADLAMP ADJUSTING ASSEMBLY-CHRYSLER</p>	<p><b>2212</b></p>  <p>HEADLAMP ADJUSTING NUT- NISSAN, TOYOTA</p>	<p><b>1024</b></p>  <p>HEADLAMP SPRING GM</p>	<p><b>1040</b></p>  <p>HEADLAMP ADJUSTING SCREW- 1/4-28 X 2"</p>
<p><b>839</b></p>  <p>HEADLAMP ADJUSTING NUT-GM</p>	<p><b>1025</b></p>  <p>HEADLAMP ADJUSTING ASSEMBLY-FORD</p>	<p><b>1012</b></p>  <p>HEADLAMP ADJUSTING ASSEMBLY-CADILLAC</p>	<p><b>2211</b></p>  <p>HEADLAMP ADJUSTING SCREW-NISSAN, TOYOTA</p>	<p><b>2244</b></p>  <p>HEADLAMP BEZEL NUT NATURAL COLOR- GM</p>	<p><b>1011</b></p>  <p>HEADLAMP ADJUSTING ASSEMBLY- GM</p>



### 1725 SHEET METAL SCREW ASSORTMENT

















<p><b>2389</b></p>  <p>#6 X 1" PHILLIPS PAN HEAD SHEET METAL SCREW- PLATED</p>	<p><b>2390</b></p>  <p>#8 X 3/4" PHILLIPS PAN HEAD SHEET METAL SCREW PLATED</p>	<p><b>680</b></p>  <p>#6 X 1/2" PHILLIPS PAN HEAD SHEET METAL SCREW PLATED</p>	<p><b>622</b></p>  <p>#8 X 3/8" PHILLIPS FLAT HEAD SHEET METAL SCREW PLATED</p>	<p><b>636</b></p>  <p>#8 X 1" (#6 HEAD) PHILLIPS OVAL HEAD SHEET METAL SCREW PLATED</p>	<p><b>655</b></p>  <p>#10 X 3/4" (#8 HEAD) PHILLIPS OVAL HEAD SHEET METAL SCREW PLATED</p>
<p><b>627</b></p>  <p>#6 X 1" PHILLIPS OVAL HEAD SHEET METAL SCREW-PLATED</p>	<p><b>689</b></p>  <p>#10 X 1" PHILLIPS PAN HEAD SHEET METAL SCREW PLATED</p>	<p><b>682</b></p>  <p>#8 X 1/2" PHILLIPS PAN HEAD SHEET METAL SCREW PLATED</p>	<p><b>633</b></p>  <p>#8 X 5/8" (#6 HEAD) PHILLIPS OVAL HEAD SHEET METAL SCREW PLATED</p>	<p><b>637</b></p>  <p>#8 X 1" PHILLIPS OVAL HEAD SHEET METAL SCREW PLATED</p>	<p><b>658</b></p>  <p>#10 X 1" (#6 HEAD) PHILLIPS OVAL HEAD SHEET METAL SCREW PLATED</p>
<p><b>631</b></p>  <p>#8 X 1/2" PHILLIPS OVAL HEAD SHEET METAL SCREW-PLATED</p>	<p><b>2393</b></p>  <p>#12X 3/4" PHILLIPS PAN HEAD SHEET METAL SCREW PLATED</p>	<p><b>684</b></p>  <p>#10 X 1/2" PHILLIPS PAN HEAD SHEET METAL SCREW PLATED</p>	<p><b>635</b></p>  <p>#8 X 3/4" PHILLIPS OVAL HEAD SHEET METAL SCREW PLATED</p>	<p><b>640</b></p>  <p>#8X 1-1/2" (#6 HEAD) PHILLIPS OVAL HEAD SHEET METAL SCREW PLATED</p>	<p><b>660</b></p>  <p>#10 X 1-1/2" (#6 HEAD) PHILLIPS OVAL HEAD SHEET METAL SCREW PLATED</p>
<p><b>2396</b></p>  <p>#14 X 3/4" PHILLIPS PAN HEAD SHEET METAL SCREW-PLATED</p>	<p><b>537</b></p>  <p>#14 X 3/4" SLOTTED PAN HEAD SHEET METAL SCREW-PLATED</p>	<p><b>686</b></p>  <p>#10 X 3/4" PHILLIPS PAN HEAD SHEET METAL SCREW PLATED</p>	<p><b>2498</b></p>  <p>#8 X 3/4" (#6 HEAD) PHILLIPS PAN HEAD SHEET METAL SCREW PLATED</p>	<p><b>641</b></p>  <p>#8 X 1-3/4" (#6 HEAD) PHILLIPS OVAL HEAD SHEET METAL SCREW PLATED</p>	<p><b>2391</b></p>  <p>#10 X 1-1/2" (#8 HEAD) PHILLIPS PAN HEAD SHEET METAL SCREW PLATED</p>

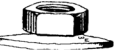

## DRAWER ASSORTMENTS

(STEEL BOX-13-1/4" WIDE; 9-1/4" DEEP & 2" HIGH)  
(FITS IN SLIDE RACKS- #CR-4 AND CR-6)

		<b>SD-5900</b> <b>METRIC BOLT AND NUT ASSORTMENT</b>		
<b>5920</b>  6 MM FOLDOVER NUT GM & UNIVERSAL	<b>5923</b>  6 MM X 20 MM BODY BOLT- WITH 17MM LOOSE WASHER, CA POINT GM AND UNIVERSAL	<b>5909</b>  10 MM FLANGE NUT (21 MM FLANGE DIAMETER) GM & UNIVERSAL		
<b>5902</b>  8MM FOLDOVER NUT GM & UNIVERSAL- '77 AND UP	<b>5906</b>  8MM X 25MM HEX WASHER HEAD BODY BOLT- CA POINT GM AND UNIVERSAL- '77 AND UP	<b>5910</b>  8MM X 30MM BODY BOLT GM AND UNIVERERSAL- '77 AND UP		
<b>5903</b>  8MM LONG THROAT FOLDOVER NUT GM & UNIVERSAL- '77 AND UP	<b>5922</b>  6MM HEX NUT WITH FREE SPINNING 16MM WASHER GM AND UNIVERSAL	<b>5911</b>  10 MM X 40 MM BODY BOLT GM-& UNIVERSAL '77 & UP		
<b>5904</b>  10 MM FOLDOVER NUT GM AND UNIVERSAL - '77 & UP	<b>5908</b>  8MM HEX NUT WITH FREE SPINNING WASHER GM AND UNIVERSAL- '77 AND UP	<b>5911</b>  10 MM X 40 MM BODY BOLT GM-& UNIVERSAL '77 & UP		

## PLASTIC DISPENSER ASSORTMENTS

(PLASTIC BOX-11" X 6-3/4" X 1-3/4")

		<b>WSC-240</b> <b>WEATHERSTRIP CLIP ASSORTMENT</b>					
<b>1206</b>  WEATHERSTRIP RETAINER V- PLASTIC NAIL FASTENER 3/16" HOLE GM & UNIVERSAL	<b>2207</b>  WEATHERSTRIP RETAINER V- GENERAL USE 3/16" HOLE GM & UNIVERSAL	<b>2379</b>  WEATHERSTRIP RETAINER V- TRIM PANEL CLIP 5 MM HOLE NISSAN, TOYOTA & HONDA	<b>2414</b>  WEATHERSTRIP RETAINER V- PANEL RETAINER GM, FORD & AMC	<b>2618</b>  WEATHERSTRIP RETAINER 5 MM HOLE HONDA, NISSAN	<b>2628</b>  WEATHERSTRIP RETAINER GM (SATURN) CHRYSLER		
<b>2652</b>  WEATHERSTRIP RETAINER 5 MM HOLE GM & CHRYSLER	<b>2759</b>  WEATHERSTRIP RETAINER CHEVY, BUICK, PONTIAC & OLDS.	<b>2766</b>  WEATHERSTRIP RETAINER 5 MM HOLE HONDA	<b>2844</b>  WEATHERSTRIP RETAINER 5 MM HOLE FORD & HONDA	<b>2845</b>  WEATHERSTRIP RETAINER 5.5 MM HOLE GM	<b>2848</b>  WEATHERSTRIP RETAINER 5 MM HOLE GM & CHRYSLER		

## PLASTIC DISPENSER ASSORTMENTS

(PLASTIC BOX-11" X 6-3/4" X 1-3/4")

<b>HST-65</b> <b>HEAT SHRINK TERMINAL ASSORTMENT</b>					
<b>2811</b>    <b>HEAT SHRINK BUTT CONNECTOR</b> 22-18 WIRE SIZE RED	<b>2812</b>    <b>HEAT SHRINK BUTT CONNECTOR</b> 16-14 WIRE SIZE BLUE	<b>2812</b>    <b>HEAT SHRINK BUTT CONNECTOR</b> 16-14 WIRE SIZE BLUE	<b>2813</b>    <b>HEAT SHRINK BUTT CONNECTOR</b> 12-10 WIRE SIZE YELLOW	<b>2814</b>    <b>FULLY INSULATED QUICK CONNECT (FEMALE)</b> 22-18 WIRE SIZE RED	<b>2815</b>    <b>FULLY INSULATED QUICK CONNECT (MALE)</b> 22-18 WIRE SIZE RED
<b>2816</b>    <b>FULLY INSULATED QUICK CONNECT (FEMALE)</b> 16-14 WIRE SIZE BLUE	<b>2817</b>    <b>FULLY INSULATED QUICK CONNECT (MALE)</b> 16-14 WIRE SIZE BLUE	<b>2818</b>    <b>FULLY INSULATED QUICK CONNECT (FEMALE)</b> 12-10 WIRE SIZE YELLOW	<b>2819</b>    <b>FULLY INSULATED QUICK CONNECT (MALE)</b> 12-10 WIRE SIZE YELLOW	<b>2820</b>    <b>SNAP PLUG (MALE)</b> 16-14 WIRE SIZE BLUE	<b>2821</b>    <b>SNAP PLUG (FEMALE)</b> 16-14 WIRE SIZE BLUE

<b>CRA-500</b> <b>DOOR LOCK ROD END CLIP ASSORTMENT</b>					
<b>2505</b>    <b>RIGHT HAND CHRYSLER</b>	<b>2506</b>    <b>LEFT HAND CHRYSLER</b>	<b>2507</b>    <b>LEFT HAND CHRYSLER, FORD, GM &amp; AMC</b>	<b>2508</b>    <b>RIGHT HAND CHRYSLER FORD &amp; AMC</b>	<b>2509</b>    <b>RIGHT HAND CHRYSLER GM</b>	<b>2510</b>    <b>LEFT HAND CHRYSLER GM</b>
<b>2625</b>    <b>RIGHT HAND CHRYSLER GM</b>	<b>2273</b>    <b>METAL DOOR LOCK CLIP GM GENERAL USE</b>	<b>2538</b>    <b>BUICK, CADILLAC OLDSMOBILE, PONTIAC &amp; SATURN</b>	<b>2941</b>    <b>RIGHT &amp; LEFT HAND-CHEVY S&amp;T, S-10 PICKUP</b>	<b>2951</b>    <b>DOOR &amp; TAIL GATE LOCKS GM, FORD &amp; FORD TRUCKS</b>	<b>3012</b>    <b>GM, CHEVY VANS</b>

# PLASTIC DISPENSER ASSORTMENTS

(PLASTIC BOX-11" x 6-3/4" x 1-3/4")

<b>TCN-400</b> <b>THREAD CUTTING NUT</b> <b>ASSORTMENT</b>					
<b>920</b>    <b>1/8" STUD</b> <b>17/32" FLANGE</b>	<b>5990</b>    <b>1/8" STUD</b> <b>35/64" FLANGE</b>	<b>923</b>    <b>5/32" STUD</b> <b>9/16" FLANGE</b>	<b>921</b>    <b>3/16" STUD</b> <b>9/16" FLANGE</b>	<b>922</b>    <b>1/4" STUD</b> <b>19/32" FLANGE</b>	<b>2562</b>    <b>1/4" STUD</b> <b>11/16" FLANGE</b>
<b>5990</b>    <b>3.2 MM STUD</b> <b>14 MM FLANGE</b>	<b>5913</b>    <b>4 MM STUD</b> <b>15 MM FLANGE</b>	<b>5914</b>    <b>5 MM STUD</b> <b>15 MM FLANGE</b>	<b>3184</b>    <b>5 MM THREAD</b> <b>14 MM FLANGE</b>	<b>2790</b>    <b>6 MM THREAD</b> <b>18 MM FLANGE</b>	<b>5946</b> <b>REPLACES #928</b>    <b>8 MM STUD</b> <b>20 MM FLANGE</b>

<b>CLN-340</b> <b>CLIP NUT</b> <b>ASSORTMENT</b>					
<b>2346</b>    <b>"U" TYPE</b> <b>#6 SCREW</b>	<b>852</b>    <b>"U" TYPE</b> <b>#8A SCREW</b>	<b>853</b>    <b>"J" TYPE</b> <b>#8A SCREW</b>	<b>811</b>    <b>"U" TYPE</b> <b>#8 SCREW</b>	<b>846</b>    <b>"U" TYPE</b> <b>#8A SCREW</b>	<b>2255</b>    <b>"U" TYPE</b> <b>LONG THROAT</b> <b>#8A OR 4.2</b> <b>SCREW</b>
<b>2164</b>    <b>"U" TYPE</b> <b>WIDE PANEL</b> <b>#10A SCREW</b>	<b>858</b>    <b>"U" TYPE</b> <b>#10A SCREW</b>	<b>859</b>    <b>"U" TYPE</b> <b>#10A SCREW</b>	<b>814</b>    <b>"U" TYPE</b> <b>#14 SCREW</b>	<b>2708</b>    <b>"U" TYPE</b> <b>WIDE PANEL</b> <b>#14 SCREW</b>	<b>860</b>    <b>"J" TYPE</b> <b>#14A (1/4")</b> <b>SCREW</b>

<b>PRT-70</b> <b>PLASTIC RETAINER CLIP AND TOOL</b> <b>ASSORTMENT</b>					
<b>CRT-1-CLIP REMOVAL TOOL</b>  					
<b>2140</b>    <b>SCREW NAIL</b> <b>RETAINER-</b> <b>YOKE SHIELD TO</b> <b>SUPPORT</b> <b>MOULDING,</b> <b>FENDERS, ETC.</b> <b>1/4" HOLE</b> <b>LONGER THAN #1225</b> <b>GM, CHRYSLER,</b> <b>FORD, AMC</b>	<b>2204</b>    <b>PANEL</b> <b>FASTENER-</b> <b>RADIATOR SKIRT</b> <b>ATTACHING</b> <b>CADILLAC &amp; GM</b>	<b>2347</b>    <b>INTERIOR TRIM</b> <b>CLIP- BLACK</b> <b>7MM HOLE; 20MM</b> <b>HEAD</b> <b>30MM GRIP RANGE</b> <b>GM, FORD &amp;</b> <b>UNIVERSAL</b>	<b>2356</b>    <b>BUMPER FASCIA</b> <b>RETAINER</b> <b>10MM HOLE; 25MM STEM</b> <b>21MM HEAD DIAMETER</b> <b>GM, FORD, AMC,</b> <b>CHRYSLER</b> <b>'85 &amp; UP</b>	<b>2274</b>    <b>DOOR PANEL</b> <b>FASTENER</b> <b>PLASTIC, GM-</b> <b>'83 &amp; UP</b>	<b>2224</b>    <b>DOOR TRIM TO</b> <b>INNER PANEL</b> <b>FASTENER</b> <b>GM - '77 TO '82</b>













# PLASTIC DISPENSER ASSORTMENTS

(PLASTIC BOX-11" x 6-3/4" x 1-3/4")



## NRA-60 NYLON BLIND RIVET ASSORTMENT

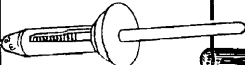

<b>2264</b>  NYLON BLIND RIVET HOLE DIAM: 5 MM (3/16") PANEL RANGE- 3MM- 6MM(1/8"-1/4") HEAD DIAM.- 12 MM (1/2")	<b>2265</b>  NYLON BLIND RIVET HOLE DIAM: 5 MM (3/16") PANEL RANGE- 6 MM-10 MM (1/4"-3/8") HD DIAM-12MM (1/2")	<b>2266</b>  NYLON BLIND RIVET HOLE DIAM: 6.3 MM (1/4") PANEL RANGE- 4 MM- 10 MM (5/32"-3/8") HD DIAM-17MM (11/16")	<b>2267</b>  NYLON BLIND RIVET HOLE DIAM: 6.63 MM (1/4") PANEL RANGE- 2.5 MM- 5 MM 3/32"-3/16") HEAD DIAM.- 18 MM (45/64")	<b>2270</b>  NYLON BLIND RIVET HOLE DIAM: 6.63 MM (1/4") PANEL RANGE- 2.5 MM- 5 MM (3/32"-3/16") HEAD DIAMETER- 13.08MM (1/2")	<b>2355</b>  NYLON BLIND RIVET PANEL RANGE- 6MM-10 5 MM RECTANGULAR HD- 8 MM X 15 MM 3.96 MM DIAM. COWL VENT GRILLE FORD AEROSTAR
<b>2439</b>  NYLON BLIND RIVET HOLE DIAM: 7 MM (9/32") PANEL RANGE- 2.5 MM- 6 MM (3/32"-15/64") HD DIAM.- 18 MM (45/64")	<b>2485</b>  NYLON BLIND RIVET HOLE DIAM: 6.3 MM (1/4") PANEL RANGE 4 MM- 10 MM (5/32"-3/8") HEAD DIAM.- 13 MM (1/2")	<b>2640</b>  NYLON BLIND RIVET HOLE DIAM: 5 MM (3/16") PANEL RANGE- 3 MM- 4 MM (1/8"-5/32") HEAD DIAM.- 9 MM (23/64")	<b>2641</b>  NYLON BLIND RIVET HOLE DIAM: 6 MM (1/4") PANEL RANGE- 4 MM- 8.5 MM (5/32"-21/64") HD DIAM.-13 MM (1/2")	<b>2642</b>  COUNTERSUNK NYLON BLIND RIVET HOLE DIAM: 6.3 MM (1/4") PANEL RANGE- .07 MM-4.5 MM (1/32"-11/64") 2 MM SHOULDER HEAD DIAM.- 17 MM	<b>2653</b>  NYLON BLIND RIVET HOLE DIAM: 6.3 MM (1/4") PANEL RANGE- 8 MM- 12 MM (5/16"-1/2") HEAD DIAM.- 16.8 MM (21/32")





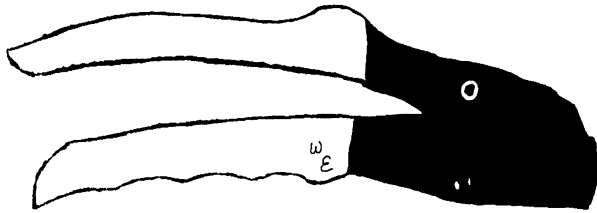

## NKS-50 PLASTIC RIVET & RIVET TOOL ASSORTMENT



IT IS EASY, MANAGEABLE AND FAST TO WORK WITH THE W&E NK-5 PLASTIC RIVETING TOOL IF YOU FOLLOW THESE DIRECTIONS:

1. OPEN HANDLES OF TOOL TO FULLEST EXTENT.
2. PLACE THE RIVET IN THE MOUTHPIECE OF THE OPEN PLIERS.
3. PLACE THE RIVET IN THE DRILLED HOLE.
4. PRESS TOGETHER UNTIL THE MANDREL BREAKS OFF.

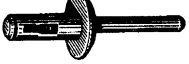
<b>2264</b>  5MM RIVET 3-6MM PANELRANGE	<b>2265</b>  5MM RIVET 6-10MM PANEL RANGE	<b>2266</b>  6.3MM RIVET 4-10MM PANELRANGE	<b>2266</b>  6.3MM RIVET 4-10MM PANELRNGE	<b>2267</b>  6.63MM RIVET 2.5-5MM PANELRNGE	<b>2270</b>  6.63MM RIVET 2.5-5MM PANELRNGE
---	---	--	---	--	---





**LARGE PLASTIC DRAWER ASSORTMENTS**  
**DRAWER SIZE - 13-1/8" X 9" X 2-5/16"**

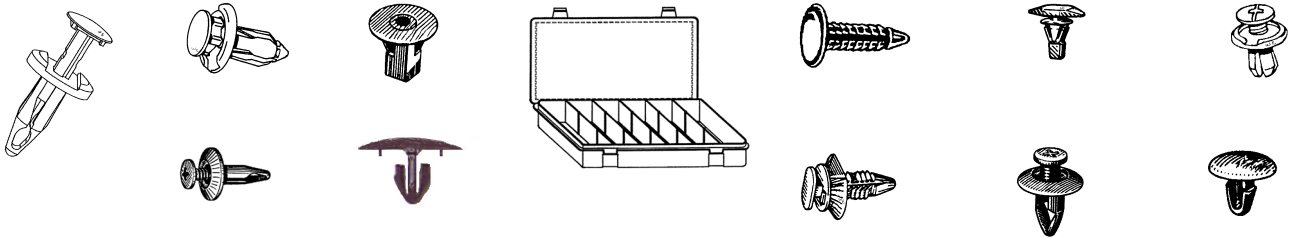

<b><u>PART #</u></b>	<b><u>DESCRIPTION</u></b>
<b>PLA-801</b>	<b>PUSH AND SCREW RIVETS (315 PCS.)</b> <b>(CONTAINS W&amp;E #S-2216,2398,2399,2415,2460,2550,2551,2739,2757,2887,2902,2931)</b>
<b>PLA-802</b>	<b>CHRISTMAS TREE RETAINERS (500 PCS.)</b> <b>(CONTAINS W&amp;E #S-1225,2140,2204,2347,2356,2365,2461,2629,2643,2644,2992,3006)</b>
<b>PLA-803</b>	<b>DOOR PANEL RETAINERS (375 PCS.)</b> <b>(CONTAINS W&amp;E #S-1223,2274,2286,2364,2455,2490,2511,2561,2727,2760,2785,3046)</b>
<b>PLA-804</b>	<b>WEATHERSTRIP CLIPS (650 PCS.)</b> <b>(CONTAINS W&amp;E #S-1206,2207,2379,2414,2618,2628,2652,2759,2844,2845,2848,2933)</b>
<b>PLA-805</b>	<b>GROMMETS (510 PCS.)</b> <b>(CONTAINS W&amp;E #S-817,818,819,822,2244,2277,2339,2374,2494,2503,2756,3063)</b>
<b>PLA-806</b>	<b>HONDA PUSH RIVETS AND RETAINERS (225 PCS.)</b> <b>(CONTAINS W&amp;E #S-2598,2615,2687,2883,2886,2889,2898,2966,2973,3083,3109,3119)</b>
<b>PLA-807</b>	<b>HONDA SCREW RIVETS AND RETAINERS (200 PCS.)</b> <b>(CONTAINS W&amp;E #S-2475,2491,2548,2549,2609,2613,2716,2758,2884,2897,2948,3075)</b>
<b>(ALL ASSORTMENTS PACKED IN W&amp;E PART #PL-12)</b>	
<b>USE WITH PLR-5 RACK (NOT INCLUDED)</b>	

UNIT PKG.-1 EACH



# LARGE PLASTIC DRAWER ASSORTMENTS

DRAWER SIZE - 13-1/8" X 9" X 2-5/16"

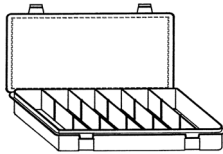

## PART #

## DESCRIPTION

**PLA-808 TOYOTA RIVETS AND RETAINERS (190 PCS.)**

(CONTAINS W&E #S-2366,2387,2440,2495,2496,2523,2655,2686,2885,2958,2961,2991)

**PLA-809 TOYOTA RETAINERS (245 PCS.)**

(CONTAINS W&E #S-2375,2417,2492,2493,2851,2893,2913,2962,2972,3017,3095,3100)

**PLA-810 NISSAN RETAINERS (225 PCS.)**

(CONTAINS W&E #S-2361,2477,2583,2592,2599,2614,2617,2627,2959,2990,3040,3093)

**PLA-811 NYLON RIVETS (300 PCS.)**

(CONTAINS W&E #S-2264,2265,2266,2267,2270,2355,2439,2485,2640,2641,2642,2653)

**PLA-812 PLASTIC RETAINERS-(475 PCS.)**

(CONTAINS W&E #S-2223,2388,2420,2437,2438,2682,2923,2977,3008,3013,3058,3107)

**PLA-813 PLASTIC RETAINERS-(300 PCS.)**

(CONTAINS W&E #S-2453,2458,2699,3023,3078,3210,3212,3215,3224,3244,3245,3260)

**PTR-241\* IMPORT PUSH TYPE RETAINERS-(174 PCS.)**

(CONTAINS W&E #S-2599,2614,2615,2883,2885,2886,2889,2898,2958,2959,2991,3040,  
3093,3109,3171,3194,3202,3216,3229,3232,3235,3242,3246,3254)

\* PACKED IN W&E PART #PL-24

(ALL ASSORTMENTS PACKED IN W&E PART #PL-12)

USE WITH PLR-5 RACK (NOT INCLUDED)

UNIT PKG.-1 EACH

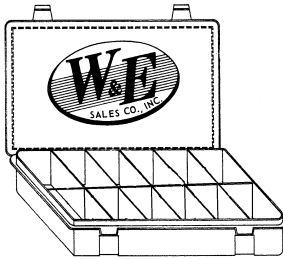

## PLASTIC DISPENSER ASSORTMENTS PARTS LISTING

(POLYPROPYLENE BOX - 11" X 6-3/4" X 1-3/4")













**FOR DETAILS ON ALL W&E PLASTIC DISPENSER  
ASSORTMENTS SEE PAGES-156 AND 157**

<p style="text-align: center;"><b>PD-121</b></p> <p style="text-align: center;"><u>PARTS LISTING</u></p> <table style="width: 100%; border: none;"> <tr><td>2361</td><td>2104</td></tr> <tr><td>2366</td><td>2399</td></tr> <tr><td>2405</td><td>2216</td></tr> <tr><td>2902</td><td>2420</td></tr> <tr><td>2388</td><td>2438</td></tr> <tr><td>2398</td><td>2223</td></tr> </table>	2361	2104	2366	2399	2405	2216	2902	2420	2388	2438	2398	2223	<p style="text-align: center;"><b>PD-122</b></p> <p style="text-align: center;"><u>PARTS LISTING</u></p> <table style="width: 100%; border: none;"> <tr><td>1205</td><td>2140</td></tr> <tr><td>2224</td><td>1225</td></tr> <tr><td>2105</td><td>2512</td></tr> <tr><td>2286</td><td>2204</td></tr> <tr><td>2117</td><td>2347</td></tr> <tr><td>1223</td><td>2107</td></tr> </table>	1205	2140	2224	1225	2105	2512	2286	2204	2117	2347	1223	2107	<p style="text-align: center;"><b>PD-123</b></p> <p style="text-align: center;"><u>PARTS LISTING</u></p> <table style="width: 100%; border: none;"> <tr><td>5906</td><td>5952</td></tr> <tr><td>5910</td><td>5962</td></tr> <tr><td>5921</td><td>5963</td></tr> <tr><td>5923</td><td>5964</td></tr> <tr><td>5940</td><td>5955</td></tr> <tr><td>5947</td><td>5967</td></tr> </table>	5906	5952	5910	5962	5921	5963	5923	5964	5940	5955	5947	5967
2361	2104																																					
2366	2399																																					
2405	2216																																					
2902	2420																																					
2388	2438																																					
2398	2223																																					
1205	2140																																					
2224	1225																																					
2105	2512																																					
2286	2204																																					
2117	2347																																					
1223	2107																																					
5906	5952																																					
5910	5962																																					
5921	5963																																					
5923	5964																																					
5940	5955																																					
5947	5967																																					
<p style="text-align: center;"><b>PD-124</b></p> <p style="text-align: center;"><u>PARTS LISTING</u></p> <table style="width: 100%; border: none;"> <tr><td>5902</td><td>5924</td></tr> <tr><td>5903</td><td>5925</td></tr> <tr><td>5908</td><td>5931</td></tr> <tr><td>5917</td><td>5941</td></tr> <tr><td>5920</td><td>5948</td></tr> <tr><td>5922</td><td>5961</td></tr> </table>	5902	5924	5903	5925	5908	5931	5917	5941	5920	5948	5922	5961	<p style="text-align: center;"><b>PD-125</b></p> <p style="text-align: center;"><u>PARTS LISTING</u></p> <table style="width: 100%; border: none;"> <tr><td>625</td><td>2226</td></tr> <tr><td>671</td><td>2227</td></tr> <tr><td>672</td><td>2484</td></tr> <tr><td>2222</td><td>2193</td></tr> <tr><td>2259</td><td>2322</td></tr> <tr><td>2225</td><td>2423</td></tr> </table>	625	2226	671	2227	672	2484	2222	2193	2259	2322	2225	2423	<p style="text-align: center;"><b>PD-126</b></p> <p style="text-align: center;"><u>PARTS LISTING</u></p> <table style="width: 100%; border: none;"> <tr><td>2121</td><td>2353</td></tr> <tr><td>2122</td><td>2354</td></tr> <tr><td>2123</td><td>2480</td></tr> <tr><td>2452</td><td>2292</td></tr> <tr><td>2321</td><td>2330</td></tr> </table>	2121	2353	2122	2354	2123	2480	2452	2292	2321	2330		
5902	5924																																					
5903	5925																																					
5908	5931																																					
5917	5941																																					
5920	5948																																					
5922	5961																																					
625	2226																																					
671	2227																																					
672	2484																																					
2222	2193																																					
2259	2322																																					
2225	2423																																					
2121	2353																																					
2122	2354																																					
2123	2480																																					
2452	2292																																					
2321	2330																																					
<p style="text-align: center;"><b>PD-127</b></p> <p style="text-align: center;"><u>PARTS LISTING</u></p> <table style="width: 100%; border: none;"> <tr><td>2366</td><td>2893</td></tr> <tr><td>2370</td><td>2492</td></tr> <tr><td>2375</td><td>2523</td></tr> <tr><td>2379</td><td>2493</td></tr> <tr><td>2416</td><td>2495</td></tr> <tr><td>2417</td><td>2496</td></tr> </table>	2366	2893	2370	2492	2375	2523	2379	2493	2416	2495	2417	2496	<p style="text-align: center;"><b>PD-128</b></p> <p style="text-align: center;"><u>PARTS LISTING</u></p> <table style="width: 100%; border: none;"> <tr><td>2211</td><td>2374</td></tr> <tr><td>2248</td><td>2473</td></tr> <tr><td>2381</td><td>2494</td></tr> <tr><td>2236</td><td>2502</td></tr> <tr><td>2503</td><td>2387</td></tr> <tr><td>2277</td><td>2440</td></tr> </table>	2211	2374	2248	2473	2381	2494	2236	2502	2503	2387	2277	2440	<p style="text-align: center;"><b>PD-129</b></p> <p style="text-align: center;"><u>PARTS LISTING</u></p> <table style="width: 100%; border: none;"> <tr><td>2278</td><td>2236</td></tr> <tr><td>2379</td><td>2339</td></tr> <tr><td>2492</td><td>2503</td></tr> <tr><td>2361</td><td>2277</td></tr> <tr><td>2477</td><td>2374</td></tr> <tr><td>2491</td><td>2502</td></tr> </table>	2278	2236	2379	2339	2492	2503	2361	2277	2477	2374	2491	2502
2366	2893																																					
2370	2492																																					
2375	2523																																					
2379	2493																																					
2416	2495																																					
2417	2496																																					
2211	2374																																					
2248	2473																																					
2381	2494																																					
2236	2502																																					
2503	2387																																					
2277	2440																																					
2278	2236																																					
2379	2339																																					
2492	2503																																					
2361	2277																																					
2477	2374																																					
2491	2502																																					
<p style="text-align: center;"><b>PD-130</b></p> <p style="text-align: center;"><u>PARTS LISTING</u></p> <table style="width: 100%; border: none;"> <tr><td>2236</td><td>2478</td></tr> <tr><td>2339</td><td>2491</td></tr> <tr><td>2503</td><td>2548</td></tr> <tr><td>2373</td><td>2549</td></tr> <tr><td>2379</td><td>2374</td></tr> <tr><td>2475</td><td>2502</td></tr> </table>	2236	2478	2339	2491	2503	2548	2373	2549	2379	2374	2475	2502	<p style="text-align: center;"><b>PD-131</b></p> <p style="text-align: center;"><u>PARTS LISTING</u></p> <table style="width: 100%; border: none;"> <tr><td>194</td><td>2057</td></tr> <tr><td>194NA</td><td>2057NA</td></tr> <tr><td>1156</td><td>3057</td></tr> <tr><td>1156NA</td><td>3057NA</td></tr> <tr><td>1157</td><td>3157</td></tr> <tr><td>1157NA</td><td>3157NA</td></tr> </table>	194	2057	194NA	2057NA	1156	3057	1156NA	3057NA	1157	3157	1157NA	3157NA	<p style="text-align: center;"><b>PD-132</b></p> <p style="text-align: center;"><u>PARTS LISTING</u></p> <table style="width: 100%; border: none;"> <tr><td>2147</td><td>2723</td></tr> <tr><td>2702</td><td>2724</td></tr> <tr><td>2722</td><td>2725</td></tr> </table>	2147	2723	2702	2724	2722	2725						
2236	2478																																					
2339	2491																																					
2503	2548																																					
2373	2549																																					
2379	2374																																					
2475	2502																																					
194	2057																																					
194NA	2057NA																																					
1156	3057																																					
1156NA	3057NA																																					
1157	3157																																					
1157NA	3157NA																																					
2147	2723																																					
2702	2724																																					
2722	2725																																					
<p style="text-align: center;"><b>PD-133</b></p> <p style="text-align: center;"><u>PARTS LISTING</u></p> <table style="width: 100%; border: none;"> <tr><td>3035</td><td>3108</td></tr> <tr><td>3036</td><td>3276</td></tr> <tr><td>3042</td><td>3279</td></tr> <tr><td>3043</td><td>3280</td></tr> <tr><td>3044</td><td>3282</td></tr> <tr><td>3049</td><td>3286</td></tr> </table>	3035	3108	3036	3276	3042	3279	3043	3280	3044	3282	3049	3286																										
3035	3108																																					
3036	3276																																					
3042	3279																																					
3043	3280																																					
3044	3282																																					
3049	3286																																					













# PLASTIC DISPENSER ASSORTMENTS

(PLASTIC BOX-11" X 6-3/4" X 1-3/4")













**PD-121**  
PLASTIC DRIVE RIVET / EXPANSION SCREW

<p>2361</p>  <p>EXPANSION SCREW RIVET INNER FENDER SHIELD NISSAN &amp; UNIVERSAL</p>	<p>2366</p>  <p>EXPANSION SCREW RIVET PANEL RETAINER 6 MM HOLE; 15.2 MM FLANGE TOYOTA</p>	<p>2405</p>  <p>PLASTIC SCREW RIVET FASCIA/GRILLE 6 MM HOLE DIAMETER FORD-'85 &amp; UP</p>	<p>2902</p>  <p>NYLON PUSH-RIVET WHEEL OPENING, COWL VENT FORD, SATURN</p>	<p>2388</p>  <p>DRIVE RIVET-BUMPER FASCIA GENERAL USE GM, FORD</p>	<p>2398</p>  <p>PLASTIC DRIVE RIVET 6.3 MM HOLE SIZE GM, FORD, AMC &amp; CHRYSLER</p>
<p>2104</p>  <p>PLASTIC RIVET-GRILLE TO HEADLAMP BRACKET 1/4" HOLE; FORD &amp; UNIVERSAL</p>	<p>2399</p>  <p>PLASTIC DRIVE RIVET 8 MM HOLE SIZE GM, FORD, CHRYSLER</p>	<p>2216</p>  <p>PLASTIC RIVET-MUD SKIRT ATTACHING, OTHER USES ALSO GM 'X' &amp; 'F' CARS-'81 &amp; UP</p>	<p>2420</p>  <p>PUSH TYPE RIVET-8 MM HOLE SIZE GM, FORD</p>	<p>2438</p>  <p>PUSH TYPE BUMPER FASCIA RIVET 9.5 MM HOLE SIZE GM, '87 &amp; UP</p>	<p>2223</p>  <p>PLASTIC RIVET-BLACK FRONT &amp; REAR BUMPER ATTACHING STRIP 1/8" SHI &amp; UP</p>













**PD-122**  
CHRISTMAS TREE AND SCREW NAIL ASSORTMENT

<p>1205</p>  <p>DOOR TRIM PANEL FASTENER NYLON; GM PRODUCTS-'71 &amp; UP</p>	<p>2224</p>  <p>DOOR TRIM TO INNER PANEL FASTENER GM-'77 TO '82</p>	<p>2105</p>  <p>RETAINER-INTERIOR DOOR TRIM PANEL NYLON, AMC, GM, FORD, CHRYSLER, VW</p>	<p>2286</p>  <p>RETAINER-CONDUIT TO SHEET METAL IN DOORS NYLON, GM 'C" BODY</p>	<p>2117</p>  <p>TRIM PANEL FASTENER GM &amp; FORD-'76 &amp; UP</p>	<p>1223</p>  <p>RETAINER-UNIVERSAL TRIM &amp; PANEL CLIP UPPER GRILLE-1/4" HOLE SIZE CHRYSLER</p>
<p>2140</p>  <p>SCREW NAIL RETAINER-BLACK 1/4" HOLE GM, CHRYSLER, FORD, AMC</p>	<p>1225</p>  <p>SCREW NAIL RETAINER-BLACK GM, AMC &amp; UNIVERSAL</p>	<p>2512</p>  <p>DOOR PANEL CLIP GM-'80 &amp; UP</p>	<p>2204</p>  <p>PANEL FASTENER-RADIATOR SKIRT ATTACHING CADILLAC &amp; GM</p>	<p>2347</p>  <p>INTERIOR TRIM CLIP-BLACK 7MM HOLE; 20MM HEAD 30MM GRIP RANGE GM, FORD &amp; UNIVERSAL</p>	<p>2107</p>  <p>INTERIOR TRIM RETAINER GM &amp; UNIVERSAL</p>













**PD-123**  
METRIC BODY BOLT ASSORTMENT

<p>5906</p>  <p>8 MM X 25 MM BODY BOLT HEX WASHER HEAD, CA POINT 17 MM WASHER O.D. GM &amp; UNIVERSAL-'77 &amp; UP</p>	<p>5910</p>  <p>8 MM X 30 MM BODY BOLT INDENTED HEX HEAD W/ 24MM LSE WSHR CA POINT GM &amp; UNIVERSAL</p>	<p>5921</p>  <p>6 MM X 25 MM BODY BOLT INDENTED HEX HEAD W/ 24MM LSE WSHR CA POINT GM &amp; UNIVERSAL</p>	<p>5923</p>  <p>6 MM X 25 MM BODY BOLT INDENTED HEX HEAD W/ 17 MM LSE WSHR CA POINT (SMALLER WASHER THAN 5921)</p>	<p>5940</p>  <p>6 MM X 20 MM BODY BOLT INDENTED HEX HEAD WITH LOOSE WASHER DOG POINT</p>	<p>5947</p>  <p>6 MM X 20 MM BODY BOLT INDENTED HEX HEAD WITH 17 MM LOOSE WASHER GM &amp; UNIVERSAL</p>
<p>5952</p>  <p>6 MM X 28 MM BODY BOLT INDENTED HEX HEAD (8 MM HEX) WITH 19 MM LOOSE WASHER CA POINT FORD</p>	<p>5962</p>  <p>6 X 35 MM BODY BOLT INDENTED HEX HEAD 17 MM WASHER CA POINT GM &amp; UNIVERSAL</p>	<p>5963</p>  <p>6 X 22 MM BODY BOLT IND. HEX HEAD 19 MM (3/4") WSHR DOG POINT FORD, CHRYSLER &amp; UNIVERSAL</p>	<p>5964</p>  <p>8 MM X 20 MM HEX WASHER HEAD BODY BOLT-CA PT. GM &amp; UNIVERSAL-'77 &amp; UP</p>	<p>5955</p>  <p>8 MM X 35 MM BODY BOLT INDENTED HEX HEAD WITH 24 MM LOOSE WASHER CA POINT-BLACK</p>	<p>5967</p>  <p>8 MM X 20 MM HEX WASHER HEAD BODY BOLT-CA PT. 10 MM HEX, 15 MM WASHER GM &amp; UNIVERSAL-'77 &amp; UP</p>













**PD-124**  
METRIC SPEED, "KEPS" NUT & RETAINER ASSORTMENT

<p>5902</p>  <p>8 MM METRIC FOLDOVER NUT GM &amp; UNIVERSAL</p>	<p>5903</p>  <p>8 MM LONG THROAT METRIC FOLDOVER NUT GM-'77 &amp; UP, UNIVERSAL</p>	<p>5908</p>  <p>8 MM NUT WITH FREE SPINNING 24 MM WASHER CHRYSLER, GM &amp; UNIVERSAL GM-'77 &amp; UP</p>	<p>5917</p>  <p>8 MM PUSH NUT BOLT RETAINER 16 MM OUTSIDE DIAMETER</p>	<p>5920</p>  <p>6 MM METRIC SPEED NUT GM-'79 &amp; UP FORD &amp; UNIVERSAL</p>	<p>5922</p>  <p>6 MM NUT WITH FREE SPINNING 16MM TOOTHED WASHER 10 MM HEX, PHOS &amp; OIL VW, GM-'79 &amp; UP</p>
<p>5924</p>  <p>6 MM METRIC SPEED NUT LONG THROAT GM-'X' &amp; 'J' CARS &amp; UNIVERSAL</p>	<p>5925</p>  <p>8 MM PUSH NUT BOLT RETAINER 24 MM OUTSIDE DIAMETER</p>	<p>5931</p>  <p>8 MM HEX FLANGE NUT CHRYSLER, GM &amp; UNIVERSAL BLACK</p>	<p>5941</p>  <p>6 MM HEX FLANGE NUT 10 MM HEX SERRATED-BLACK</p>	<p>5948</p>  <p>6 MM NUT WITH FREE SPINNING 19MM WASHER 10 MM HEX, PHOS &amp; OIL GM &amp; CHRYSLER</p>	<p>5961</p>  <p>6 MM PUSH NUT BOLT RETAINER 17 MM OUTSIDE DIAMETER</p>

**PD-125**  
SPECIAL AUTOBODY SHEET METAL SCREWS ASSORTMENT

<p>625</p>  <p>#8 X 3/8" (#6 HEAD) (3/8" WASHER DIAMETER) PHILLIPS OVAL WASHER HD SELF TAPPING SCREW-PLATED WHEEL OPENING MOULDING SCREW</p>	<p>671</p>  <p>5-20 X 3/8" (7/32" HEAD) PHILLIPS FLAT HD SCREW-PLATED USE WITH PLASTIC MOLDING CLIPS, LANDAU CLIPS (W&amp;E #345) UNIVERSAL</p>	<p>672</p>  <p>#8 X 3/8" SCREW FOR ATTACHING WINDSHIELD &amp; REAR WINDOW REVEAL MOLDING CLIPS (LOW PROFILE HEAD) CHRYSLER &amp; UNIVERSAL-BRIGHT</p>	<p>2222</p>  <p>#8 X 1/2" (3/8" WSHR DIAM.) PHILLIPS OVAL WASHER HD SELF DRILLING SCREW-PLATED WHEEL OPENING MOULDING SCREW GM &amp; UNIVERSAL</p>	<p>2259</p>  <p>4.2 X 12 MM (#8 X 1/2") (25/64" WASHER DIAMETER) PHILLIPS OVAL WASHER HD SCREW-CHROME</p>	<p>2225</p>  <p>PHILLIPS FLAT WASHER HD. SCREW-POZIDRIVE 4.2MM X 10MM (7/16" WASHER)-BLACK</p>
<p>2226</p>  <p>PHILLIPS FLAT WASHER HEAD SCREW 4.2MM X 20MM-POZIDRIVE (7/16" WASHER) GM &amp; UNIVERSAL-BLACK</p>	<p>2227</p>  <p>PHILLIPS ROUND WASHER HEAD SCREW 4.2MM X 13MM-POZIDRIVE (21/64" WASHER) GM, FORD &amp; UNIVERSAL-BLACK</p>	<p>2484</p>  <p>4.2 X 20 MM PHILLIPS OVAL HEAD SEMS SCREWS FLUSH TYPE WASHER-SELF DRILLING</p>	<p>2193</p>  <p>4.2-1.41X20MM UNSLOTTED-IND. HEX HD SCREW WITH 16MM LSE WSHR 7MM HEX) GM &amp; UNIVERSAL</p>	<p>2322</p>  <p>4.2-1.41X20MM UNSLOTTED HEX HD SCREW (12 MM LOOSE WASHER) GM-BLACK</p>	<p>2423</p>  <p>6.3 X 20MM HEX WASHER HEAD SCREW WITH 16MM LOOSE WASHER (10MM HEX) GM PRODUCTS.</p>

**PD-126**  
SPECIAL AUTOMOTIVE RIVETS ASSORTMENT

<p>2121</p>  <p>SUPER SPLIT WINDOW REGULATOR RIVET 1/4" DIAMETER .30-.140 GRIP 257-.261 HOLE REQUIRED GM, FORD, CHRYSLER-'76&amp;UP</p>	<p>2121</p>  <p>SUPER SPLIT WINDOW REGULATOR RIVET 1/4" DIAMETER .30-.140 GRIP 257-.261 HOLE REQUIRED GM, FORD, CHRYSLER-'76&amp;UP</p>	<p>2122</p>  <p>SUPER-SPLIT "GLASS STOP" RIVET 1/4" DIAM. .52-.59 GRIP RANGE 257-.261 HOLE REQUIRED FORD, CHRYSLER-'76&amp;UP</p>	<p>2122</p>  <p>SUPER-SPLIT "GLASS STOP" RIVET 1/4" DIAM. .52-.59 GRIP RANGE 257-.261 HOLE REQUIRED FORD, CHRYSLER-'76&amp;UP</p>	<p>2123</p>  <p>SUPER-SPLIT OUTSIDE DOOR HANDLE RIVET-1/4" DIAM. .090-.115" GRIP REQUIRED FORD, LINCOLN/ MERC.-'78&amp;UP</p>	<p>2452</p>  <p>DOOR HANDLE RIVET PEEL TYPE-1/4" DIAMETER ZINC &amp; BLACK PHOS. FORD</p>
<p>2321</p>  <p>5/32" ALUMINUM RIVET/ STEEL MANDREL COUNTERSUNK HEAD TRUNK LOCK-SEALED END SWIVEL EMBLEM</p>	<p>2330</p>  <p>1/4" RIVET 1/2" FLANGE FORD STEEL BUMPER RIVET YELLOW ZINC DICHROMATE</p>	<p>2353</p>  <p>1/4" RIVET BUMPER ASSEMBLY .125-.250" GRIP BLACK PHOS. FORD-'81 &amp; UP</p>	<p>2354</p>  <p>3/16" RIVET GRILLE RETAINING 3/8"-1/2" GRIP (LARGE FLANGE-9/16") BLACK PHOS. FORD-'79 &amp; UP</p>	<p>2480</p>  <p>3/16" RIVET ALL ALUMINUM SCUFF PLATE TO SILL .078-.236 GRIP BLACK FORD, LINCOLN-'89 &amp; UP</p>	<p>2688</p>  <p>1/8" ALL ALUMINUM RIVET-FOR WINDSHIELD SIDE RAIL 3/8" FLANGE DIAMETER .053-.125 GRIP RANGE FORD-'89 &amp; UP BLACK</p>

# PLASTIC DISPENSER ASSORTMENTS

(PLASTIC BOX-11" X 6-3/4" X 1-3/4")

<b>PD-127</b> <b>TOYOTA-TRIM CLIPS, SCREW RIVETS</b> <b>ASSORTMENT</b>					
<b>2366</b>  EXPANSION SCREW RIVET PANEL RETAINER 6MM HOLE, 15.2MM FLANGE TOYOTA	<b>2370</b>  GRILLE CLIP TOYOTA	<b>2375</b>  DOOR PANEL FASTENER TOYOTA, MAZDA, ISUZU GM-NOVA-'85	<b>2379</b>  WEATHERSTRIP & TRIM PANEL CLIP NISSAN, TOYOTA, HONDA	<b>2416</b>  RETAINER-INTERIOR DOOR TRIM '88 TOYOTA CAMRY	<b>2417</b>  RETAINER-INTERIOR DOOR TRIM '88 TOYOTA CAMRY
<b>2893</b>  DOOR TRIM PANEL RETAINER TOYOTA (AVALON & CAMRY) '93 & UP	<b>2492</b>  INTERIOR PANEL FASTENER ISUZU, NISSAN, TOYOTA, MAZDA	<b>2523</b>  PANEL RETAINER TOYOTA	<b>2493</b>  HOOD INSULATION CLIP (30MM HEAD DIAM.; 7MM HOLE) TOYOTA	<b>2495</b>  BLACK NYLON "U" NUT FENDER, WHEELHOUSE TOYOTA	<b>2496</b>  BLACK NYLON "U" NUT FENDER, WHEELHOUSE TOYOTA

<b>PD-128</b> <b>TOYOTA GROMMETS, RETAINERS</b> <b>ASSORTMENT</b>					
<b>2211</b>  HEADLAMP ADJUSTING SCREW- 6 MM	<b>2248</b>  HEADLAMP ADJUSTING NUT TOYOTA & MITSUBISHI	<b>2381</b>  GRILLE NUT/ GROMMET TOYOTA, MAZDA, MITSUBISHI GM-NOVA '85	<b>2236</b>  NUT- SIDE LAMP MARKER- PLASTIC TOYOTA, NISSAN, HONDA, MAZDA, MITSUBISHI AND UNIVERSAL	<b>2503</b>  NYLON SCREW GROMMET MAZDA, HONDA, NISSAN AND TOYOTA	<b>2277</b>  (PLASTIC GROMMET NUT SCREW ANCHOR TOYOTA, NISSAN, MITSUBISHI)
<b>2374</b>  PLASTIC SCREW GROMMET HONDA, TOYOTA, NISSAN, MAZDA	<b>2473</b>  SCREW GROMMET 7.8 MM HOLE, 14 MM HEAD DIAMETER, 16 MM OVERALL LENGTH TOYOTA	<b>2494</b>  PLASTIC GROMMET FENDER SHIELD 6 MM SCREW SIZE 20 MM HEAD 8 X 8 MM HOLE TOYOTA	<b>2502</b>  NYLON SCREW GROMMET-MAZDA, NISSAN, MIT., TOYOTA	<b>2387</b>  BUMPER CUSHION RETAINER TOYOTA-'82 & UP	<b>2440</b>  BUMPER STRIP RETAINER (STAINLESS STEEL) TOYOTA

<b>PD-129</b> <b>NISSAN GROMMETS AND RETAINER</b> <b>ASSORTMENT</b>					
<b>2278</b>  TRIM PANEL RETAINER BLACK PLASTIC TOYOTA & DATSUN	<b>2379</b>  WEATHERSTRIP & TRIM PANEL CLIP NISSAN, TOYOTA, HONDA	<b>2492</b>  INTERIOR PANEL FASTENER ISUZU, NISSAN, TOYOTA, MAZDA	<b>2361</b>  EXPANSION SCREW RIVET INNER FENDER SHIELD NISSAN & UNIVERSAL	<b>2477</b>  BUMPER FASCIA RETAINER 22 MM HD DIAM. 11 MM SHOULDER DIAM. 2-10 MM P.R. 8 MM HOLE SIZE NISSAN-'86 & UP	<b>2491</b>  NYLON SCREW RIVET 20 MM HEAD 8 MM HOLE HONDA, NISSAN, MAZDA
<b>2236</b>  NUT- SIDE LAMP MARKER- PLASTIC TOYOTA, NISSAN, HONDA, MAZDA, MITSUBISHI AND UNIVERSAL	<b>2339</b>  PLASTIC NUT GENERAL USAGE NISSAN, HONDA, MAZDA	<b>2503</b>  NYLON SCREW GROMMET MAZDA, HONDA, NISSAN AND TOYOTA	<b>2277</b>  (PLASTIC GROMMET NUT SCREW ANCHOR TOYOTA, NISSAN, MITSUBISHI)	<b>2374</b>  PLASTIC SCREW GROMMET HONDA, TOYOTA, NISSAN, MAZDA	<b>2502</b>  NYLON SCREW GROMMET-MAZDA, NISSAN, HONDA, MIT., TOYOTA

<b>PD-130</b> <b>HONDA-GROMMETS AND RETAINER</b> <b>ASSORTMENT</b>					
<b>2236</b>  NUT- SIDE LAMP MARKER- PLASTIC TOYOTA, NISSAN, HONDA, MAZDA, MITSUBISHI AND UNIVERSAL	<b>2339</b>  PLASTIC NUT GENERAL USAGE NISSAN, HONDA, MAZDA	<b>2503</b>  NYLON SCREW GROMMET MAZDA, HONDA, NISSAN AND TOYOTA	<b>2373</b>  INTERIOR PANEL FASTENER HONDA	<b>2379</b>  WEATHERSTRIP & TRIM PANEL CLIP NISSAN, TOYOTA, HONDA	<b>2475</b>  PLASTIC SCREW RIVET (6MM FLANGE DIAMETER) (2-6MM PANEL RANGE) HONDA
<b>2478</b>  PLASTIC DRIVE RIVET 12 X 18MM HEAD 2MM SHOULDER 8MM HOLE HONDA	<b>2491</b>  NYLON SCREW RIVET 20 MM HEAD 8 MM HOLE HONDA, NISSAN, MAZDA	<b>2549</b>  SCREW RIVET- BUMPER FASCIA 10MM HOLE 20 MM HD DIAM. 27 MM STEM HONDA-'90 & UP	<b>2548</b>  SCREW RIVET- BUMPER FASCIA 10MM HOLE 20 MM HD DIAM. HONDA-'90 & UP	<b>2374</b>  PLASTIC SCREW GROMMET NISSAN, MAZDA	<b>2502</b>  NYLON SCREW GROMMET-MAZDA, NISSAN, HONDA, MIT., TOYOTA

<b>PD-131</b> <b>MINIATURE BULB</b> <b>ASSORTMENT</b>					
<b>194</b>  SIDE MARKER, INSTRUMENT, LICENSE PLATE	<b>194NA</b>  AMBER SIDE MARKER, INSTRUMENT, LICENSE PLATE	<b>1156</b>  SIGNAL, TAIL, STOP PARKING	<b>1156NA</b>  AMBER SIGNAL, TAIL, STOP PARKING	<b>1157</b>  SIGNAL, TAIL, STOP PARKING	<b>1157NA</b>  AMBER SIGNAL, TAIL, STOP PARKING
<b>2057</b>  SIGNAL, TAIL, STOP PARKING	<b>2057NA</b>  AMBER SIGNAL, TAIL, STOP PARKING	<b>3057</b>  SIGNAL, TAIL, STOP BACKUP	<b>3057NA</b>  AMBER SIGNAL, TAIL, STOP PARKING	<b>3157</b>  SIDE MARKER, SIGNAL, TAIL, STOP	<b>3157NA</b>  AMBER SIDE MARKER, SIGNAL, TAIL, STOP

<b>PD-132</b> <b>HOLE PLUG ASSORTMENT</b>					
<b>2147</b>  BUTTON PLUG FOR 1/2" HOLES. RECESSED HEAD HOLDS ON METAL. THICKNESS RANGE FROM .06-.13". ALSO PLUGS HOLES EASILY WHERE METAL THICKNESS IS INCREASED OR IRREGULAR, OR ON CORNER BENDS. USE WHEN RUST-PROOFING.	<b>2702</b>  BUTTON PLUG FOR 3/4" HOLES. RECESSED HEAD HOLDS ON METAL. THICKNESS RANGE FROM .02-.14". ALSO PLUGS HOLES EASILY WHERE METAL THICKNESS IS INCREASED OR IRREGULAR, OR ON CORNER BENDS. USE WHEN RUST-PROOFING.	<b>2722</b>  FLUSH TYPE HOLE PLUG. USED FOR PAINTLESS DENT REMOVAL AND RUST-PROOFING. HOLE SIZE-1/4" PANEL RANGE-.02-.07	<b>2723</b>  FLUSH TYPE HOLE PLUG. USED FOR PAINTLESS DENT REMOVAL AND RUST-PROOFING. HOLE SIZE-3/8" PANEL RANGE-.02-.05	<b>2724</b>  FLUSH TYPE HOLE PLUG. USED FOR PAINTLESS DENT REMOVAL AND RUST-PROOFING. HOLE SIZE-1/2" PANEL RANGE-.03-.08	<b>2725</b>  FLUSH TYPE HOLE PLUG. USED FOR PAINTLESS DENT REMOVAL AND RUST-PROOFING. HOLE SIZE-3/4" PANEL RANGE-.05-.11

<b>PD-133</b> <b>GM ROCKER PANEL MOULDING CLIP</b> <b>ASSORTMENT</b>					
<b>3035</b>  (11518357) ROCKER PANEL MOULDING CLIP WITH SEALER 9 MM HOLE SIZE TOP HD- 14 X 20 MM OVERALL HT-20 MM	<b>3036</b>  (25722671) ROCKER PANEL MOULDING CLIP WIDTH-78"	<b>3042</b>  (10423553) ROCKER PANEL MOULDING CLIP 8 MM HOLE SIZE TOP HD- 12 X 20 MM OVERALL HT-21 MM	<b>3043</b>  (25724529) ROCKER PANEL MOULDING CLIP 8 MM HOLE SIZE TOP HD- 14 X 20 MM OVERALL HT-29 MM	<b>3044</b>  (22603384) ROCKER PANEL MOULDING CLIP 8 MM HOLE SIZE TOP HD- 19 X 26 MM HEIGHT-22.4MM	<b>3049</b>  (10411336, 10431761) ROCKER PANEL MOULDING CLIP 7/16" HOLE SIZE TOP HD- 11/16X1-1/2" HEIGHT-1.3764"
<b>3108</b>  (25693852) ROCKER PANEL MOULDING CLIP 9 MM HOLE SIZE TOP HD- 14 X 20 MM OVERALL HT-20 MM	<b>3276</b>  (10323057) ROCKER PANEL MOULDING CLIP 9 MM HOLE SIZE TOP HD- 12 X 20 MM LENGTH-20 MM	<b>3279</b>  (10297370) ROCKER PANEL MOULDING CLIP 9 MM HOLE SIZE TOP HD- 12 X 20 MM LENGTH-20 MM	<b>3280</b>  (11518088) ROCKER PANEL MOULDING CLIP WITH SEALER 9 MM HOLE SIZE TOP HD- 12 X 21 MM LENGTH-28 MM	<b>3282</b>  (15872008) ROCKER PANEL MOULDING CLIP WITH SEALER 15 MM HOLE SIZE TOP HD- 20 X 30 MM LENGTH-28 MM	<b>3286</b>  (11609923) ROCKER PANEL MOULDING CLIP WITH SEALER 9 MM HOLE SIZE TOP HD- 12 X 20 MM OVERALL HT-21 MM

## PLASTIC PAK ASSORTMENTS

<b>AF-100</b> <b>BLADE TYPE FUSE</b> <b>ASSORTMENT</b>		
<b>2540</b> (5 AMP)	<b>2541</b> (10 AMP)	<b>2542</b> (15 AMP)
<b>2543</b> (20 AMP)	<b>2544</b> (25 AMP)	<b>2545</b> (30 AMP)
100 BLADE TYPE FUSES PACKED IN A HANG-UP PLASTIC BOX		

<b>BUS-24</b> <b>DOOR HINGE BUSHING</b> <b>ASSORTMENT</b>	
<b>2281</b>	<b>2282</b>
<b>2283</b>	<b>2284</b>

<b>CFS-40</b> <b>COWL- HOOD- FENDER SHIM</b> <b>ASSORTMENT</b>	
<b>965</b> BODY SHIMS 1/16" THICK	<b>966</b> BODY SHIMS 1/8" THICK
<b>970</b> BODY SHIMS 1/16" THICK	<b>972</b> BODY SHIMS 3/16" THICK

<b>CNA-145</b> <b>CLIP NUT ASSORTMENT</b>		
<b>846</b> #8 SCREW SIZE	<b>852</b> #8 SCREW SIZE	<b>853</b> #8 SCREW SIZE
<b>2346</b> #6 SCREW SIZE	<b>858</b> #10 SCREW SIZE	<b>859</b> #10 SCREW SIZE

<b>AFA-12</b> <b>BLADE TYPE FUSE</b> <b>ASSORTMENT-(24 FUSES)</b>		
<b>2540</b> (5 AMP)	<b>2541</b> (10 AMP)	<b>2542</b> (15 AMP)
<b>2543</b> (20 AMP)	<b>2544</b> (25 AMP)	<b>2545</b> (30 AMP)











<b>CPN-250</b> <b>COTTER PIN ASSORTMENT</b>	
<b>2167</b> 1/16" X 1"	<b>2169</b> 1/8" X 1-1/2"
<b>2168</b> 3/32" X 1"	<b>2171</b> 5/32" X 1-1/2"

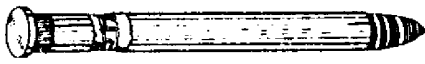

















<b>CNA-102</b> <b>CLIP NUT ASSORTMENT</b>	
<b>853</b> FENDER CLIP- FRONT END #8A SCREW	<b>2164</b> "U" TYPE CLIP- #10A SCREW
<b>860</b> FRONT END CLIP- #14A SCREW	<b>814</b> "U" TYPE CLIP- #14 SCREW







<b>DRC-300</b> <b>DOOR LOCK ROD END</b> <b>CLIP ASSORTMENT</b>		
<b>2505</b> DOOR LOCK CLIP R.H.	<b>2506</b> DOOR LOCK CLIP-L.H.	<b>2507</b> DOOR LOCK CLIP-R.H.
<b>2508</b> DOOR LOCK CLIP L.H.	<b>2509</b> DOOR LOCK CLIP R.H.	<b>2510</b> DOOR LOCK CLIP-L.H.



## PLASTIC PAK ASSORTMENTS

 <b>HPB-9</b> <b>DOOR HINGE PIN AND BUSHING ASSORTMENT</b> 			
<b>2357</b> 	<b>2358</b> 		
<b>2359</b> 	<b>2360</b> 	<b>2327</b> 	
<b>2281</b> 	<b>2282</b> 	<b>2283</b> 	<b>2284</b> 

 <b>HPB-17</b> <b>DOOR HINGE PIN AND BUSHING ASSORTMENT</b> 					
<b>2357</b> 	<b>2360</b> 				
<b>2358</b> 	<b>2635</b> 				
<b>2359</b> 	<b>2281</b> 	<b>2282</b> 	<b>2283</b> 	<b>2284</b> 	<b>2638</b> 
<b>2327</b> 	<b>2457</b> 	<b>2600</b> 	<b>2639</b> 		
				<b>2646</b> 	<b>2638</b> 

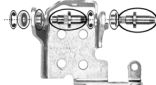



<b>GMT-25 GM TRUCKS DOOR HINGE AND BUSHING ASSORTMENT</b>			
<b>2714</b> 	<b>2753</b> 		
<b>2896</b> 	<b>2740</b> 	<b>2648</b> 	
<b>2741</b> 	<b>3070</b> 		

# PLASTIC PAK ASSORTMENTS



## ECA-130

### "E" CLIP ASSORTMENT







<b>2646</b> 1/4" SHAFT DIAM.		<b>2645</b> 3/16" SHAFT DIAM.	
<b>2648</b> 3/8" SHAFT DIAM		<b>2647</b> 5/16" SHAFT DIAM.	



## VTC-50

### VACUUM TEE AND CAP ASSORTMENT







<b>2426</b>  (357020) (6272766) (22508050) (373846-S) (3671410) (3673945) 3/16" X 3/16" X 3/16" THREE WAY VACUUM TEE GM, FORD, CHRYSLER & UNIVERSAL	<b>2427</b>  (560625) (22508051) (383003) (389138) (4104998) 3/16" X 3/16" CONNECTOR GM, FORD, CHRYSLER & UNIVERSAL	<b>2430</b>  (14017705) (3895904) (3751212) 1/8" X 1/8" X 1/8" THREE WAY VACUUM TEE GM, FORD, CHRYSLER & UNIVERSAL	<b>2431</b>  1/4" X 1/4" X 1/4" THREE WAY VACUUM TEE GM & UNIVERSAL	<b>2428</b>  3/16" VACUUM CAP GM, FORD, CHRYSLER AND UNIVERSAL	<b>2988</b>  1/8" VACUUM CAP GM, FORD, CHRYSLER AND UNIVERSAL
<b>2989</b>  1/4" VACUUM CAP GM, FORD, CHRYSLER AND UNIVERSAL					

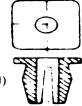

## HLN 75





### HEADLAMP AND OTHER USE-PLASTIC & NYLON NUTS

<b>815</b> HEADLAMP DOOR RETAINING NUT (NYLON)		<b>819</b> GRILLE NUT —NYLON 1/4" HOLE #8-10SCR	
<b>825</b> HEADLAMP & LICENSE PLATE PLASTIC NUT		<b>832</b> PLASTIC HEADLAMP DOOR UPPER RETAINER	

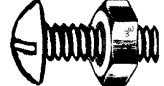
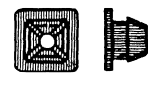

## LPN-46





### LICENSE PLATE NUT & SCREW ASSORTMENT

<b>963</b>  1/4-20 X 1/2" SLOTTED TRUSS HEAD WITH HEX NUT	<b>818</b>  LICENSE PLATE NUT USE #14 SCREW	<b>2203</b>  1/4 X 3/4" HEX WSHR HEAD - SLOTTED
<b>826</b>  LICENSE PLATE NUT USE #14 SCREW	<b>537</b>  1/4 X 3/4" SLOTTED PAN HEAD SCREW	<b>2295</b>  LICENSE PLATE NUT- USE #14 SCREW



## MET-501

### METRIC THREAD CUTTING NUTS ASSORTMENT

<b>5990</b> 3.2 MM		<b>5913</b> 4 MM	
<b>5914</b> 5 MM		<b>5915</b> 6.3 MM	

**"METRIC CONVERSION TABLE"**





Millimeter/Decimal/Fractional Equivalents

METRIC	DEC.	FRACT.	METRIC	DEC.	FRACT.	METRIC	DEC.	FRACT.
0.3968mm	.0156"	1/64"	13mm	.5118"		29mm	1.1417"	
0.7924	.0312	1/32	14	.5512		30	1.1811	
1	.0394		14.2875	.5625	9/16"	35	1.3779	
1.5875	.0625	1/16	15	.5905		38.1	1.5000	1 1/2"
2	.0787		15.8750	.625	5/8	40	1.5748	
3	.1181		16	.6299		45	1.7716	
3.175	.1250	1/8	17	.6693		50	1.9685	
4	.1575		18	.7087		50.8	2.000	2
4.7625	.1875	3/16	19	.748		55	2.1653	
5	.1968		19.05	.750	3/4	60	2.3622	
6	.2362		20	.7874		63.5	2.500	2 1/2
6.35	.2500	1/4	21	.8268		65	2.5590	
7	.2756		22	.8661		70	2.7559	
7.9375	.3125	5/16	22.23	.875	7/8	75	2.9527	
8	.3150		23	.9055		76.2	3.000	3
9	.3543		24	.9449		80	3.1496	
9.525	.375	3/8	25	.9842		85	3.3464	
10	.3937		25.4	1.0000	1	90	3.5433	
11	.4331		26	1.0236		95	3.7041	
11.1125	.4375	7/16	27	1.0630		100	3.9370	
12	.4724		28	1.1024		101.6	4.000	4
12.7	.5000	1/2						













## MET-502

### METRIC PUSH NUT BOLT RETAINER ASSORTMENT





<b>5916</b> (6.3 MM)		<b>5917</b> (8 MM)	
<b>5918</b> (10 MM)		<b>5919</b> (12 MM)	

## PLASTIC PAK ASSORTMENTS





 **MFA-50**  
MINI FUSE ASSORTMENT 

<b>2689</b> (2 AMP)  <b>2690</b> (3 AMP) 	<b>2691</b> (4 AMP)  <b>2692</b> (5 AMP) 	<b>2693</b> (7.5 AMP)  <b>2694</b> (10 AMP) 
<b>2695</b> (15 AMP)  <b>2696</b> (20 AMP) 	<b>2697</b> (25 AMP)  	<b>2698</b> (30 AMP)  





 **NT-15M**  
METRIC INSERT ASSORTMENT

<b>NT-15M-4</b>	<b>NT-15M-8</b>	<b>NT-15M-10</b>
<b>5974-</b> 4MM  <b>5942</b> 6MM 	<b>5943-</b> 8MM  	<b>5944-</b> 10 MM  





 **POCA-402**  
PUSH ON CLIPS ASSORTMENT

<b>885</b>  1/16" STUD	<b>886</b>  3/32" STUD
<b>887</b>  1/8" STUD	<b>888</b>  5/32" STUD





 **POS-150**  
PHILLIPS OVAL HEAD SCREW ASSORTMENT

<b>655</b>  #10 X 3/4"-#8 HEAD	<b>658</b>  #10 X 1"-#6 HEAD
<b>660</b>  #10 X 1-1/2"-#6 HEAD	<b>659</b>  #10 X 1"-#8 HEAD





 **POS-160**  
PHILLIPS OVAL HEAD SCREW ASSORTMENT

<b>636</b>  #8 X 1" (# 6 HEAD)	<b>639</b>  #8 X 1-1/4" (# 6 HEAD)
<b>2501</b>  #8 X 1-1/2" (# 6 HEAD)	<b>641</b>  #8 X 1-3/4" (# 6 HEAD)







 **POS-260**  
PHILLIPS OVAL HEAD SCREW ASSORTMENT

<b>633</b>  #8 X 5/8"-#6 HEAD	<b>2498</b>  #8 X 3/4"-#6 HEAD
<b>635</b>  #8 X 3/4"	<b>637</b>  #8 X 1"

 **PPS-255**  
PHILLIPS PAN HEAD SCREW ASST.

<b>680</b>  #6 X 1/2"- ZINC	<b>682</b>  #8 X 1/2"- ZINC
<b>684</b>  #10 X 1/2"- ZINC	<b>686</b>  #10 X 3/4"-ZINC





 **QEC-120**  
QUICK ELECTRICAL CONNECTOR ASSORTMENT

<b>424</b>  RING TONGUE #16-14 WIRE; #8-10 STUD	<b>433</b>  SPADE TONGUE #16-14 WIRE; #8-10	<b>441</b>  BUTT CONNECTOR NYLON
<b>446</b>  MALE QUICK DISCONNECT #16-14 WIRE	<b>445</b>  FEMALE QUICK DISCONNECT #16-14 WIRE	<b>449</b>  SNAP PLUG #16-14 WIRE







## PLASTIC PAK ASSORTMENTS







	<b>SEMS-70</b> CHROME FINISHING SEMS ASSORTMENT
--	---

<b>1653</b>  #8 X 1" (#6 HEAD)	<b>1659</b>  #10 X 1" (#6 HEAD)
<b>1651</b>  #8 X 5/8" (#6 HEAD)	<b>1652</b>  #8 X 3/4" (#6 HEAD)

	<b>STGA-195</b> SELF THREADING NUT ASSORTMENT
--	---

<b>920</b>  1/8" STUD	<b>921</b>  3/16" STUD
<b>922</b>  1/4" STUD	<b>923</b>  5/32" STUD







	<b>TXS-110</b> TORX DRIVE SHEET METAL SCREW ASSORTMENT
--	--

<b>2184</b>  4.2MM X 20MM OVAL HD CHROME	<b>2186</b>  4.2 MM X 20MM PAN HD. CHROME	<b>2188</b>  4.2MM X 30MM OVAL HD.CHROME
<b>2185</b>  4.2 MM X 20MM OVAL HD.-BLACK	<b>2187</b>  4.2MM X 20MM PAN HEAD-	<b>2189</b>  4.2MM X 30 MM OVAL HD.







	<b>TCA-290</b> TUBULAR CLIP ASSORTMENT
--	---

<b>874</b>  3/32" STUD	<b>875</b>  1/8"STUD	<b>878</b>  3/16" STUD
<b>878</b>  3/16"STUD	<b>879</b>  3/16" STUD	<b>879</b>  3/16" STUD



	<b>SRA-100</b> UNTHREADED STUD RETAINER ASSORTMENT
---	--

<b>2464</b>  3/32" STUD	<b>2465</b>  1/8" STUD	<b>2466</b>  5/32" STUD
<b>2467</b>  3/16" STUD	<b>2468</b>  1/4" STUD	<b>2469</b>  3/8" STUD

	<b>TKS-105</b> SELF-DRILLING SCREW ASSORTMENT
---	---

<b>2222</b>  #8X1/2"-ZINC	<b>2340</b>  #8X1/2"-BLACK	<b>2463</b>  4.2 MM X20 MM FLUSH WSHR
<b>2482</b>  #8X7/8"- ZINC	<b>2484</b>  4.2 MM X 20 MM FLUSH WSHR	<b>2685</b>  #8X1/2"-BLACK

	<b>VTA-26</b> VACUUM TEE ASSORTMENT
---	--

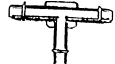
<b>2427</b>  3/16" X 3/16" CONNECTOR	<b>2430</b>  1/8"X 1/8"X1/8" 3 WAY TEE
<b>2426</b>  3/16"X 3/16"X3/16" 3 WAY TEE	<b>2431</b>  1/4"X 1/4"X1/4" 3 WAY TEE

PLEASE VISIT OUR WEBSITE AT:

**WWW.WESALES.COM**



## PLASTIC PAK ASSORTMENTS

<b>FL-1400</b> <b>FLAT WASHER, LOCK WASHER ASSORTMENT</b> <b>(DRAWER SIZE - 13-1/8" X 9" X 2-5/16")</b>					
<b>4200</b>  <b>3/16"</b> <b>FLAT WASHER</b>	<b>4201</b>  <b>1/4"</b> <b>FLAT WASHER</b>	<b>4202</b>  <b>5/16"</b> <b>FLAT WASHER</b>	<b>4203</b>  <b>3/8"</b> <b>FLAT WASHER</b>	<b>4204</b>  <b>7/16"</b> <b>FLAT WASHER</b>	<b>4205</b>  <b>1/2"</b> <b>FLAT WASHER</b>
<b>4210</b>  <b>3/16"</b> <b>LOCK WASHER</b>	<b>4211</b>  <b>1/4"</b> <b>LOCK WASHER</b>	<b>4212</b>  <b>5/16"</b> <b>LOCK WASHER</b>	<b>4213</b>  <b>3/8"</b> <b>LOCK WASHER</b>	<b>4214</b>  <b>7/16"</b> <b>LOCK WASHER</b>	<b>4215</b>  <b>1/2"</b> <b>LOCK WASHER</b>











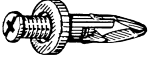

<b>MW-1000</b> <b>METRIC FLAT WASHER, LOCK WASHER ASSORTMENT</b> <b>(PLASTIC BOX SIZE-11" X 6-3/4" X 1-3/4")</b>					
<b>5970</b>  <b>4 MM</b> <b>FLAT WASHER</b>	<b>5971</b>  <b>5 MM</b> <b>FLAT WASHER</b>	<b>5949</b>  <b>6 MM</b> <b>FLAT WASHER</b>	<b>5950</b>  <b>8 MM</b> <b>FLAT WASHER</b>	<b>5951</b>  <b>10 MM</b> <b>FLAT WASHER</b>	<b>5951</b>  <b>10 MM</b> <b>FLAT WASHER</b>
<b>5972</b>  <b>4 MM</b> <b>LOCK WASHER</b>	<b>5973</b>  <b>5 MM</b> <b>LOCK WASHER</b>	<b>5956</b>  <b>6 MM</b> <b>LOCK WASHER</b>	<b>5957</b>  <b>8 MM</b> <b>LOCK WASHER</b>	<b>5958</b>  <b>10 MM</b> <b>LOCK WASHER</b>	<b>5958</b>  <b>10 MM</b> <b>LOCK WASHER</b>

## PLASTIC PAK ASSORTMENTS

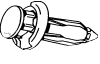

### ACC-131 HONDA ACCORD RETAINER ASSORTMENT (PLASTIC BOX SIZE-11" X 6-3/4" X 1-3/4")



























<p><b>2548</b></p>  <p>(91502-SM4-000) SCREW RIVET- BUMPER FASCIA HONDA -'90 &amp; UP HOLE SIZE-10 MM HD. DIAM.-20 MM; STEM- 27 MM</p>	<p><b>2549</b></p>  <p>(91504-SM4-000) SCREW RIVET- BUMPER FASCIA OCTAGONAL HEAD HONDA -'90 &amp; UP HOLE SIZE-10 MM</p>	<p><b>2609</b></p>  <p>(91503-SP0-0030) SCREW RIVET BUMPER STRIP RETAINER ACURA-'91 &amp; UP HOLE SIZE-10MM; HD. DIAM.-20 MM STEM LENGTH- 15 MM</p>	<p><b>2613</b></p>  <p>(90505-SM4-003) SCREW RIVET, SILL PLATE MOUNTING; HONDA ACCORD HOLE SIZE-8 MM HD. DIAM.-18 MM</p>	<p><b>2758</b></p>  <p>(91512-SM4-003) SCREW RIVET FENDER SPLASH SHIELD HONDA ACCORD '90 &amp; UP HOLE SIZE-8 MM; HD. DIAM.-20 MM STEM LENGTH- 9 MM</p>	<p><b>2844</b></p>  <p>(N807438S, W704643) (REPLACES-91568-SR2-003, 91530 -SP1-003 ) WEATHERSTRIP RETAINER FORD &amp; HONDA HOLE SIZE-5 MM HEAD SIZE-5 X 15 MM STEM-10 MM</p>
<p><b>2883</b></p>  <p>(91503-SZ3-003) PLASTIC PUSH RIVET FRONT GRILLE AND BUMPER HONDA- '96 &amp; UP HOLE SIZE-10 MM; FLANGE O.D.-20 MM STEM-13 MM</p>	<p><b>2884</b></p>  <p>(91502-SPO-003) PLASTIC SCREW RIVET FRONT AND REAR BUMPER HONDA-'90 &amp; UP HOLE SIZE-10 MM; HD. DIAM.-20 MM</p>	<p><b>2889</b></p>  <p>(91512-SXO-003) PLASTIC PUSH RIVET FRONT FENDER HONDA- HOLE SIZE-8MM; HD. DIAM.-20MM OVERALL LENGTH- 13.4</p>	<p><b>2898</b></p>  <p>(91503-SZ5-003) PLASTIC PUSH RIVET FRONT GRILLE AND BUMPER HONDA- '98 &amp; UP HOLE SIZE-10 MM FLANGE OD-20 MM; STEM-17 MM</p>	<p><b>2966</b></p>  <p>(91518-SM4-003) RETAINER-HOOD &amp; TRUNK MOUNTING HONDA- ACURA &amp; CIVIC-'94 &amp; UP HOLE SIZE-6 MM HEAD DIAM.-12 MM STEM-9 MM</p>	<p><b>2973</b></p>  <p>(90700-SJ4-000) HOOD INSULATION CLIP- HONDA- ACCORD-'91 &amp; UP HEAD DIAM.-30 MM OVERALL LENGTH -12 MM</p>



### TEK-530 "SELF DRILLING" TYPE SCREW ASSORTMENT (DRAWER SIZE - 13-1/8" X 9" X 2-5/16")



<p><b>2409</b></p>  <p>UNSLOTTED HEX WASHER HEAD #8 X 1/2"</p>	<p><b>2150</b></p>  <p>UNSLOTTED HEX WASHER HEAD #8 X 3/4"</p>	<p><b>2659</b></p>  <p>UNSLOTTED HEX WASHER HEAD #8 X 1"</p>	<p><b>2620</b></p>  <p>UNSLOTTED HEX WASHER HEAD #10 X 1/2"</p>	<p><b>2660</b></p>  <p>UNSLOTTED HEX WASHER HEAD #10 X 3/4"</p>	<p><b>2275</b></p>  <p>UNSLOTTED HEX WASHER HEAD #10 X 1"</p>
<p><b>2764</b></p>  <p>UNSLOTTED HEX WASHER HEAD #12 X 3/4"</p>	<p><b>2765</b></p>  <p>UNSLOTTED HEX WASHER HEAD #14X3/4"</p>	<p><b>2486</b></p>  <p>UNSLOTTED HEX WASHER HEAD #14 X 1"</p>	<p><b>3068</b></p>  <p>UNSLOTTED HEX WASHER HEAD#14 X 1-1/4"</p>	<p><b>3069</b></p>  <p>UNSLOTTED HEX WASHER HEAD #14 X 1-1/2"</p>	<p><b>2685</b></p>  <p>PHILLIPS FLAT TOP WASHER HEAD #8 X 1/2"-BLACK</p>
<p><b>2222</b></p>  <p>PHILLIPS OVAL WASHER HEAD #8 X 1/2"-BRIGHT</p>	<p><b>2340</b></p>  <p>PHILLIPS FLAT WASHER HEAD #8 X 1/2"-BLACK</p>	<p><b>2796</b></p>  <p>PHILLIPS FLAT TOP WASHER HEAD-BLACK 4.2 X 16 MM</p>	<p><b>2797</b></p>  <p>PHILLIPS FLAT TOP WASHER HEAD-BLACK 4.2 X 19 MM</p>	<p><b>2798</b></p>  <p>PHILLIPS FLAT TOP WASHER HEAD-BLACK 4.2 X 25 MM</p>	<p><b>2482</b></p>  <p>PHILLIPS ROUND WASHER HEAD #8 X 7/8"-ZINC</p>
<p><b>2657</b></p>  <p>PHILLIPS PAN HEAD #8 X 1/2"-ZINC</p>	<p><b>2658</b></p>  <p>PHILLIPS PAN HEAD #8 X 1"-ZINC</p>	<p><b>2996</b></p>  <p>PHILLIPS OV HD FINISHING SEMS COUNTERSUNK WSHR #8 X 3/4" -CHROME</p>	<p><b>2997</b></p>  <p>PHILLIPS OV HD FINISHING SEMS COUNTERSUNK WSHR #8 X 3/4" -BLACK</p>	<p><b>3015</b></p>  <p>INDENTED HEX WSHR HD- 12 MM LS WSHR 4.2 X 20 MM-BLACK</p>	<p><b>3016</b></p>  <p>INDENTED HEX WSHR HD- 16 MM LS WSHR 4.2 X 20 MM-BLACK</p>



### CTA-400 BLACK CABLE TIE ASSORTMENT

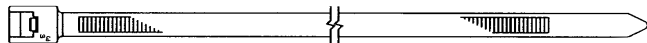

IN REUSABLE HANG-UP PLASTIC BOX-CONTAINS 400 CABLE TIES:  
 (200-4" 18# TENSILE STRENGTH-#2865)  
 (100-7" 50# TENSILE STRENGTH-#2385)  
 (100-11" 50# TENSILE STRENGTH-#2386)  
 UNIT PKG.-1



## THREADED INSERT KITS

### NT-11 USS THREADED INSERT KIT

KIT CONTAINS:

- 2154-10-24 INSERT (9/32" REQUIRED HOLE SIZE)
- 2155-1/4-20 INSERT (3/8" REQUIRED HOLE SIZE)
- 2156-5/16-18 INSERT (1/2" REQUIRED HOLE SIZE)

- NT-11-1024-TOOL
- NT-11-1/4-20-TOOL
- NT-11-5/16-18-TOOL
- UNIT PKG.-1



### NT-15M METRIC THREADED INSERT KIT

KIT CONTAINS:

- 5974-4 MM INSERT
- 5942-6 MM INSERT
- 5943-8 MM INSERT
- 5944-10 MM INSERT
- NT-15M-4-TOOL
- NT-15M-6-TOOL
- NT-15M-8-TOOL
- NT-15M-10-TOOL

UNIT PKG.-1



### THREADED INSERT TOOLS

- NT-11-1024 (USE FOR #2154)
- NT-11-1/4-20 (USE FOR #2155 & 2903)
- NT-11-5/16-18 (USE FOR #2156)
- NT-15M-4 (USE FOR #5974 & 3300)
- NT-15M-5 (USE FOR #3085 & 3149)
- NT-15M-6 (USE FOR #5942 & 2904)
- NT-15M-8 (USE FOR #5943)
- NT-15M-10 (USE FOR #5944)

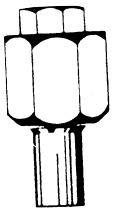

EACH UNIT PKG.-1

### THREADED INSERTS-STEEL, PLATED



<u>PART #</u>	<u>THREAD SIZE</u>	<u>HOLE SIZE</u>	<u>PANEL RANGE</u>	<u>UPKG.</u>
<b>2154</b>	10-24	9/32"	.03-.165"	25
<b>2155</b>	1/4-20	3/8"	.03-.165"	25
<b>2156</b>	5/16-18	1/2"	.03-.165"	10
<b>5974</b>	4 MM	6.75 MM	0.5-2.0 MM	25
<b>3149</b>	5 MM	7.6 MM	0.5-3.3 MM	25
<b>5942</b>	6 MM	10.0 MM	0.7-4.2 MM	15
<b>5943</b>	8 MM	13.5 MM	0.7-3.8 MM	10
<b>5944</b>	10 MM	13.5 MM	0.7-3.8 MM	10

### THREADED INSERTS- HEXAGONAL HOLE STEEL, PLATED



<u>PART #</u>	<u>THREAD SIZE</u>	<u>PANEL RANGE</u>
<b>2903</b>	1/4-20	.03-.165"
	(3/8" ACROSS THE FLAT)	
<b>3300</b>	4 MM	2-3.3 MM
	(9 MM HEAD DIAMETER 6.35 MM ACROSS THE FLATS)	
<b>3085</b>	5 MM	0.5-3.3 MM
	(7 MM HEX, 10 MM HEAD DIAM.)	
<b>2904</b>	6 MM	0.7-4.2 MM
	(9.5 MM ACROSS THE FLAT)	

EACH UNIT PKG.-15

# EFA LARGE METAL DRAWER ASSORTMENTS:

(DRAWER SIZE: 18" X 12" X 3")



**CONTAINS ONE FULL BOX OF EACH FASTENER ITEM IN THAT PARTICULAR CATEGORY**

<b>PART #</b>	<b>DESCRIPTION</b>
<b>EFA-1</b>	<b>PLASTIC "CHRISTMAS TREE" FASTENERS, WEATHERSTRIP &amp; HOOD CLIPS, GROMMETS (840 PCS.)</b>
<b>EFA-2</b>	<b>PLASTIC PUSH TYPE AND SCREW RIVET RETAINERS-DOMESTIC AND IMPORTS (470 PCS.)</b>
<b>EFA-3</b>	<b>SPECIAL SHEET METAL SCREWS, CLIP NUTS, SPECIALTY RIVETS, BOLTS AND SHIMS (1,730 PCS.)</b>
<b>EFA-4</b>	<b>METRIC BODY BOLTS, FREE SPINNING AND FLANGE NUTS AND "U" TYPE NUTS (715 PCS.)</b>

**EACH UNIT PKG.-1**



## EFA-5 ESSENTIAL AUTO BODY FASTENER ASSORTMENT SET UP



A FULLY LABELED, LARGE DRAWER ASSORTMENT  
OF 94 ESSENTIAL BODY SHOP FASTENERS.

IDEAL FOR THE SHOP THAT WANTS TO ORGANIZE THEIR MOST OFTEN NEEDED  
FASTENERS. COMBINED WITH THE INCLUDED W&E SALES "WE TRAK" SOFTWARE,  
FASTENERS USED ON A SPECIFIC JOB CAN BE INVOICED SEPARATELY. THE COMPLETE  
SETUP INCLUDES: FOUR FULLY LABELED DRAWERS A HEAVY DUTY STEEL RACK, ONE  
BOX OF EACH PART IN THE ASSORTMENT, (A TOTAL OF 3,755 PIECES)  
AND ONE COPY OF THE "WE TRAK" INVOICING SOFTWARE.

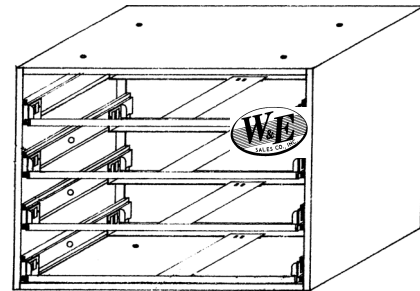

### EFA ASSORTMENT PARTS LISTING

#### EFA-1:

818  
1223  
1225  
2140  
2204  
2274  
2347  
2356  
2364  
2379  
2414  
2418  
2493  
2494  
2523  
2618  
2628  
2643  
2644  
2687  
2844  
2230  
2230  
2230

#### EFA-2:

2216  
2264  
2265  
2266  
2267  
2361  
2366  
2388  
2398  
2415  
2420  
2460  
2491  
2548  
2550  
2551  
2609  
2613  
2758  
2883  
2885  
2886  
2889  
2898

#### EFA-3:

811  
915  
942  
965  
966  
1220  
2121  
2122  
2123  
2162  
2193  
2203  
2222  
2226  
2255  
2322  
2340  
2345  
2353  
2354  
2452  
2480  
2630  
2688

#### EFA-4:

2423  
5901  
5902  
5903  
5904  
5906  
5908  
5910  
5911  
5920  
5921  
5922  
5923  
5924  
5931  
5938  
5940  
5941  
5947  
5948  
5952  
5962  
5963  
5965



## STORAGE CABINETS/ RACKS

**18D**

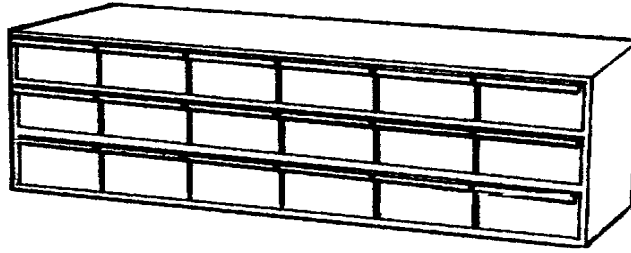

**18 DRAWER STORAGE CABINET MADE OF HEAVY STEEL CONSTRUCTION. VERY USEFUL TO THE SHOP THAT NEEDS THEIR FASTENER AREA ORGANIZED. EACH SLIDE OUT DRAWER CAN BE SECTIONED OFF INTO THREE COMPARTMENTS TO MAXIMIZE THE NUMBER OF ITEMS BEING STORED. A PERFECT WAY TO SET UP A NEW CUSTOMER OR ORGANIZE AN OLD ONE.**

**WIDTH-34" HEIGHT-11" DEPTH-11-5/8"  
UNIT PKG.-1**

**36B**

**36 COMPARTMENT  
STORAGE BIN  
"SLIDE OUT  
DIVIDERS"**

**WIDTH-23-5/8" HEIGHT-23-  
5/8" DEPTH-4-3/4"**

**CAN BE WALL MOUNTED**

**UNIT PKG.-1**

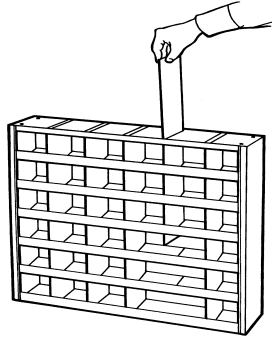

**PB-18**

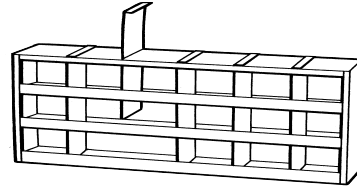

**18 COMPARTMENT STORAGE BIN  
"SLIDE OUT  
DIVIDERS"**

**WIDTH-23-3/4" HEIGHT-12-1/4" DEPTH-4-3/4"**

**CAN BE WALL MOUNTED**

**UNIT PKG.-1**

**CR-4  
AND  
CR-6**

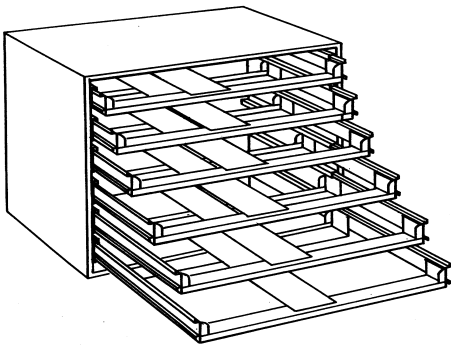

**CABINET RACKS CONTAINING 4 OR 6  
"SLIDE OUT" DRAWER BRACKETS.  
OUTSIDE DIMENSIONS:**

**CR-4: 15-1/4" WIDE, 11-3/4" DEEP, 10-3/4" HIGH**

**CR-6: 15-1/4" WIDE, 11-3/4" DEEP, 15-1/2" HIGH**

**EACH RACK HOLDS W&E PARTS B-12 OR B-24  
DRAWERS**

**(DRAWERS NOT INCLUDED)**

**EACH UNIT PKG.-1**

**4LR**

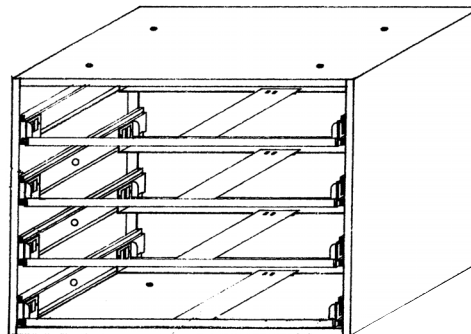

**LARGE CABINET RACK  
CONTAINING 4**

**"SLIDE OUT" DRAWER BRACKETS.  
OUTSIDE DIMENSIONS:**

**20" WIDE, 15-3/4" DEEP, 14-1/2" HIGH**

**HOLDS 4-W&E# DL-24 DRAWERS**

**(DRAWERS NOT INCLUDED)**

**UNIT PKG.-1**

## STORAGE CABINETS/ RACKS/ DRAWERS

**DL-24**

LARGE 24 COMPARTMENT  
METAL STORAGE DRAWER.  
USE WITH 4LR STORAGE RACK.  
WIDTH-18" DEPTH-12" HEIGHT-3"

UNIT PKG.-1

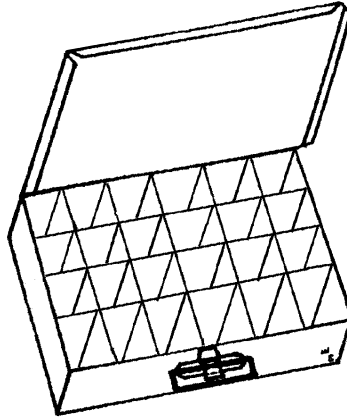

**PLR-5**

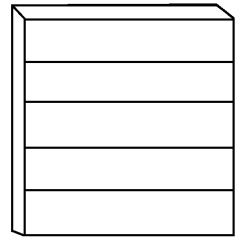

METAL STORAGE RACK FOR  
PARTS PL-12 & PL-24  
SIZE:13-1/2"X13-1/4"X9-1/8"  
HOLDS FIVE STORAGE BOXES  
UNIT PKG.-1

**B-12:**

12 COMPARTMENT METAL STORAGE DRAWER

**B-16:**

16 COMPARTMENT METAL STORAGE DRAWER

**B-24:**

24 COMPARTMENT METAL STORAGE DRAWER

USE WITH W & E PART # CR-4 OR CR-6  
PLASTIC INSERT CONTAINS "SCOOP OUT"  
COMPARTMENTS-IDEAL FOR STORAGE OF SMALL PARTS.  
DIMENSIONS: 13-3/4" WIDE, 9-1/4" DEEP, 2" HIGH

EACH UNIT PKG.-1

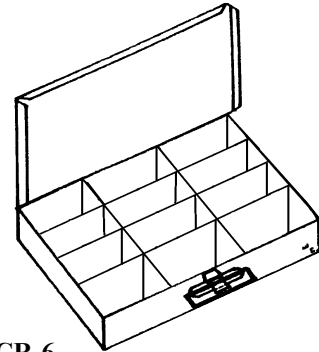

**30D**



30 COMPARTMENT METAL STORAGE  
CABINET  
WITH 30 PLASTIC DRAWERS WITH  
DIVIDERS. SPACE SAVING STORAGE  
FOR A VARIETY OF NEEDS.  
DIMENSIONS:  
12" WIDE, 5-3/4" DEEP, 21-7/8" HIGH

UNIT PKG.-1

### POLYPROPYLENE STORAGE BOXES

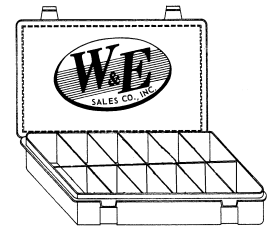
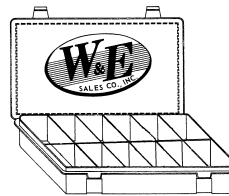

PART #	SIZE	COMPARTMENTS
<b>M-602</b>	11"X6-3/4"X1-3/4"	12
<b>PL-12</b>	13-1/8"X9"X2-5/16"	12
<b>PL-24</b>	13-1/8"X9"X2-5/16"	24

(PL-12 & PL-24 CAN BE USED WITH THE PLR-5 RACK AT TOP OF PAGE)

EACH UNIT PKG.-1



# **WE TRAK® AND WETRAK3®**

## **FASTENER INVOICING SOFTWARE**



“WE TRAK” is a complete software program designed for body and glass shops to create supplemental invoices for fasteners and shop supplies. The ability to produce receipts that are acceptable to the insurance companies should make the small amount of data entry well worth the time required.

“WE TRAK” features the following:

- Complete listing of W&E part numbers; with descriptions and per piece cost pricing.
- A markup recalculation feature allowing the shop to set their own profit margin.
- A customer database section to store and maintain customer records.
- Other supplies used in the shop can be added to the system as needed.

Each “WE TRAK” software program is shipped with the W&E distributor’s name, address and phone number hard coded into the program. Once installed on the shop’s computer, call to register the program with W&E. All we need is the shop name and a password will be issued.

Updates for new items and any price changes will be available by email-  
Part number **WTUE** or by CD- Part number- **WTUCD**.

The “WETRAK3” program offers the following new features:

- 1.-The ability to receive scanned information into the program. Eliminates the need to manually key information into the system. Use your own barcode scanner.
- 2.-Inventory control- helps keep track of your hardware usage while allowing you to maintain an adequate supply of body fasteners. Jobbers may scan the label on the W&E parts box and the inventory will automatically update.
- 3.-The ability to produce your own bin labels containing the part number, description and a bar code for any part entered into the system.
- 4.-Use your existing computer or net book to run the software.

There are two ordering options:

- 1.- **WETRAK**- Basic part invoicing program.
- 2.- **WETRAK3®**- software program for shops who prefer to use their own scanner & track inventory.

(Simply install the software on your existing computer, call W&E Sales to register your program.)

**Unit Pkg.-1**



## OEM/W&E CROSS REFERENCE GUIDE

OEM #	W&E #	PG. #	OEM #	W&E #	PG. #	OEM #	W&E #	PG. #
000-988-1581	2197	14	10126901	2705	42	11500661	5903	86
000-988-6081	2315	15	10131511	3190	69	11500662	5904	86
000-988-7881	2317	16	10134407	2398	46	11500961	5905	87
003-988-1978	2195	18	10137292	2810	108	11500970	5906	87
003-988-2078	2196	18	10140480	2682	58	11500971	5984	87
008934202672	2398	46	10142872	2908	64	11500996	2634	74
01281-00023	2277	100	10143422	2455	35	11501003	2800	74
01281-00111	3092	103	10146315	2863	38	11501099	5965	91
01281-00691	3338	104	10153057	2490	42	11501188	5910	88
01281-00831	3211	104	10157900	2739	49	11501189	5955	88
01281-01081	3168	103	1016937	5920	86	11501193	5911	88
01281-01321	3169	103	10169777	3011	29	11501794	2259	83
01553-00051	2278	35	10182300	3097	40	11501836	USE 2562	94
01553-00172	2379	28	10184895	2485	72	11501849	5926	92
01553-00291	2964	31	10185866	2952	38	11501850	5909	91
01553-00755	2614	48	10185925	2347	37	11501867	2763	80
01553-0075U	3170	40	10195515	2718	58	11501883	2860	83
01553-01393	2624	57	10201332	3193	69	11501884	2226	76
01553-0167U	3215	53	10246149	3024	59	11501889	5931	91
01553-02821	3059	45	10257286	2978	44	11501896	2227	77
01553-03101	2477	57	10262143	2984	102	11501903	2225	76
01553-03831	2369	18	10274778	3045	65	11501929	3115	79
01553-05323	3346	56	10283414	2845	28	11501932	5914	94
01553-06721	2599	48	10285935	2795	43	11502470	2463	81
01553-09241	3040	51	10287926	3039	17	11502504	5917	92
01553-09321	2959	50	10287971	2794	43	11502507	5946	94
01553-09331	2990	29	10293193	3205	31	11502540	5913	94
01553-09611	3093	52	10293674	2848	29	11502702	5938	91
01553-56500	2706	35	10297370	3279	26	11502785	5901	86
01651-00481	2374	100	10301966	3038	51	11502834	2487	82
04388293	2399	46	10323057	3276	23	11502836	2488	82
0501094C1	2707	42	10352799	3116	23	11502853	5917	92
05257478	2625	62	10352803	3129	23	11502970	5927	88
0G032-50037A	3272	59	10363811	USE #3218	36	11503396	2322	73
10005510	2220	85	10405030	2845	28	11503397	2489	73
10009923	USE 2562	94	10411395	3049	22	11503403	2193	73
10014363	2522	108	10421018	3010	36	11503421	2665	76
10016640	2920	74	10423331	3022	102	11503436	2287	73
10032838	2581	101	10423553	3042	22	11503483	2322	73
10053182	2977	59	10425306	3038	51	11503552	2488	82
10056725	2400	105	10431524	3116	23	11503555	2762	78
10060375	5986	89	10431761	3049	22	11503569	2325	77
10063599	2861	38	10437565	3129	23	11503632	5906	87
10077283	2974	50	10998-3880	2627	57	11503691	5928	94
10077401	2643	38	11296-AG000	3171	52	11503695	5908	91
10093200	2504	35	11500401	5908	91	11503715	5924	86
10109689	2439	72	11500656	5989	86	11503752	5922	91
10121502	2643	38	11500658	5901	86	11503754	5948	91
10125439	3192	69	11500660	5902	86	11503756	5948	91



## OEM/W&E CROSS REFERENCE GUIDE

OEM #	W&E #	PG. #	OEM #	W&E #	PG. #	OEM #	W&E #	PG. #
11503800	5967	87	11515903	5940	89	11610383	3220	69
11503823	5947	88	11515923	5991	90	11610605	3344	46
11503834	5923	88	11516807	3332	68	11610606	3345	46
11503892	2193	73	11516908	3120	89	1189106	988	118
11503941	5947	88	11517372	3321	90	11900338	3121	90
11503957	5920	86	11517803	3023	51	1196781	826	99,107
11503958	5981	87	11518017	3078	51	12001470	3032	129
11503982	5921	88	11518201	3009	39	12013813	3199	130
11504010	2258	73	11518357	3035	22	12040983	2855	116
11504069	2184	80	11518755	3317	73	12040984	2854	116
11504493	5921	88	11518988	3280	23	12048369	2846	129
11504522	3314	80	11519031	3296	45	12078178	3032	129
11504646	2744	80	11519032	3299	45	12083005	3030	129
11504647	2186	80	11519444	3023	51	12083680	3031	129
11504655	2187	80	11519949	2889	49	12084605	2117	41
11504656	2189	80	11561368	3210	53	12085330	3033	129
11504659	2185	80	11561448	see 2675	16	12116169	3032	129
11504766	2345	77	11561491	repl by 3282	24	12338015	2944	111
11504774	2240	80	11561499	3218	36	12338074	2741	109
11505022	2423	73	11561654	3315	45	12353912	2979	65
11505023	2634	74	11561655	3207	103	1247708	2163	14
11505044	5962	88	11561857	3204	20	1264963	2581	101
11505104	2859	76	11561874	3018	51	1304967	2374	100
11505204	2746	74,80	11562024	3311	40	13252118	3344	46
11505214	5948	91	11562250	3312	24	13252119	3345	46
11505329	5922	91	11562563	3322	24	1355003	2338	98
11505596	5989	86	11569973	repl by 3278	23	135603	825	99
11506099	5924	86	11571159	3342	34	1370853	2338	98
11507083	2256	73	11571175	3313	24	1377030	2173	99
11508241	5924	86	11588286	3118	76	1379013	836	95
11508879	2745	80	11588643	3343	61	1383497	836	95
11508925	5902	86	11588650	3331	16	1385235	836	95
11509033	5976	88	11589181	3284	40	1395-68-676	2619	57
11509185	2783	82	11589244	3278	23	14003784	5945	92
11509237	2575	77	11589289	3245	54	14005097	2810	108
11509440	3053	88	11589290	3214	53	14005953	2183	108
11509737	2488	82	11589291	3273	54	14007940	2433	108
11509815	3316	74	11589292	use 3215	53	14013241	2237	56
11513895	2684	74	11589293	3215	53	14013246	2208	99
11514314	2193	73	11589294	3224	53	14015161	2238	18
11514331	2905	78	11589295	3326	55	14017705	2430	117
11514377	2489	73	11589296	3327	55	14019205	2216	46
11514415	2981	75	11609303	repl by 3280	23	14019206	2216	46
11514845	2489	73	11609417	3367	55	14022878	2336	15
11514970	2859	76	11609690	2801	33	14032291	2406	100
11515425	5980	87	11609697	3343	61	14045480	2453	47
11515619	5984	87	11609862	3207	103	14063981	2266	72
11515655	3089	89	11609923	3286	24	14066728	2944	111
11515791	5988	87	11610049	3330	27	14070914	2267	72



## OEM/W&E CROSS REFERENCE GUIDE

OEM #	W&E #	PG. #	OEM #	W&E #	PG. #	OEM #	W&E #	PG. #
14071289	2399	46	15715058	2774	66	171-853-615A	2479	101
14074081	2107	36	15732202	2642	72	171-853-695A	2300	18
14093088	2388	46	15733970	2946	27	171-867-299B	2199	41
14093311	1225	36	15733971	2945	27	175-553-577A	2267	72
14103461	2438	47	15764320	2919	27	175720B010	2399	46
1484570	175	13	15872008	3282	24	175-853-577	2264	72
1493541	1034	96	15953247	2621	42	175-853-695	2237	56
1494253	915	85	15955172	2270	72	175-853-695A	2238	18
1494258	916	85	15958694	2140	36	175-867-299	2246	41
15002520	3081	17	15959832	2701	48	179-813-883	2338	98
1500971	5984	87	15960325	2699	48	20028569	2221	15
15022087	2888	68,95	15963179	2721	42	20032850	2299	37
15025531	2919	27	15964971	2741	109	20033049	3088	87
15056810	3008	39	15964972	2740	109	20036949	2504	35
15076791	3114	45	15967438	3051	75	20043351	2358	110
15127746	3310	24	15967691	2714	110	20046147	2357	110
15149708	2887	49	15969147	2550	47	20064875	2983	33
15153415	2953	50	15986673	2490	42	20085729	2579	65
152867	2143	95	15993201	2739	49	20130258	2906	108
15296830	3260	54	15994165	3133	52	20136601	2233	15
154804	2804	78	15994486	3160	109	20162174	2975	65
15505451	2524	108	1600375	1012	96	20169887	2176	64
15506827	2266	72	1605396	2140	36	20175051	2232	15
15506921	2266	72	1606642	1012	96	20184399	2622	66
15552345	2107	36	1616923	2207	28	20199675	2229	15
15554088	2110	14	1619321	2204	36	20274997	2337	16
15562609	2740	109	1624705	146	13	20298365	2899	43
15562610	2753	112	1629341	1212	60	20319841	3056	39
15591860	2714	110	1631564	2356	37	20325696	3289	69
15594541	2676	61	1644290	3170	40	20345137	2282	109
15599064	2367	37	16500308	2413	46	20351035	5923	88
15600382	2274	41	16502342	3147	106	20369894	3002	65
15607165	2511	42	16504937	2580	98	20369895	3003	65
15612948	2511	42	16505374	2580	98	20374473	2462	42
15614746	2266	72	16508139	2580	98	20375022	2293	16
15638413	2721	42	1654047	355	63	20413107	2414	28
1564180	945	90	1654048	354	63	20421672	2270	72
15653790	2896	111	16600199	3258	87	20421800	2274	41
15676621	2299	37	16601263	2507	62	20429500	2284	109
15681408	3215	53	166066936	2538	62	20432975	2264	72
15682898	3081	17	16606936	2538	62	20433026	2267	72
15683591	5940	89	16630688	2625	62	20451401	2286	41
15685040	2714	110	16632192	2740	109	20452072	2485	72
15685073	2941	62	16632193	2741	109	20465395	2640	72
15686142	2675	16	16656935	2224	41	20478732	2955	65
15691493	2741	109	16674629	3064	39	20487630	2979	65
15691595	2714	110	16675980	2951	62	20510029	2398	46
15709267	3184	94	1699250	2107	36	20514862	2365	37
			1717924	2441	61	20538173	2759	28



## OEM/W&E CROSS REFERENCE GUIDE

OEM #	W&E #	PG. #	OEM #	W&E #	PG. #	OEM #	W&E #	PG. #
20570245	2420	47	22641917	3027	67	34201631	2266	72
20582532	2509	62	22642007	2786	17	34201681	2246	41
20582533	2510	62	22643056	2774	66	34202599	2455	35
20590899	2398	46	22718305	3208	34	34202672	2398	46
20603072	378	63	22722859	3218	36	34202787	2356	37
20612732	2640	72	22722860	3203	36	34202855	2264	72
20625733	2980	94	23270-30895	2619	57	342271	2285	108
20664091	2415	56	2486468	2457	109	343541	839	97
20664092	2460	56	25016383	2414	28	343542	839	97
20699808	2652	28	2524526	830	95	343543	1040	97
20712172	2979	65	25501771	2175	18	345220	2505	62
20712176	2979	65	25512081	2546	116	345221	2506	62
20729795	5977	90	25524005	2641	72	347347	2244	100
20732399	1225	36	25535963	2809	27	354076	839	97
20734005	2552	42	25601491	2976	39	354076	1040	97
20747509	2955	65	25606274	2769	16	355891	875	105
2088248	2367	37	25609048	3217	69	357020	2426	117
21030249	2550	47	25618730	2480	68	363137	2291	41
21035345	2985	50	25630258	2775	67	365266	2116	96
21039129	2656	32	25631448	3091	20	365270	2116	96
21042045	2561	35	25640776	2782	74	365270	2124	97
21042053	2561	35	25642453	3212	53	3671410	2426	117
21042058	2561	35	25655545	3238	76	367292	2183	108
21042104	2561	35	25665391	3009	39	367292	2432	108
21075686	2551	47	25693852	3108	23	3673945	2426	117
21077123	2902	49	25695687	3132	52	3691590	1225	36
21077131	2986	50	25722671	3036	22	3691590	2140	36
21077575	2628	28	25724529	3043	22	3691599	1010	96
21094146	2629	38	25744385	3360	21	372820-S36	2330	67
21095797	2757	49	25796285	3358	23	373846-S	2426	117
21097292	2628	28	26022-H1010	2211	98	374684-S32	879	105
21110201	2629	38	26023-H1000	2212	98	3750535	988	118
2193101	2254	15	2785842	1032	96	3751212	2430	117
22189414	3099	40	2811852	1290	62	3783004	825	99
22508050	2426	117	2945108	2507	62	3783005	825	99
22508051	2427	117	2945109	2508	62	379046-S	818	99,107
22512276	2512	38	29818-474D3	2494	101	379830-S	819	99
22514578	2247	100	2998430	1223	32	380382	2338	98
22520368	2810	108	30006620	2851	43	380614-S	2428	117
22520702	2676	61	3065575	2224	41	380707-S	2295	107
22535007	2437	47	3066259	2280	64	3816659	2290	116
22543363	2975	65	3078511	2230	32	383003	2427	117
22569178	2776	67	3081052	3012	62	383033-S101	1210	60
22575287	2459	37	309414	2682	58	383142-S	2104	47
22578214	2775	67	31100005	2200	60	383927S	1222	32
22579423	2776	67	326177	2254	15	384051-S	1222	32
22585836	3027	67	332364	1225	36	384939-S47	2222	83
22587036	2729	48	34201347	2443	61	385189	2121	66
22603384	3044	22	34201621	2216	46	385323-S100	2122	66



## OEM/W&E CROSS REFERENCE GUIDE

OEM #	W&E #	PG. #	OEM #	W&E #	PG. #	OEM #	W&E #	PG. #
385330-S	1224	32	407217	945	90	4857345AA	3187	52
385661S	2367	37	4103165	2443	61	4876498	1206	28
386122S	2214	100	4104998	2427	117	4878883AA	2927	33
386132-S	2546	116	4114785	1212	60	4883164	351	14
386132	2546	116	411700	2108	36	5113-1816-019	2310	15
3861577	2299	37	411846	841	95	5113-1849-724	2311	15
3863669	829	95	411847	842	95	5113-1869-559	2308	15
3868985	2119	96	411-853-575	2303	15	5113-6440-146	2303	15
387258-S	2299	37	4200408	5965	91	5116530AA	3260	54
387477-S	2363	35	4216535	2237	56	5118-1852-299	2305	100
387496-S	2117	41	4234830	2273	62	5147-1-840-961	2306	15
388047-S100	2123	66	4280727	2635	110	5183468AA	2809	27
388047-S102	2452	66	4280729	2600	112	52009077	2752	33
3880632	832	98	4336115	2637	109	5201269	2119	96
388246A	2414	28	4341060	2957	33	5201359	2119	96
388378	2441	61	4370132	2267	72	52161-02020	2885	49
388442-S100	2353	67	4370138	2653	72	52161-16010	2885	49
388577S	2140	36	4381385	2900	38	52161-20010	3235	53
388664-S100	2354	67	4388249	2456	97	52535-50060	3264	104
388904S	2900	38	4422660	384	63	52575-30180	3294	21
388908-S	2425	32	4474354	384	63	53326-52010	3366	16
388930-S	2418	37	4492962	341	14	53455-14020	2767	61
389138	2427	117	4506041	385	63	53867-47020	3337	26
389268-S100	2622	66	45263-S2	910	85	53879-14010A	2496	25
389358S	1225	36	45264-S2	915	85	53879-14020	2496	25
3893980	817	99	45269	917	85	53879-16010	3292	25
389443-S	2461	38	4533669	385	63	53879-17020	3292	25
3895904	2430	117	4630088	2642	72	53879-22010	2495	25
390428-S100	2750	68	4630253	2717	48	53879-22030	2496	25
3907444	818	99,107	4630660	2642	72	53879-50020	3291	27
391039-S	2418	37	4658673	2848	29	53879-58010	3233	25
3919773	2244	100	4658676	2625	62	53879-60010	3232	53
3921446	837	97	4676356	2799	DISC.	547609	2929	71
3960314	943	90	4696129	2628	28	5480852	3309	24
3977775	use 2230	32	4696488	2718	58	5505125	2635	110
3986976	2109	22	4696963	3007	39	55055098	2651	18
3986978	844	98	469716	3012	62	55157055-AA	3348	24
3986997	944	90	4717164	2510	62	55157065-AA	3348	24
4001934	2993	34	4717165	2509	62	55157112-AA	3356	60
4003672	2507	62	472450	2442	61	55157112-AB	3356	60
4003673	2508	62	4755299	826	99,107	55074801	2453	47
4003717	2110	14	4759514AB	3025	102	55176248	2388	46
4004569	2140	36	47749-50090	3290	27	554459	1024	95
4004919	2140	36	47749-58010	3234	25	555388	1024	95
4005099	2707	42	480534	1222	32	556196	1011	96
4005470	2105	41	4805405AA	2932	50	556359	1011	96
4005540	353	63	4805770AA	3065	16	557057	1011	96
4006316	2245	105	4806334AA	3263	54	560625	2427	117
4006516	2414	28	4857108	3212	53	56901-S2	2325	77



## OEM/W&E CROSS REFERENCE GUIDE

OEM #	W&E #	PG. #	OEM #	W&E #	PG. #	OEM #	W&E #	PG. #
56902	2227	77	6032723	2345	77	6501352	2560	61
56902-S2	2585	77	6032881	2353	67	6501559	2485	72
56903-S2	3256	77	6032899	2805	78	6501590	2458	47
56904-S2	2345	77	6032975	2360	110	6501792	5961	92
56912-S2	2787	77	6033006	2519	82	6501925	2398	46
56915-S2	2788	77	6033018	3097	40	6502328	2652	28
56916-S2	2586	77	6033801	2514	73	6502573	2719	58
57728AC090	3040	51	6033862	2707	42	6502586	2459	37
58974-00008	2408	17	6034212	3190	69	6502625	2682	58
5970995	2522	108	6034703	2666	74	6502776	2784	17
5973400	2223	46	6034912	3236	80	6502790	2460	56
5973823	2351	46	6035188	2666	74	6502842	2656	32
5FR56DX9	2892	17	6035201	2630	68	6502871	2460	56
5R3Z-54310D12-BAA	3365	40	6035296	2406	100	6502907	2727	43
600020	875	105	6035401	3271	104	6502991	2726	42
6000752	879	105	6036042AA	2879	105	6503106	2912	50
6002092	2402	13	61A-1808-0019	2210	99	6503108	2720	101
6003349	2105	41	6100040	5989	86	6503163	2977	59
6003351	1224	32	6100049	5948	91	6503204	2849	43
6003518	2110	14	6100568	5968	89	6503274	2752	33
6003575	2141	14	62228-61A00	2607	61	6503336	2649	19
6003632	2142	14	622A2-9E000	3018	51	6503339	2650	19
6003654	2190	41	62318-01W00	2368	18	6503401	3091	20
6004212	2640	72	62318-H8500	2369	18	6503454	2216	46
6010082	815	99	62581-14020	2962	43	6503598	2550	47
6010093	146	13	6270163	2279	37	6503709	2760	35
6013122	2899	43	6271989	2357	110	6503819	3091	20
6015149	988	118	6272766	2426	117	6503860	2653	72
6015930	2129	116	6294015	3029	129	6503943	3064	39
6023168	2926	85	6298935	3029	129	6503971	2752	33
6025334	2747	90	6384401 A00	2361	56	6504014	2727	43
6026647	1051	92	63848-01G00	2615	48	6504043	2644	38
6026648	1050	92	63848-35F00	2911	25	6504090	2216	46
6026686	929	93	63848-D0100	2582	25	6504098	2801	33
6027941	2272	108	63848-D4000	2910	25	6504135	3058	34
6028993	2360	110	63876-D5596	2491	57	6504452	2727	43
6029501	2338	98	6500165	5931	91	6504521	2931	50
6030441	2140	36	6500361	2359	110	6505049AA	2982	105
6030519	2101	99	6500369	5932	88	6505292AA	2864	43
6030539	2222	83	6500626	5936	86	6505403AA	2140	36
6031091	2122	66	6500787	2413	46	6505417AA	3098	40
6031115	2121	66	6500859	2264	72	6505539AA	2939	43
6031138	2210	99	6500898	2265	72	6505686AA	3008	39
6031234	2210	99	6500899	2264	72	6505703AA	3026	102
6031321	1225	36	6500911	2266	72	6505918AA	3046	44
6031438	2432	108	6501067	2407	37	6506008AA	2887	49
6031869	2581	101	6501086	2900	38	6506132AA	3244	54
6032138	2321	67	6501178	5961	92	6506293AA	see 2900	38
6032268	2676	61	6501301	2629	38	6506788	3208	34





## OEM/W&E CROSS REFERENCE GUIDE

OEM #	W&E #	PG. #	OEM #	W&E #	PG. #	OEM #	W&E #	PG. #
6507557AA	2414	28	803-353-577	2301	15	90084-46020	3191	21
6507866AA	3185	21	80406-V5002	2638	111	90084-54011	3206	61
6508197AA	3274	60	80410-01G00	2639	109	90084-54012	3209	61
6508712AA	3210	53	807389S	2550	47	90106-SW3-003	2970	102
6508863AA	3245	54	80833-S5000	2618	28	90107-SX0-003	2969	102
6508863AA	3245	54	80915-29A66	2619	57	90108-SW3-003	2968	20
65810-K2000	3094	31	809905N07	2614	48	90157-SP0-901	3082	19
65832-F5000	2583	32	81126-37010	3231	34	90183-03001	2387	61
65846-30F00	2583	32	81127-01010	2611	98	90189-04008	2381	100
65846-40F00	2967	33	81131-12150	2211	98	90189-04013	2473	100
65846-4Z-000	2967	33	81131-89103	2610	98	90189-04033	2502	101
66435-648-000F	2964	31	81132-32121	2611	98	90189-04042	2236	100
66824-01G00	2617	48	82315-38000	3270	44	90189-04059	3333	104
66860-01W01	2592	57	823-867-299	2199	41	90189-04229	3333	104
67771-03020	2416	42	8545-50-786	2768	101	90189-05012	2963	102
67771-03030	2417	42	86590-28000	3277	60	90189-05013	2248	98
67771-06070	2893	43	8717859	373	63	90189-05105	3062	103
67771-12010	2375	41	8727925	2221	15	90189-05142	3237	98
67771-12040	2851	43	8733059	341	14	90189-06001	2277	100
67771-12050	2851	43	8736586	389	64	90189-06006	2965	102
67771-22010	2375	41	8736588	384	63	90189-06010	2503	101
67867-12150	3100	29	8736589	384	63	90189-06013	2494	101
67868-02020	3100	29	8736590	384	63	90189-06028	3063	103
68003844AA	3215	53	87756-35000	3268	104	90189-06042	2374	100
68061648AA	3318	45	87756-38000	3266	23	90189-06065	2494	101
6825-H 5000	2339	100	87756-3D000	3269	18	90189-06131	3340	27
68814-01G00	2612	48	87758-3D000	3265	23	90189-06157	3146	103
69293-30030	3335	63	8799350	2165	15	90189-06177	3334	104
73862-672-0030	2766	28	88970767	3308	56	90189-06193	3281	104
75315-S9A-004	3350	18	8901283	3029	129	90189-06211	3339	105
75315-STK-A01	see 3350	18	8911472	2219	116	90189-06220	3302	104
75316-S9A-004	3351	18	8911497	2289	116	90189-A0002	3302	104
75392-04010	3262	21	8917320	2290	116	90269-04006	3247	70
75392-35200	3262	21	8918527	3029	129	90269-04050	3248	70
75395-33030	3368	16	8919916	3199	130	90269-04051	3249	70
75395-35070	3188	26	893202-599	2455	35	90269-04053	3250	70
75396-35020	3186	26	8934201293	2524	108	90269-05054	3251	70
75397-35010	3188	26	8934201602	2581	101	90269-05065	3252	70
75495-35010	see 3186	26	8934201621	2216	46	90269-06013	3253	70
75522-611-0000	2236	100	8934201631	2266	72	90269-A0006	3249	70
75775-41300	2619	57	8934201681	2246	41	90303-SXO-0030	3174	20
75867AA010	3017	44	8941340270	2963	102	90467-04009	2894	25
75868AA020	3017	44	8941690750	2619	57	90467-04034	3303	30
76334583	386	63	89421-76980	2492	35	90467-05063-C0	3347	60
7642589	2993	34	89421-80270	2408	17	90467-05090-B1	3287	60
76882-0M000	3172	25	8942264920	2375	41	90467-05125	3293	40
76906-T3000	2492	35	8942431900	2619	57	90467-06017-20	2366	56
7731589	345	14	8942981190	2627	57	90467-06161-01	2961	31
796255	2707	42	90080-46010	2523	31	90467-07043	2614	48



## OEM/W&E CROSS REFERENCE GUIDE

OEM #	W&E #	PG. #	OEM #	W&E #	PG. #	OEM #	W&E #	PG. #
90467-07045-22	3061	19	90661-SC7-0030	2374	100	91504-SM4-0000	2549	57
90467-07050	2379	28	90662-671-0030	2339	100	91505-S9A-0032	3202	52
90467-07076-CO	2991	51	90664-671-0030	2618	28	91505-ST7-003ZA	3242	54
90467-07117	3216	53	90670-SG0-003	3072	103	91505-TM8-0030	3371	56
90467-07164	3304	55	90672-SA0-0030	2497	118	91506-S9A-003	3246	54
90467-07166	2958	50	90674-692-0030	2376	64	91507-S84-A11	2971	31
90467-07188	3362	56	90674-SA6-0030	2371	64	91508-SM4-003	3079	51
90467-07201	3295	55	90675-SB0-003	2491	57	91510-SR3-003	2960	17
90467-07211	3254	54	90675-SB3-003	2491	57	91512-SE0-003	2956	62
90467-07214	3285	55	90676-671-0030	2372	20	91512-SM4-003	2758	58
90467-08004	2523	31	90678-SA0-003	2478	47	91512-SX0-003	2889	49
90467-08011	2523	31	90682-SB0-003	3073	103	91513-SMG-E11	3352	27
90467-08136	3336	31	90682-SDA-A01	3354	105	91513-SM4-000	3074	23
90467-08180	3242	54	90682-SEA-003	3355	26	91516-SM4-003	3075	29
90467-08184	3060	19	90684-SA5-0030	2627	57	91518-S10-003	2687	31
90467-08186CO	3297	40	90686-SB0-0030	2502	101	91518-SM4-003	2966	31
90467-08217 use	2889	49	90687-671-0030	2373	35	91520-SM4-C010	2687	31
90467-09006	2972	33	90687-SA5-0030	2379	28	91528-S01-A01	3150	17
90467-09008	2493	32	90688-SB0-003	2475	57	91528-SR4-003	3150	17
90467-09050	2913	33	90700-SB2-003	3083	34	91530-SP1-003	2844	28
90467-09069-06	2492	35	90700-SJ4-000	2973	33	91530-ST5-003	3075	29
90467-09093	2686	58	90814-FC001	3363	34	91533-SG0-0000	3019	51
90467-09145	2655	57	90853-670-003	2478	47	91534-SE0-000	2633	16
90467-09166	3241	59	90904-67036	3077	26	91545-SE0-0030-W1	2615	48
90467-09212	3361	27	90904-67037	3076	26	91558-SE3-003	3328	62
90467-10161	2851	43	90913-0074	3305	34	91560-SLJ-J01	3353	41
90467-10161A	2851	43	90914-0007	3306	55	91560-S84A-A01	3004	44
90467-10183	3308	56	90914-0055	3359	60	91561-S84-A00-M1	2897	58
90467-10188	3095	45	90914-0059	3307	55	91561-S84-A01-M1	3055	17
90467-11100	3301	26	91500-SM4-999A	3090	107	91561-SJD-003	3275	54
90467-13008	2370	17	91501-S1K-0030	3119	34	91566-SP0-003	3364	40
90467-17004	2578	18	91501-SEA-0030	see 3267	26	91568-SR2-003	2844	28
90467-A0002	3297	40	91501-SG0-003	2632	16	91619-SA5-003	2503	101
90467-A0003	2913	33	91501-SM4-003	2598	19	91626-SH3-003	3072	103
90467-A0005	3228	45	91501-SNA-0030	3267	26	91635-SM4-003	2608	18
90467-A0008	3261	40	91501-SO4-003	2886	49	93904-46320	3090	107
90468-04030	2440	61	91501-STK0030	3119	34	9415191	2520	82
90505-SM4-003	2613	57	91501-SWA-003	3374	33	9417855	2803	82
90505-SX0-003	3194	52	91501-TA0-0000	3305	34	9422202	2665	77
90602-S7S-0030	3176	20	91501-TR0-003	3372	56	9423101	2895	106
90602-SX0-0030	3173	20	91502-S84-A11	2971	31	9428738	2345	77
90603-S7S-0030	3177	20	91502-S9A-003	3349	26	9431995	2743	78
90603-SX0-0030	3174	20	91502-SM4-0000	2548	57	9432137	2321	67
90651-689-0030	2378	17	91502-SP0-003	2884	58	9432552	2537	71
90651-689-9000	2378	17	91503-S0K-A01	3229	53	9433155	2255	85
90652-SB2-023	3080	62	91503-S7A-003	2883	74	9433159	2708	85
90657-SA5-003	2366	56	91503-SP0-0030	2609	57	943355	2271	82
90657-SA6-0030	2716	58	91503-SZ3-003	2883	49	9436165	2482	81
90657-SB0-0030	3019	51	91503-SZ5-003	2898	49	9436175	2121	66



## OEM/W&E CROSS REFERENCE GUIDE

OEM #	W&E #	PG. #	OEM #	W&E #	PG.#	OEM #	W&E #	PG. #
9437552	2563	66	BF-82-50-233	2624	57	F58B-16237A02-AB	2785	35
9437938	2122	66	BP4K-58-762	3341	31	F6DZ-5402316-AA	2935	19
9439719	3288	69	C5ZZ-6542413-B	387	63	F7DB-5402316-AA	2935	19
9442361	3217	69	D1AB-6542413-AB	387	63	FB01-56-964	2491	57
94530585	3270	44	D20B-6522841A	2327	109	G032-68-865A	3365	40
94841130	2381	100	D3AB-138093-AC	1025	96	H001-50-841	2374	100
94841226	2496	25	D3AZ-13410-D	3213	130	J3081054	2752	33
94854203	3063	103	D3HB-13A093-AB	2118	96	KA01500Z1	2266	72
95005064	2375	41	D40Z-13410E	3029	129	LA01-56-135	2496	25
95008221	2851	43	D40ZZ-13410-E	3213	130	MB029-111	2381	100
95900-04036	2236	100	D4LY-13410-A	3034	129	MB-098145	2277	100
95900-08025	2611	98	D4SZ-13410-E	3213	130	MB-106212	2502	101
96057846	2991	51	D4ZZ-13031A	2178	95	MR-200300	3109	52
9616231	2222	83	D5AB-7120818-A	2110	14	MS-480001	2236	100
9617200	2127	14	D5UB13B-160-AA	2383	95	MS-480002	2248	98
96185-6006	3092	103	D5UB2220232AA	358	14	MU000319	2889	49
9662950	378	63	D5UZ-13031-A	2179	95	N 143893	2200	60
96706-B0700	2236	100	D7AZ-134112-A	3029	129	N304-13-356A	2716	58
96706-H2500	2539	101	D7FZ-13412-A	3029	129	N606624-S191	2784	17
96706-H940	2502	101	D8BB-13A093AB	2144	96	N606676-S2	5963	89
96706-P0105	2503	101	D9AZ-54234A46-AA	2954	65	N606677-S36	5952	89
96706-U0100	2277	100	D9BB-5402316-AA	2445	100	N621901-S36	5975	91
96706-W100	2494	101	D9OZ-6522841A	2327	109	N621903	5965	91
9685057	2105	41	D9ZZ-6643030-AA	3161	112	N621907-S55	5983	91
96FG16K262AA	2942	59	E0SZ-154A442B	3032	129	N621940	5908	91
9711304	2273	62	E1EB-13A093AA	2235	97	N623331-S2	5989	86
9716926	2282	109	E1TB-13A093AA	2235	97	N623332	5920	86
9721917	2281	109	E25-13B1600AA	840	95	N623333-S100	5902	86
9731301	353	63	E3DB-13A093AF	2268	97	N623333-S2	5902	86
979878-6	3298	69	E3DB-14A163CA	2216	46	N800369-S2	2446	106
9808241	371	63	E3DZ-13032A	2268	97	N800503S	2213	99
9818648	1205	41	E3DZ-13032C	2268	97	N800744S	5945	92
9822198	2283	109	E3SB-6342413AB	2298	64	N801192S36	5961	92
9854717	373	63	E7ZB6120908AC	2419	16	N801603-S2	2789	74
9883583	1205	41	E8PZ-13411A	3195	130	N801925S	2364	35
9895598	379	63	E8PZ-13411B	3196	130	N802224-S	2900	38
9926-40-658	2492	35	E8PZ-13411C	3197	130	N802376-S	3021	102
9926-50-625	2366	56	E8PZ-13411D	3198	130	N802538-S301	2751	85
9926-50-635	2619	57	E8UZ1522840	2943	111	N802734-S	3208	34
9927-40-822	2962	43	E9DB-13A093-A	2535	97	N802781S	2388	46
9927-40-825	2375	41	E9DB-13N020-AA	2534	98	N802900	2364	35
9928-90-753	use#2497	118	E9DB-14A-163CA	3066	117	N802900S	2561	35
9928-91-053(-353)	2497	118	E9DZ-13032-A	2535	97	N803043S	2266	72
9991-00-412	2236	100	E9DZ-13N129-A	2534	98	N803138-S	3217	69
9991-00-503	2339	100	E9VB5420884AA	2421	14,16	N803362	2398	46
B033-68-805	2502	101	F24B-13A093-BA	2535	97	N803387-S300	3005	39
B37F-50B11	3225	25	F2B-13N020-AA	2534	98	N803421S	2458	47
B4555-6135	3225	25	F37-13N129A	2700	98	N803494S	2405	56
BC1D-56-145	3226	59	F57Z-16241-AB	3325	24	N803678-S	3097	40



## OEM/W&E CROSS REFERENCE GUIDE

OEM #	W&E	PG. #	OEM #	W&E	PG.#	OEM #	W&E #	PG. #	
N803709		3212	53	N90100001	5922	91	W709629-S300	3130	21
N803749-S32B		2676	61	N989022	2367	37	W709767-S300	3325	24
N803862S	2485		72	N98905101	2105	41	W709883-S300	2993	34
N803933-S101	2749		68	W503925-S36	3054	89	W710441-S	3111	75
N803934S	2420		47	W504260	2781	79	W710250-S300	3369	55
N803946S	2415		56	W505416	3319	89	W710921-S900	3257	76
N804193-S100	2728		66	W505435	3320	90	W711687-S300	3284	40
N804344S	2508		62	W525170-S417	2890	67	W712196-S300	3215	53
N804349S	2459		37	W525172-S417	2891	67	W712665-S300	3326	55
N804379S	2356		37	W610713-S300	3245	54	W712991-S300	2640	72
N804472-S	use 2485		72	W700158-S300	2683	101	W713297-S300	3230	45
N804523-S	3217		69	W700505-S300	2681	101	W713331-S300	3273	54
N804570S	2460		56	W700548-S300	2679	27	W713610-S300	3245	54
N804583S	2355		72	W700671-S300	2678	33	W714040-S300	3214	53
N804614S	2420		47	W701054-S300	2420	47	W714415-S300	3260	54
N804675S	2653		72	W701380SSW	2680	38	XL34-17E971-AA	2987	51
N804765-S	2866		102	W701430S300	2677	35	XL3Z-17E971-AA	2987	51
N804837S	2882		58	W701649-S	2936	19			
N804851-S10	2852		68	W7016505	2935	19			
N804863S	2264		72	W701855-S300	3006	39			
N805026S	2718		58	W703069-S300	2947	102			
N805155S	2760		35	W704340-S300	2388	46			
N805350S	2507		62	W704342-S300	2485	72			
N805592-S100	2480		68	W704643	2844	28			
N805612S	2455		35	W704740S300	2756	101			
N805759-S100	2688	68,71		W704881-S300	2936	19			
N805940S	2422	116		W704958-S300	3182	52			
N806088-S58	3101	75		W705002-S300	2801	33			
N806113-S	3064	39		W705436-S300	2902	49			
N806334-S	3020	102		W705550-S300	3022	102			
N806624-S19	2784	17		W705581-S300	2413	46			
N806830-S100	2630	68		W705589-S300	2140	36			
N807389-S	2550	47		W705848-S300	2460	56			
N807438-S	2844	28		W706092-S300	3274	60			
N807572-S	3084	107		W706264-S300	2977	59			
N807620-S100	3190	69		W706350-S300	2415	56			
N807706-S	2850	101		W706494-S300	3112	59			
N807721-S	2644	38		W706713-S300	3013	59			
N807872-S32B	2780	17		W707484-S900	3050	75			
N807994-S	2756	101		W707889-S300	2992	39			
N808426-S100	2858	68		W708035-S300	3131	21			
N808592-S100	3110	75		W708045-S300	3130	21			
N808842-S	2801	33		W708088-S300	3014	29			
N811040-S	3205	31		W708325-S300	2682	58			
N811169-S	3022	102		W708530-S300	3078	51			
N811283-S	3113	59		W708771-S300	3370	16			
N811772-S	2810	108		W709154-S300	3098	40			
N811849-S300	2937	19		W709176-S300	2887	49			
N900-845-01	3219	69		W709346-S300	2643	38			

**WEE PAK RAK #1 PARTS LISTING BY PANEL- NUMERICAL ORDER**

<u>GREEN PANEL</u>	<u>BLACK PANEL</u>	<u>RED PANEL</u>	<u>BLUE PANEL</u>
99-146	99-817	99-1225	99-2547
99-147	99-818	99-1262	99-2548
99-150	99-819	99-1651	99-2549
99-156	99-822	99-1652	99-2550
99-161	99-826	99-1653	99-2609
99-341	99-837	99-1659	99-2615
99-345	99-846	99-2104	99-2618
99-349	99-858	99-2105	99-2623
99-351	99-860	99-2107	99-2643
99-353	99-875	99-2108	99-2644
99-373	99-878	99-2117	99-2653
99-378	99-879	99-2131	99-2656
99-385	99-887	99-2140	99-2687
99-387	99-910	99-2165	99-2688
99-389	99-911	99-2193	99-2758
99-537	99-915	99-2203	99-2884
99-598	99-916	99-2204	99-2885
99-599	99-917	99-2208	99-2886
99-625	99-921	99-2216	99-2889
99-634	99-922	99-2219	99-2902
99-635	99-940	99-2223	99-2958
99-637	99-942	99-2224	99-2959
99-640	99-943	99-2230	99-2966
99-656	99-945	99-2264	99-2992
99-672	99-951	99-2265	99-3040
99-675	99-963	99-2266	99-3063
99-682	99-965	99-2267	99-3109
99-728	99-966	99-2322	99-5901
99-732	99-972	99-2354	99-5902
99-740	99-1011	99-2413	99-5903
99-777	99-1205	99-2414	99-5905
99-797	99-1212	99-2423	99-5906
99-798	99-1213	99-2439	99-5920
99-799	99-1223	99-2480	99-5921
99-811	99-1224	99-2485	99-5922
99-815	99-2245	99-2528	99-5923



**WEE PAK RAK #2 PARTS LISTING BY PANEL- NUMERICAL ORDER**

<u>GREEN PANEL</u>	<u>BLACK PANEL</u>	<u>RED PANEL</u>	<u>BLUE PANEL</u>
99-636	99-2290	99-2420	99-2613
99-674	99-2296	99-2425	99-2614
99-920	99-2297	99-2449	99-2628
99-923	99-2320	99-2453	99-2629
99-928	99-2324	99-2455	99-2641
99-971	99-2338	99-2458	99-2652
99-1206	99-2339	99-2460	99-2699
99-1210	99-2345	99-2461	99-2727
99-2147	99-2347	99-2462	99-2739
99-2148	99-2351	99-2465	99-2757
99-2164	99-2356	99-2466	99-2759
99-2183	99-2357	99-2467	99-2844
99-2207	99-2361	99-2468	99-2845
99-2222	99-2363	99-2473	99-2883
99-2226	99-2364	99-2475	99-2887
99-2227	99-2365	99-2477	99-2898
99-2229	99-2366	99-2490	99-2913
99-2236	99-2367	99-2491	99-2927
99-2244	99-2369	99-2492	99-2931
99-2248	99-2370	99-2493	99-2933
99-2255	99-2373	99-2494	99-2953
99-2256	99-2374	99-2503	99-2973
99-2259	99-2375	99-2505	99-3006
99-2270	99-2379	99-2506	99-3075
99-2273	99-2382	99-2507	99-3076
99-2274	99-2387	99-2508	99-3077
99-2277	99-2388	99-2509	99-3078
99-2278	99-2398	99-2510	99-3093
99-2279	99-2399	99-2511	99-3146
99-2281	99-2407	99-2512	99-3171
99-2282	99-2408	99-2522	99-5904
99-2283	99-2415	99-2523	99-5914
99-2284	99-2416	99-2526	99-5915
99-2286	99-2417	99-2529	99-5916
99-2289	99-2418	99-2551	99-5924
99-5946	99-2974	99-2599	99-5925



## PARTS LISTING-MINI CHARTS

### PARTS LISTING-W & E MINI CHARTS

<u>MC-1</u>	<u>MC-2</u>	<u>MC-3</u>	<u>MC-4</u>	<u>MC-5</u>
1225	2361	146	915	811
2140	2366	150	916	965
2204	2398	440	942	966
2230	2399	441	943	1220
2347	2415	818	4201	2121
2356	2420	2216	4202	2122
2364	2460	2223	4203	2123
2379	2491	2264	5901	2138
2407	2548	2265	5902	2139
2414	2550	2266	5903	2162
2418	2551	2267	5904	2193
2459	2599	2270	5906	2203
2461	2609	2385	5908	2222
2493	2613	2386	5909	2226
2512	2615	2388	5910	2255
2523	2686	2439	5911	2256
2618	2739	2453	5920	2322
2628	2758	2485	5921	2340
2629	2883	2494	5922	2345
2643	2884	2496	5923	2354
2644	2885	2497	5924	2409
2652	2886	2641	5931	2423
2656	2887	2653	5938	2448
2687	2889	2748	5940	2452
2844	2898	2771	5941	2480
2913	2902	2811	5947	2622
2933	2931	2812	5948	2630
2966	2958	2901	5952	2634
2972	2959	2953	5955	2688
2973	3040	3063	5962	2777
2992	3078	3093	5963	2778
3076	3109	3146	5965	2921





## FAX ORDER FORM (W&E DISTRIBUTORS ) FAX # (973) 824-7382

**BILL TO:** \_\_\_\_\_ **SHIP TO:** \_\_\_\_\_

**NAME:** \_\_\_\_\_

**ADDRESS** \_\_\_\_\_

\_\_\_\_\_

\_\_\_\_\_

**PHONE NUMBER:** \_\_\_\_\_

**FAX NUMBER:** \_\_\_\_\_

**PURCHASE ORDER #:** \_\_\_\_\_

QTY.	W&E #	QTY.	W&E #	QTY.	W&E #





# SALES AIDS

## W & E MINI CHARTS

11" X 17" WALL CHARTS CONTAINING

32 POPULAR W & E ITEMS PER CHART (FOR PARTS LISTING SEE PG.184)

LISTED BY PRODUCT CATEGORY

IDEAL FOR QUICK REFERENCE ON ESSENTIAL BODY SHOP FASTENERS

*UPDATED REGULARLY*

*TO INCLUDE FAST SELLING NEW ITEMS*



### AUTO BODY FASTENERS



**MC-1**

PLASTIC CHRISTMAS TREE, WEATHERSTRIP & HOOD CLIPS

**MC-2**

PLASTIC SCREW RIVETS AND PUSH TYPE RIVETS

**MC-3**

MOULDING BOLTS, TERMINALS, GROMMETS, MISC. RETAINERS

**MC-4**

METRIC & STANDARD BOLTS, NUTS, SPEED NUTS, FLANGE NUTS

**MC-5**

SPECIAL SCREWS, CLIP NUTS, RIVETS, SHIMS & HOG RINGS

EACH UNIT PKG.-1

**WECD**



## 2013-2014 CD CATALOG

THE COMPLETE 2013-2014 VERSION OF THE W&E CATALOG IS AVAILABLE ON CD ROM. BROWSE BY PAGE OR USE OUR LINK FROM THE TABLE OF CONTENTS OR PRODUCT INDEX TO ACCESS SPECIFIC PART NUMBERS. SEARCH BY DESCRIPTION OR TYPE OF PART IN PLAIN ENGLISH! FOR ADDITIONAL INFORMATION OR WITH ANY QUESTIONS PLEASE CONTACT US OR YOUR W&E DISTRIBUTOR.

UNIT PKG.-1

**BL-150**

**BIN LABELS**

(REVISED-JAN. 2011)



EACH SET CONSISTS OF ONE LABEL EACH OF 150 POPULAR W&E AUTOBODY CLIPS AND FASTENERS- PEEL OFF TYPE LABEL INCLUDES: PART #, DESCRIPTION AND PICTURE OF ITEM

UNIT PKG.-1 SET

# SALES AIDS

## DISP-1



**THE W&E DISPLAY CASE - OUR MOST POPULAR AND PROVEN SALES TOOL! SET OF SIX PANELS CONTAINING SAMPLES OF VIRTUALLY EVERY PART IN THE W&E CATALOG. PARTS ARE ATTRACTIVELY DISPLAYED ON METAL PANELS AND MOUNTED IN A DURABLE CARRY CASE.**

UNIT PKG.-1

## DISP-4

### THE W&E PRINTS PORTFOLIO

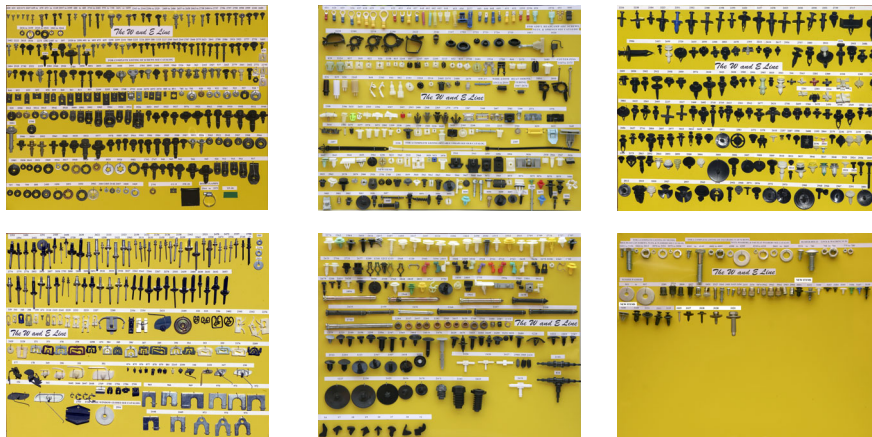

***UPDATED REGULARLY WITH NEW PARTS-INCLUDES 16" X 20" COLOR PHOTOGRAPHS SHOT FROM NEW VERSION OF DISP-1***

**W&E PRINTS PORTFOLIO-A SET OF SIX COLOR GLOSSY PHOTOGRAPHS SHOWING VIRTUALLY EVERY PART IN THE W&E CATALOG IN ACTUAL SIZE. MOUNTED IN AN ATTRACTIVE AND DURABLE PORTFOLIO CASE.**

UNIT PKG.-1 SET



**“YOU CAN’T DO BUSINESS FROM AN EMPTY WAGON!”**

**[WWW.WESALES.COM](http://WWW.WESALES.COM)**

**YOUR AUTOMOTIVE HARDWARE CONNECTION  
FOR OVER 75 YEARS**